

Wash Select II Operations Manual

With WashPay Integration



Unitec
www.StartwithUnitec.com



WASH SELECT II WITH WASHPAY INTEGRATION

OPERATIONS MANUAL

SOFTWARE VERSION 6.10

This manual provides comprehensive operational procedures for the Wash Select II. In this manual, we will discuss the setup, operation and maintenance of the Wash Select II.

If further assistance is needed, please contact the distributor from which the product was purchased.

When calling for assistance, you must have the following information available:

Wash Select II Serial Number: _____

Distributor Name: _____

COPYRIGHT

© 2012 Unitec, Incorporated. All rights reserved. No part of this book, including text, screen examples, diagrams, or icons, may be reproduced or transmitted in any form, by any means (electronic, photocopying, recording, or otherwise) without prior written permission of Unitec, Incorporated.

TRADEMARKS

Wash Select II, WashPay, VIP Wash Pass, Customized VIP Wash Pass, VIP Wash Coupons, Unitec, and the Unitec Logo are trademarks, service marks, or registered trademarks of Unitec, Incorporated.

GiveX is the registered trademark of GiveX Incorporated.

CoinCo is the registered trademark of Coin Acceptors, Inc.

All other products, services, and company names are trademarks or registered trademarks of their respective owners.

Document Revision History		
Software Version	Release Date	Changes Made
6.10	12/2012	Added support to charge tax on credit sakes through WashPay system, bug fixes
6.02	3/2012	Added Canadian support, added support for fundraisers, monetary-based fleet accounts in WashPay, added support for upgrades for product-based accounts in Washpay, bug fixes
6.01	9/2011	Added Specials as payment method, Added RFID diagnostics, bug fixes
6.00	2/2011	Original release.

[THIS PAGE INTENTIONALLY LEFT BLANK]

Table of Contents

- 1 System Overview1**
 - 1.1 Introduction to the Wash Select II with WashPay Integration.....1
 - 1.2 Wash Select II Function Changes with WashPay Integration1
 - 1.3 Setup and Operate Modes.....2
 - 1.4 Customer Interface2
 - 1.5 Wash Select II Features3
 - 1.5.1 Standard Features3
 - 1.5.2 Optional Features.....3
- 2 Initial Setup7**
 - 2.1 Credit System8
 - 2.1.1 Obtaining a Merchant Account.....8
 - 2.1.2 Credit Mode.....8
 - 2.1.3 Print Transaction Status.....8
 - 2.1.4 Print Credit Transaction History8
 - 2.1.5 Clearing the Transaction History10
 - 2.1.6 Credit + Coupon10
 - 2.1.7 Batch Functions10
 - 2.1.8 Merchant ID.....11
 - 2.1.9 POS Auth Timeout11
 - 2.1.10 Split Tender.....11
 - 2.1.11 Credit Sales Tax.....11
 - 2.2 Wash and Option Names and Prices12
 - 2.3 Speech Menu.....12
 - 2.3.1 Playback Messages12
 - 2.3.2 Record Messages12
 - 2.3.3 Set Greeting Start Delay13
 - 2.3.4 Set Greeting Repeat Delay13
 - 2.3.5 Printing Message List.....13
 - 2.3.6 Viewing Current Message List.....13
 - 2.4 Text Messages Menu14
 - 2.5 Wash Interface Menu.....14
 - 2.5.1 Enable Relay Stacking.....14
 - 2.5.2 Enable Relay Latching14
 - 2.5.3 Configure the Wash Relay Pattern.....15
 - 2.5.4 Enable Automatic Out-Of-Service Detection16

- 2.5.5 Wash Handshaking16
- 2.5.6 Wash Fault17
- 2.5.7 OOS Timer17
- 2.5.8 Tunnel Wash Settings18
- 2.5.9 Combo Mode.....18
- 2.5.10 Edit Combo Names19
- 2.5.11 Optioning.....19
- 2.5.12 Remote Code POS4000 Support.....20
- 2.6 Customer Interface Menu21
 - 2.6.1 Customer Stacking.....22
 - 2.6.2 Forced Selection22
 - 2.6.3 Allow Upgrades23
 - 2.6.4 Enabling and Setting Automatic Selection Timer23
- 2.7 Paging Functions23
- 2.8 Cash and Tokens Menu.....24
 - 2.8.1 Country Code.....24
 - 2.8.2 Configure Coin Dispensing Mode.....24
 - 2.8.3 Configure Dispensed Coin Value25
 - 2.8.4 Disabling Cash Acceptance25
 - 2.8.5 Tokens25
- 2.9 Miscellaneous Setup Menu.....25
 - 2.9.1 Alarm Duration25
 - 2.9.2 Set System Date and Time25
 - 2.9.3 Assigning a Service Phone Number.....26
 - 2.9.4 Assigning a Site ID Number26
 - 2.9.5 Enable Receipt Printer26
 - 2.9.6 Cash Receipt.....26
- 2.10 Remote Reporting Menu.....27
- 2.11 Pass Codes and Pass Cards.....27
 - 2.11.1 Using PassCodes/Cards28
 - 2.11.2 Add Code/Card28
 - 2.11.3 View Codes/Cards29
 - 2.11.4 Print Codes/Cards.....29
 - 2.11.5 Delete Code/Card29
- 2.12 VIP Wash Coupons.....30
 - 2.12.1 CoinCo Bill Validator30
 - 2.12.2 Mars (MEI) Bill Validator30
- 2.13 POS4000 Link.....33
 - 2.13.1 Interface Mode34
 - 2.13.2 Notifications.....34

2.13.3	Set Bay Address	34
2.13.4	Convey Accounting	35
3	Daily Operations	37
3.1	Reporting Menu	37
3.1.1	Configuration Report	37
3.1.2	Accounting Report.....	37
3.2	Fleet Accounts and Coupons Menu	38
3.3	Cash Reconciliation	38
3.3.1	Removing Cash.....	38
3.3.2	Adding Cash.....	38
3.4	Diagnostics Menu	39
3.4.1	Testing Output Relays.....	39
3.4.2	Cycling Output Relays.....	39
3.4.3	Testing Inputs.....	40
3.4.4	Testing Coin and Bill Pulse Relays	40
3.4.5	Test Coin Dispenser.....	41
3.4.6	Testing the Magnetic Card Reader	41
3.4.7	Testing the Thermal Printer.....	42
3.4.8	Testing the Standard Keypad.....	43
3.4.9	Testing the Buttons	44
3.4.10	Test Exp. Memory	44
3.4.11	Test RFID (AWID)	44
3.4.12	Inapplicable Diagnostics with WashPay Integration	44
4	Component Operation & Maintenance	45
4.1	Component Locations.....	45
4.2	Software Updates	46
4.3	Bill Validator.....	47
4.3.1	Mars Bill Validator	47
4.4	Single Coin Acceptor	54
4.4.1	Replacing the Reference Coin	54
4.4.2	Adjusting the Selectivity to the Coins	54
4.4.3	Removing the Coin Acceptor.....	55
4.5	Multi-Coin Acceptor Programming and Operation.....	56
4.5.1	Programming the IDX Acceptor.....	56
4.5.2	Programming the IDX to Accept Site-Specific Tokens	58
4.5.3	Programming Token Value	59
4.5.4	Programming Dispense Value (for \$1 coin dispensing only).....	60
4.5.5	Modifying the Hopper	61
4.5.6	Program the IDX to Accept Quarters.....	65
4.5.7	Programming the IDX to Accept \$1 Coins.....	65

4.5.8	Erasing IDX Programming	65
4.5.9	The Token Bucket	65
4.5.10	Cleaning and General Maintenance	66
4.5.11	System Settings Affecting IDX Coin Acceptor Operations	66
4.6	Speech Module	66
4.6.1	Recording Messages	67
4.6.2	System Settings Affecting Speech Module Operations	69
4.7	Proximity Sensor	69
4.7.1	Normal Adjusting of Proximity Sensitivity	69
4.7.2	Adjusting Sensitivity with the 100% Range Setting	70
4.7.3	System Settings Affecting Proximity Sensor Operations	70
4.8	Coin Hopper and Assembly	71
4.8.1	Filling the Hopper	71
4.8.2	Removing the Hopper from the Wash Select II	71
4.8.3	Cleaning and General Maintenance	72
4.8.4	System Settings Affecting Coin Hopper Operations	72
4.9	Card Reader	72
4.9.1	Card Reader Related System Settings	73
4.9.2	System Settings Affecting Card Reader Operations	73
4.10	Thermal Printer Assembly	73
4.10.1	Replacing the Printer Paper	74
4.10.2	Clearing a Paper Jam	74
4.10.3	Reset and Feed Buttons	74
4.10.4	Manually Printing a Self Test	75
4.10.5	Thermal Printer Control Board	75
4.10.6	System Settings Affecting Thermal Printer	75
4.11	Fuse	76
Appendix A.	Wash Select II – WashPay Notifications	77
Appendix B.	Circuit Board Connections	79
Appendix C.	Tunnel Mode	95
Appendix D.	Wash Select II/POS4000 Canadian Addendum	97
Appendix E.	Security Alarm Option	107
Appendix F.	Citizen CD-S500 Printer Configuration Procedures	113

Index of Figures

Figure 1. Setup/Operate Toggle Switch Location	2
Figure 2. Alternate Keypad Functions.....	19
Figure 3. Blue Service Button Location.....	32
Figure 4. Wash Select II Internal Component Locations	45
Figure 5. Locating the EPROM and Reset System Memory Button	46
Figure 6. Mars Bill Validator/Stacker.....	48
Figure 7. Mars Bill Validator—Top View	48
Figure 8. Mars Bill Stacker Replacement.....	49
Figure 9. Mars Flash Code LED	50
Figure 10. Mars with Lower Housing	52
Figure 11. Mars with Lower Housing Removed.....	52
Figure 12. Mars DIP Switches	53
Figure 13. Outside/ Inside of the IDX.....	57
Figure 14. IDX Wire Harness (Green Phoenix Connector) Configurations	58
Figure 15. Hopper View - Side Screw and Internal Hopper - Cube	61
Figure 16. Hopper View - Removing the Hopper - Cube Top.....	62
Figure 17. Hopper View - Top Removed	62
Figure 18. Hopper View - Wheel Removed	63
Figure 19. Hopper View - Guide Arm Cover Removed.....	63
Figure 20. Hopper View - Removal of the Coin Guide Arm.....	64
Figure 21. Hopper View - Coin Exit Opening and Chute	64
Figure 22. Proximity Sensor Power Block.....	70
Figure 23. Outside/Inside the IDX Coin Acceptor	100
Figure 24. Shock Sensor.....	109
Figure 25. Mounted Siren.....	109
Figure 26. Door Switch.....	110
Figure 27. WS2 Alarm Wiring Diagram.....	111

Index of Tables

Table 1. Country Codes	24
Table 2. Programming Pass Codes/Cards	29
Table 3. Mars Coupon ID Codes	31
Table 4. Wash Select II-POS40000 Wiring.....	33
Table 5. POS4000 Bay Numbering.....	34
Table 6. Conveying Accounting	35
Table 7. Bill/Coin Inputs	41
Table 8. Printer Error Codes	43
Table 9. Mars Bill Validator Flash Codes.....	50
Table 10. Mars Bill Validator DIP Switches.....	53
Table 11. IDX Program Configuration.....	57
Table 12. Wash Select II Token Values.....	59
Table 13. System Settings Affecting IDX Coin Acceptor Operations	66
Table 14. System Settings Affecting Speech Module Operations	69
Table 15. System Settings Affecting Proximity Sensor Operations.....	71
Table 16. System Settings Affecting Coin Hopper Operations	72
Table 17. Card Reader Related System Settings	73
Table 18. System Settings Affecting Thermal Printer Operations	75
Table 19. Wash Select II Token Values.....	100
Table 20. Canadian IDX Program Configuration	101
Table 21. CashCode Bill Validator Diagnostic Flash Codes.....	103
Table 22. CashCode DIP Switch Settings	105
Table 23. Programming Pass Codes/Cards	108
Table 24. Wiring Guide	110

Wash Select II Menu Tree		
Version 6.01		
Reporting Menu	Diagnostics Menu	Cust Interface Menu
Print Configuration	Test Outputs	Customer Stacking
View Configuration	Cycle Outputs	Forced Selection
Print Accounting	Test Inputs	Allow Upgrades
- Detailed	Test Bills/Coins	Auto Select Timer
- Summary	Dispense Coins	Paging Functions (N/A)
View Accounting	Test Card Reader	Edit Pager #
Clear Accounting	- Check Card Type	View Pager #s
Fleet Menu (N/A)	- Check Tracks	Print Pager #s
Add Account	Test Receipt Printer	Test a Pager
Edit Account	Test Keypad	Site ID Voice #
Add to Account	Test Buttons	Print Pager Log
Delete Account	Test Modem	Cash & Tokens
View Accounts	Get Network Info	Country Code
Print 1 Account	Modem Loopback	Token Value (N/A)
Print Accounts	485/POS Loopback	Max Tokens/Customer (N/A)
View Transaction History	Test Expansion Memory	Dispense Mode
Print Transaction History	Test RFID Reader	Dispense Value
Delete All Empty	RFID loopback	Cash Mode*
Edit Profile	Debit loopback	Misc. Setup
Add Per Profile	Test RFID (AWID)	System Time (N/A)
View Profiles	Aux P4 Loopback	Service Phone #
Print Profiles	Aux J1 Loopback	Site ID
External Fleet	Wash Setup (N/A)	Receipt Printer
Erase All	Wash Prices	Cash Receipt
Credit System	Wash Names	Receipt Bar Code*
Credit Mode	Speech Menu (24 Messages)	Alarm Duration (N/A)
Remote Setup	Play Message	Remote Reporting (N/A)
Remote Dial Up	Record Message	Enable/Disable
Print Transaction Status	Greeting Delay	Set Password
Print Transaction History	Repeat Delay	Rings to Answer
Clear Transaction History	Print Message List	Set Deaf Time
Pay Fleet Acct (N/A)	View Message List	Modem/Local
Return Credit (N/A)	Text Messages (N/A)	Passcodes/cards
Credit & Coupon	Receipt Header	Add Code/Card
Open a Batch (N/A)	2nd Line of Wash	View Codes/Cards
Close a Batch (N/A)	Greeting Screen*	Print Codes/Cards
Clear A Batch (N/A)	Wash Interface Menu	Delete Code/Card
Processor Type	Relay Stacking	VIP Coupons
Auto Batching	Relay Latching	Setup Coupon
Accept Proprietary (N/A)	Relay Pattern	Set Manufacturer
POS Auth Timeout	Auto OOS Detect	Coupon Limit
Network Params	Wash Handshaking	POS4000 Link
Merchant ID (N/A)	Fault Input	Interface Mode
Split Tender (N/A)	OOS Timer	Set Bay Address
Credit Sales Tax (N/A)	Tunnel Mode	Convey Accounting
	Barrier Gate*	Use POS Names/Prices
	Combo Mode	Notifications
	Edit Combo Names	
	Optioning	
	Remote Codes	

[THIS PAGE INTENTIONALLY LEFT BLANK]

1 System Overview

1.1 Introduction to the Wash Select II with WashPay Integration

The Wash Select II is a self-serve unattended automatic car wash entry system designed specifically for the self-serve car wash market. The Wash Select II accepts various forms of payment, interacts with customers at the car wash entrance, and arms the car wash.

With WashPay integration, the Wash Select II functionality expands to easily access remote reporting via the Internet, unlimited fleet accounts, and increased marketing and promotions functionality.

1.2 Wash Select II Function Changes with WashPay Integration

When the Wash Select II interfaces with the WashPay server, a few functions are moved from setup and operation in the Wash Select II to the WashPay server. The Wash Select II will display the message “Settings are in the WashPay Server.” For further information on how to program these functions, please see the *Sierra Software Management Application Programming Manual* at www.StartwithUnitec.com. Those functions are:

- Price and names of washes and options (added services)
- Fleet account management
- Text message setup (greeting, receipt header, second line messages, and option prompt)
- Token value setup
- System time and date
- Alarm duration
- VIP wash coupon setup
- Specials scheduling
- Fundraiser setup
- Free wash scheduling

A few functions will be disabled and will display the message “this function/setting is not available when connecting to WashPay server”. Those functions are:

- Pay fleet accounts with credit cards
- Credit refunds
- Multi-unit link to other Wash Select IIs
- Use POS4000 wash prices and names

Code entry for fleet accounts will require pressing the (*) key, unless the code is 5 digits or longer. In this case, the code will automatically be accepted after 4 seconds. In cases where the Wash Select II is connected to a POS4000, codes will be verified by the POS4000 first, then the WashPay server.

1.3 Setup and Operate Modes

The Wash Select II functions in two different modes: Setup and Operate. It can be placed in either mode by using the toggle switch at the top of the CPU board which is located on the inside right wall of the Wash Select II case. While in “Setup” mode, the Wash Select II can be programmed and reports can be viewed using the main display screen or printed using the optional thermal receipt printer. When in “Operate” mode, the Wash Select II allows the customer to purchase four different wash packages using several different methods of payment.

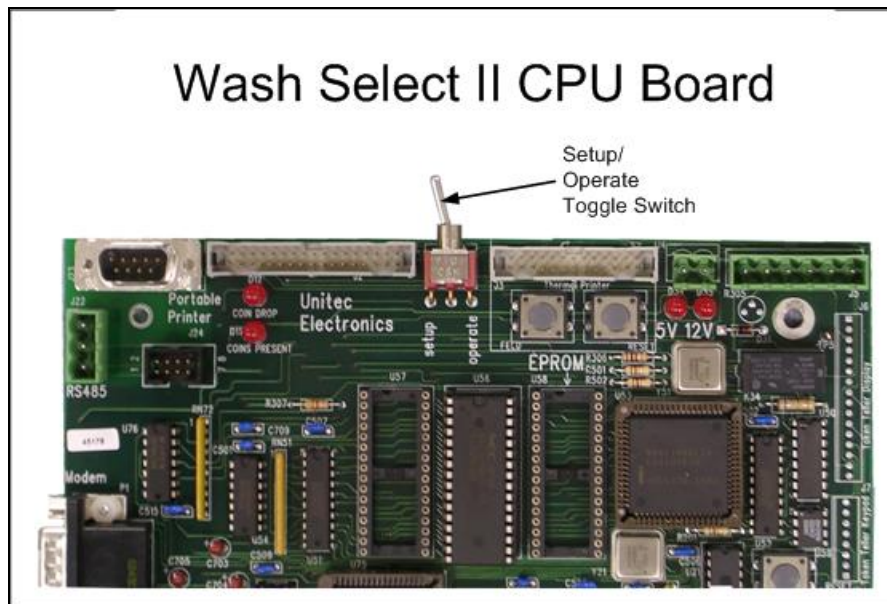

Figure 1. Setup/Operate Toggle Switch Location

1.4 Customer Interface

The Wash Select II offers many features that allow effective customer interaction, such as large-character daylight readable displays and oversized buttons. As customers approach the entry system unit, they can be greeted with a customized, pre-recorded message*. At the same time, instructions on the main display guide the customer through their choices.

The customer can either select their wash package first, and then insert payment, or insert payment and then select their wash package. Whichever way they choose, the unit will prompt them for either payment or wash package selection. When the customer has paid and

* Pre-recorded voice messages are included with the purchase of the Speech option package.

selected their wash package, they are prompted to begin the wash by either driving forward, or by pressing the start button and following the wash bay instructions.

Within these basic parameters, there are many options available for you to program to customize your individual customer's wash experience.

1.5 Wash Select II Features

The Wash Select II car wash entry system provides the features you need in order to most fully profit from your car wash.

1.5.1 Standard Features

The Wash Select II standard features provide the full range of services required by an advanced wash entry system:

- MARS Bill Validator, which allows acceptance of \$1, \$2, \$5, \$10 bills.
- 2500 coin capacity change hopper for dispensing U.S. quarters
- Acceptance of U.S. quarters via the Slug-buster II® single-coin acceptor
- One large-character daylight readable main instructional display
- Four large-character daylight readable wash selection displays
- Provides up to four wash packages
- Eight programmable wash arming relays
- Fault and warning output relays
- Pass-codes for easy entry to menus without unlocking the unit
- Padlock holes for added security in top and bottom of Wash Select II Case

1.5.2 Optional Features

In addition to standard features, the functionality of the Wash Select II can be expanded with the purchase of additional optional features:

- **Credit** – This option allows your unit to accept all major credit cards. It includes credit option software, a card reader with interface cable, and a credit transaction modem with power supply and interface cable. In addition, your site will require a dedicated phone line on site, and a Merchant account. With the purchase of this option package, you also receive the **Remote Reporting** and **Paging** options as well.
- **Multi-Coin Acceptance** – Featuring an IDX coin acceptor, the Multiple Coin Acceptance option gives your WS II the ability to accept U.S. quarters, \$1 US coins, \$1 and \$2 Canadian coins (loonies and toonies), and as many as four different bimetal tokens through a single coin slot. Detailed information for programming, operation and maintenance of this option can be found in Section 4.5 of this manual.

- **Multi-use Codes** - The multi-use codes feature, also known as "bundled wash" and similar to a fleet account, is used to sell a number of uses of a particular wash at a preset price. The customer gets a single code for these uses. The price, the number of uses, the type of wash in the package, and the feature number representing this package are preset in a "template". Once a feature (wash) number is assigned to the package, the sale of a multi-use code is similar to that of a regular code, just ringing up the feature number for the package defined in the template. (POS4000 console is required - no programming or setup is needed at the WSII.)
- **Speech Option** – This option allows the Wash Select II to give voice prompts to the customer. This option includes a speech circuit board and a speaker. The **Speech** option may be shipped with your unit, or purchased as an upgrade for an existing unit. This option features several different voice prompts including a greeting message (which requires the proximity option), a message asking the customer to make a wash selection, and a message asking the customer to insert money or codes. Detailed information for programming, operation and maintenance of this option can be found in Section 4.6 of this manual.
- **Proximity Sensor** – This option works with the **Speech** option to sense when customer vehicles approach the unit. When it senses a vehicle, the unit plays the customer greeting.
- **VIP Wash Pass Cards** – With this option you can use magnetically encoded cards for fleet sales. To use this option, your unit must also be equipped a magnetic card reader. VIP Wash Pass Cards are intended for prepaid fleet sales, and allow you to program a specific amount of washes or a set dollar amount for each account. If the account uses or dollar value becomes low, more washes can easily be added.
- **VIP Wash Coupons** –VIP Wash Coupons can be used as a great advertising tool. There are six different VIP Wash Coupons available, and you can have up to three concurrently valid at any one time. **VIP Wash Coupons** are printed in magnetic ink to inhibit fraud. Each coupon can be customized with your site name and location on the back in red ink. These coupons can be used to offer discounts or even free washes to your customers. Programming information can be found in Section 2.12 of this manual.
- **Card Reader** – This option is required to enable the acceptance of VIP Wash Pass cards and Pass cards with the **Enhanced Fleet** option, and also to accept credit cards with the **Credit** option.
- **Thermal Receipt Printer** – This option provides the ability to print reports, cash and credit receipts, and customer over payment vouchers. The **Thermal Receipt Printer** option is a 27 character high-speed thermal printer. The Wash Select II can detect printer problems and alert the operator via the warning relay output, a page, alarm status on the configuration report, or upon login for remote reporting.
- **Remote Reporting** – With WashPay integration, remote reporting is available via the Internet.
- **GiveX** – This option allows the Wash Select II to accept the proprietary GiveX gift card across multiple car wash sites using a dialup network. The **Credit** option is also required to accept GiveX cards.

- **Multi-Unit Fleet** – The Wash Select II multi-unit fleet upgrade feature enables the sharing of fleet accounts generated at a Master unit for use at any bay in your system, including the Master. This option does not require, and is not compatible with the POS4000 option.
- **POS4000** – This separate unit produced by Unitec provides the ability to sell and share codes from a C-Store.
- **External Fleet** – This option allows the use of third-party cashless card systems, such as eWash, ExpressKey, and WashCard.
- **Security Alarm** – This option adds an alarm to the WSII that monitors the door for unauthorized entry, and a shock sensor for detecting attempted vandalism. When triggered, a siren will sound from 1-60 minutes (to configure, see Section 2.9.1), a message will display and print on the POS4000 controller in the store (if equipped), and a page will be sent (if configured for paging).
- **Barrier Gate** – With the purchase of this option, the Wash Select II can be integrated with a gated system to control the flow of cars into either attended or unattended tunnel washes. Sites with multiple lanes will require the installation of the gate controller as well. For more information, see the *Unitec Gate Controller for Multi-Lane Applications Install Guide*.

[THIS PAGE INTENTIONALLY LEFT BLANK]

2 Initial Setup

The Wash Select II configuration menus provide the ability to customize your unit to interface with your site-specific options, wash equipment, and marketing plans. The following sections provide configuration procedures for each of the available menu functions.

If you are integrating the Wash Select II with the WashPay Site Management System, ensure the expansion board is installed in the upper right corner above the CPU board on the inside right wall of the WSII unit and is connected to the CPU board with a short ribbon cable. A CAT5E Ethernet cable will be connected from the expansion board to the router in the office/C-store. Then complete the following steps:

1. Place the WSII in Setup mode. Scroll to: Credit System (*) Credit Mode (*) 6 (*)
2. The Version of the installed expansion board will be displayed. If the board is not connected correctly, the error "NIC not found!" will be displayed on the LCD windows on the door. The credit mode will not save and the system will not connect to the WashPay server until this is corrected.
3. Scroll to Network Params (*)
4. You should see "Rev#: WP2.XX. Press any key." Press any key to continue. If this message is not displayed, make sure the LED light is lit on the expansion board by the Ethernet cable and make sure the ribbon cable and Ethernet cable connections are secure, then reboot the Wash Select II unit.
5. The network status will be displayed:
 - host connected: communication to the server is established (or)
 - network online: server connected, but no communication (or)
 - network down [x]: where x equals one of the following error codes:
 - 1 - No DHCP returned
 - 2 - Cannot create TCP server
 - 3 - Cannot set up UDP socket
 - 4 - Cannot find controller
 - 5 - Did not connect to TCP server
 - 6 - Did not get a device ID
 - no response: No response from the interface (If "no response", set up will exit.)
6. The parameters will be sent to the network interface. If successful, it shows "IP addresses set", otherwise "Cannot Set IP".

2.1 Credit System

The Credit system manages credit transactions. These include all major credit cards and the Mercury Gift Card. Credit system options are configured using the Credit System menu.



Note:

The Wash Select II is Cardholder Information Security Program (CISP) compliant: Being CISP compliant, Wash Select II does NOT:

- Store or print magnetic stripe data or card verification data subsequent to initial authorization of a transaction;
- Store complete credit card number or expiration date after the transaction is settled.
- Print complete credit card number or expiration date on any printouts, including output through Remote Report.

2.1.1 Obtaining a Merchant Account

You must have a Merchant Account in order to use the Credit option.

If you have not acquired a merchant account, contact Unitec at 1-800-486-4832 ext. 108 for compatible merchant account specifications to ensure that your merchant account provider will operate with Unitec equipment.

2.1.2 Credit Mode

The Wash Select II operates in several different credit modes. The mode used with WashPay integration is Mode 6. This was already programmed during setup.

2.1.3 Print Transaction Status

Place the WSII in Setup mode. Scroll to: Credit System (*) Print Trans Stat (*)

2.1.4 Print Credit Transaction History

The WSII holds information on the 500 most recent credit transactions. The oldest transaction gets purged from the system when a new transaction is completed.

1. Place the WSII in Setup mode. Scroll to: Credit System (*) Print Trans Hist (*)
2. You will be given two options. (1 = Detailed, 2 = Condensed) Choose the option you want and then press the (*) key to enter.
3. You will be given two options. (1 = Date Range, 2 = All Records). If you want a specific date range, choose 1 and press the (*) key to enter then enter the date range. If not, press 2.

Below you will find sample of each type of report.

Detailed: Prints all available information from processed network (e.g. credit) transactions.

CREDIT TRANS HISTORY



Current Date: 02/14/2010
Current Time: 10:05AM
Transactions in history: 1

INDEX NUMBER: 0
STATUS:REG. SALE CAPTURED
ACNT#:XXXXXXXXXXXX0736
CARD: Visa
TIME:15:21 DATE:02/11/10
WASH: 4 AMOUNT:\$ 8.00
REFERENCE:011109
RESP CODE: 200 (APPROVED)

CAPTURED CREDIT SALES:
AX-AMEX 0 \$0.00
VI-VISA 1 \$8.00
MC-MASTERCARD 0 \$0.00
DS-DISCOVER 0 \$0.00
VC-SHEETZ Z 0 \$0.00
DC-DINERS/CART 0 \$0.00
JC-JCB 0 \$0.00
DB-DEBIT 0 \$0.00
VF-VISA FLEET 0 \$0.00
MF-MC FLEET 0 \$0.00
WF-WRIGHT EXP 0 \$0.00
PL-SHEETZ ADV 0 \$0.00
YF-VOYAGER 0 \$0.00
FF-FLEET ONE 0 \$0.00
FC-FLEETCOR 0 \$0.00
OTHER 0 \$0.00

Condensed: Prints a summary of information from processed network (e.g. credit) transactions.

CREDIT TRANS HISTORY

Current Date: 10/20/2010
Current Time: 10:05AM
Transactions in history:2

TYPE & ACCOUNT# AMOUNT DATE
AMEX 9012 \$5.00 1020
VISA 0736 \$6.00 1019

CAPTURED CREDIT SALES:
AX-AMEX 1 \$5.00
VI-VISA 1 \$6.00
MC-MASTERCARD 0 \$0.00
DS-DISCOVER 0 \$0.00
VC-SHEETZ Z 0 \$0.00
DC-DINERS/CART 0 \$0.00
JC-JCB 0 \$0.00

DB-DEBIT	0	\$0.00
VF-VISA FLEET	0	\$0.00
MF-MC FLEET	0	\$0.00
WF-WRIGHT EXP	0	\$0.00
PL-SHEETZ ADV	0	\$0.00
YF-VOYAGER	0	\$0.00
FF-FLEET ONE	0	\$0.00
FC-FLEETCOR	0	\$0.00
OTHER	0	\$0.00



Note: The credit cards types in the Captured Credit Sale section shown in the samples are for Credit Mode 5. In other Credit Modes, only Amex, Visa, MC, Discover and Other are shown.

2.1.5 Clearing the Transaction History

This function will clear all information in the “Credit Transaction History”. If you periodically print a “Credit Transaction” report for record keeping, you may want to clear the information after you receive a successful print out.

Follow the steps below to clear your “Credit Transaction History”:

1. Place the WSII in Setup mode. Scroll to: Credit System (*) Clear Trans Hist (*)
2. You will be asked “Clear Credit History?” Press the (1) key for YES or the (3) key for NO, at this point the display will read “History Cleared”.

2.1.6 Credit + Coupon

The Credit + Coupon feature allows a coupon fleet account customer to use a credit card to upgrade their wash package using a credit card prior to selecting a wash package. This setting is enabled by default. Note that this setting does not affect the use of VIP coupons in any way.

Follow the steps below to enable the “Credit + Coupon” feature.

1. Place the WSII in Setup mode. Scroll to: Credit System (*) Credit & Coupon (*)
2. You will be asked “Coupon & Credit?” Press the (1) key for YES or the (3) key for NO.

2.1.7 Batch Functions

All batching functions are not applicable when the Wash Select II is integrated with the WashPay server.

2.1.8 Merchant ID

The Merchant ID will be entered during setup of the WashPay site server. For further instructions, please see the *Sierra Management Application Programming Manual* at www.StartwithUnitec.com.

2.1.9 POS Auth Timeout

This setting allows you to decide how much time to allow the POS authorization device to give the final authorization needed to arm the wash in a POS auth transaction. Under normal operating conditions, the default setting should be used. Only change it if absolutely necessary.

Follow the steps below to configure the POS auth timeout.

1. Place the WSII in Setup mode. Scroll to: Credit System (*)
2. Scroll through this sub-menu, until the "POS Auth Timeout" option is displayed. Press the (*) key to enter.
3. Enter any number that falls within the displayed range, and then press the (*) key.

2.1.10 Split Tender

If enabled, Split Tender allows an option to be purchased using a credit card or GiveX card, even if the wash is paid using another payment method, as long as the amount to be charged is \$1.00 or more. For a split tender to be allowed, the customer has to make the selection of the wash (or enter the wash code) and select an option before swiping card. Split tender also allows code transactions to be upgraded with an option by using a credit card, if the option sells for \$1.00 or more.

The customer may use a GiveX card, even if the account balance does not cover the purchase amount. Once the GiveX account is depleted, the Wash Select II will prompt for the amount owed. The customer may then use cash or another credit card to pay the balance. If the customer decides not to pay the balance and cancels the transaction, the amount charged to the GiveX card will be reversed and credited back to the GiveX account.

1. Place the WSII in Setup mode. Scroll to: Credit System (*) Split Tender (*)
2. Select 1 to Enable or 2 to Disable and press the (*) key to enter.

2.1.11 Credit Sales Tax

Some regions of the country require that sales tax be added to credit transactions. If your state requires this tax, you may configure the WSII to add tax to the wash transaction. Any portion of the sale purchased with a credit card will automatically have tax added when this feature is enabled.

1. Place the WSII in Setup mode. Scroll to: Credit System (*) Credit Sales Tax (*)
2. The unit will ask if you want to enable credit sales tax. Select 1 for Yes or 2 to Disable and press the (*) key to enter.

3. Enter the amount of tax in percent form (0.00%) and press the (*) key to enter.

2.2 Wash and Option Names and Prices

The wash names and prices and added services (options) are programmed in the WashPay server. For further instructions, see the *Sierra Management Application Programming Manual* at www.StartwithUnitec.com

2.3 Speech Menu

The functions in this menu will allow you to configure and test the optional speech module card. This card attaches to the middle of the CPU board of the Wash Select II.

2.3.1 Playback Messages

This function will allow you to playback each of the 24 speech messages. When you enter the play message function, choose the message you wish to hear. The following steps will walk you through the “Playback Messages” function.

4. Place the WSII in Setup mode. Scroll to: Speech (*) Play Message (*)
5. Enter the number of the message you wish to hear or press (0) to hear all messages.

Once you have entered the message number, the display will show you the message name, message number and the length of the message played.

EXAMPLE:

GREETING MESSAGE

PLAYING: 1 10.25S

The first line shows the message name. The second line shows that message number 1 is playing and that it is 10.25 seconds long. For more information regarding messages, refer to the “Speech Message Script” in Section 3.6.

2.3.2 Record Messages

Using this function will allow you to record a speech message. This function requires a microphone. Instructions and tips for recording speech messages are found in Section 3.6 of this manual.

1. Plug the microphone into the top of the CPU board.
2. Place the WSII in Setup mode. Scroll to: Speech (*) Record Message (*)
3. Enter the number of the message you wish to record (1-24). Press (*).
4. Record the message.

2.3.3 Set Greeting Start Delay

This function is used to set the amount of time that the Wash Select II will wait to activate the greeting message after the Proximity sensor detects the presence of a vehicle. This delay is usually set to give the customer enough time to roll down the window once they have stopped in front of the Wash Select II. This time may be set between 0 and 10 seconds. The system default setting is three seconds. Follow the steps below to set the greeting start delay time.

1. Place the WSII in Setup mode. Scroll to: Speech (*) Greeting Delay (*)
2. Enter the length of time you wish the Wash Select II to wait before activating the greeting message (0-10 seconds), and then press the (*) key.

2.3.4 Set Greeting Repeat Delay

Using this feature, you will set the greeting message repeat delay. This is the amount of time that the Wash Select II will wait before repeating the message if the customer has not responded by selecting a wash, entering cash or swiping a credit card. The greeting repeat delay may be set between 0 and 60 seconds. This default setting is 20 seconds. Follow the steps below to set the greeting repeat delay time.

3. Place the WSII in Setup mode. Scroll to: Speech (*) Repeat Delay (*)
4. Enter the amount of time you wish the Wash Select II to wait before repeating the message, and then press the (*) key.

2.3.5 Printing Message List

Using this command, you can print a list of speech messages. The list will show the message number, message name and the length of the message. To print the message list, follow the steps below.

1. Place the WSII in Setup mode. Scroll to: Speech (*) Print Msg List (*)
2. The message list will begin to print.

2.3.6 Viewing Current Message List

If you do not have the optional thermal printer, you may view the message list using this function. The list will show the message number, name and the length of the message. Follow the steps below to view the current message list.

1. Place the WSII in Setup mode. Scroll to: Speech (*) Play Message (*) View Msg List (*)
2. You will need to use the (3) button to scroll forward to view the next message and the (1) key to return to the previous one.

2.4 Text Messages Menu

Text messages are different messages that appear within the Wash Select II system such as receipt messages and the second line of the wash display. Text messages need to be programmed into the WashPay server. For further instructions, please see the *Sierra Management Application Programming Manual* at www.startwithunitec.com.

2.5 Wash Interface Menu

Most car wash manufacturers support the Wash Select II default settings. However, if anything must be changed in order to interface with your car wash, it may be done within the Wash Interface menu.

2.5.1 Enable Relay Stacking

Relay stacking is the ability for the Wash Select II to hold all arming signals while the wash is in use. Most car wash systems will work with (or prefer to work with) Relay Stacking enabled. Some systems that have bay entry signs require the Relay Stacking to be disabled.

ENABLED – No arming signals will be sent to the wash if the wash is “In Use” (See Wash Handshaking). If a purchase is “In Use” and another wash is purchased, the Wash Select II will hold the new wash until the previous wash has completed its cycle.

DISABLED – The Wash Select II will send any wash arming signal immediately, even if there is a wash in progress.

To configure “Relay Stacking”, follow the steps below.

1. Using the toggle switch at the top of the CPU board, place the Wash Select II in setup mode by moving the switch toward the back of the Wash Select II case. (The CPU board is located on the inside right wall of the Wash Select II case.)
2. Using the (3) key to scroll forward and the (1) key to scroll back, scroll through the main menu until the “Wash Interface” option is displayed. Press the (*) key to enter. (This should be the first option displayed.)
3. Scroll through this menu until the “Relay Stacking” option is displayed, and then press the (*) key to enter.
4. Press the (1) key for “YES” (enabled) or the (3) key for “NO” (disabled).

Default setting = Yes/Enabled

2.5.2 Enable Relay Latching

“Relay Latching” describes the type of relay output for the wash arming signals. Most car washes prefer the signals to be set as “Pulsed/No”.

Yes/Latched – Relays are turned on when the arming signal is sent to the car wash. These relays stay on until the customer purchases an upgrade (provided upgrades are enabled) or the wash becomes “In Use”.

No/Pulsed – Relays are turned on for a two second pulse when the arming signal is sent to the car wash. These relays will not be re-activated unless an upgrade is purchased (provided upgrades are enabled).

Use the steps below to assist you when enabling this feature.

1. Place the WSII in Setup mode. Scroll to: Wash Interface (*) Relay Latching (*)
2. Press the (1) key for “YES” (Latched) or the (3) key for “NO” (Pulsed).

Default Setting = No/Pulsed

2.5.3 Configure the Wash Relay Pattern

The “Wash Relay” pattern allows you to decide which relays will be turned on for each wash package. The industry standard is that one relay should be turned on for each wash package. The Wash Select II provides eight wash relays, which allows the relay pattern to be re-configured if you wish to change a wash to another output relay. This is helpful if a relay were to fail. Switching the wash to another output relay avoids having to replace parts. The wash relays may be used in any combination for each wash.

The following steps will help you set the wash relay pattern.

1. Place the WSII in Setup mode. Scroll to: Wash Interface (*) Relay Pattern (*)
2. Enter the wash number of the relay pattern you would like to program, and then press the (*) key to enter.
3. Turn on the relay you wish to use for this wash. This is done by using the Wash Select II keypad to select number of the relay you would like to have on while this wash is in service.

EXAMPLE :

If you wish to turn on relays 1, 3, and 7 the pattern should be shown as follows.

12345678 relays

1 3 7

This denotes that relays 1, 3, and 7 are turned on and the remaining relays are turned off.

**Note:**

Remember when setting your wash relay pattern that wash 1 is the wash in the bottom display screen and that wash 4 is in the top display screen.

DEFAULT :

Wash 1: Relay 1 only

Wash 2: Relay 2 only

Wash 3: Relay 3 only

Wash 4: Relay 4 only

Default relay patterns will be shown on the configuration report as follows.

Wash	Relays (1-8)
Wash 4 name	4
Wash 3 name	3
Wash 2 name	2
Wash 1 name	1

2.5.4 Enable Automatic Out-Of-Service Detection

If the car wash goes down, the Wash Select II can be informed to let customers know that the wash is down. The Wash Select II supports the detection of an Out-of-Service condition on the Wash-in-Use input. This method is supported by many, but not all, car wash systems.

If the Automatic Out-Of-Service detection is enabled, and the car wash goes down, the wash's Wash-in-Use signal should do the following:

- Turn off for at least one second.
- Turn on for one second. (+/- 1/8 second tolerance)
- Turn off for one second. (+/- 1/8 second tolerance)
- Turn on for the duration of the out-of-service condition.
- Turn off when the car wash is back in service.

If the Wash Select II goes Out of Service while it contains credit in escrow, a voucher will be printed for the customer.

To enable the "Automatic Out-Of-Service detection, follow the steps below.

1. Place the WSII in Setup mode. Scroll to: Wash Interface (*) Auto OOS Detect (*)
2. Press the (1) key for "YES" or the (3) key for "NO".

Default: Enabled

2.5.5 Wash Handshaking

The Wash Select II supports two types of "Wash-In-Use" handshaking.

- Wash-In-Use: The car wash activates the wash-in-use signal for the entire time the car wash is in use. (Voltage present)
- Cycle complete: The "Wash-In-Use" is normally on (voltage present). When it is given a "wash is completed" signal (no voltage present), the car wash will deactivate the "Wash-In-Use" signal for about two seconds and it will be

reactivated. When using the “Cycle Complete” mode, “Upgrades” will be disabled and “Forced Selection” will be enabled. If your car wash supports the “Wash-In-Use” method, you should not use the “Cycle Complete”.

**Note:**

The Wash Select II supports a 24V – 120V AC or DC “Wash-In-Use signal. No internal changes need be made for either voltage.

The following steps will assist you in configuring “Wash Handshaking”

1. Place the WSII in Setup mode. Scroll to: Wash Interface (*) Wash Handshaking (*)
2. Press the (1) key for “Wash-In-Use” or the (3) key for “Cycle Complete”.

Default: Wash-In-Use

2.5.6 Wash Fault

If your car wash manufacturer does not support the Wash-in-Use signal, you can use the wash fault input to let the Wash Select II know when a downtime occurs. When enabled, you may set this feature to detect either an on or off fault signal. Enabling the “Fault Input” signal allows the wash to send a signal to the coin box if it is malfunctioning or not in service, causing the coin box to go out-of-service. Once the coin box has gone out of service, it will display the standard Out of Service message.

If the Wash Select II goes Out of Service while it contains credit in escrow, a voucher will be printed for the customer.

To enable this feature, follow the steps below.

1. Place the WSII in Setup mode. Scroll to: Wash Interface (*) Wash Fault (*)
2. Press the (1) button for “YES” or the (3) button for “NO”.
3. The following prompt comes up. You must select whether the Wash Select II should fault when a high (on) signal is detected or a low (off) signal. “On” is the default.
 - i. 1=FAULT WHEN ON
 - ii. 3=FAULT WHEN OFF
4. Next you are prompted to enter how long (in seconds) the Wash Select II should delay after it sees the signal before it goes out of service. It can be anywhere from 1 to 300 seconds, inclusive.

Default: 10 seconds

2.5.7 OOS Timer

If your car wash is using “Cycle Complete” handshaking, a feature of the Wash Select II is that it can go out of service if the wash-in-use signal remains off for too long. “Too long” is defined by the OOS timer, which has a default of 60 seconds. Your wash may require a different amount of time. If so, follow the steps below to configure.

**Note:**

This feature may require hardware changes. If after it has been enabled, you find it does not work, refer to the Wash Select II Installations Manual for wiring instructions.

1. Place the WSII in Setup mode. Scroll to: Wash Interface (*) OOS Timer (*)
2. You will be prompted to enter the Delay before OOS. This may be set anywhere between 1 – 300 seconds (5 minutes).

Default: 60 seconds

2.5.8 Tunnel Wash Settings

The WSII can be installed at tunnel washes with or without barrier gates and with or without live attendants. Each detail of your wash can be set using the Tunnel Mode, Barrier Gate, and Receipt Bar Code configurations in the Wash Interface menu.

2.5.8.1 Tunnel Mode

When the Tunnel Mode is set to “Attended,” each customer will receive a receipt to give to the attendant, who will then arm the appropriate wash. When the Tunnel Mode is set to “Unattended,” customers will not automatically receive a receipt.

1. Place the WSII in Setup mode. Scroll to: Wash Interface (*) Tunnel Mode (*)
2. Press the (1) button for “Unattended Tunnel Mode” or the (2) button for “Attended Tunnel Mode” or (0) button to disable tunnel mode (rollover washes only), and then press the (*) key.

2.5.8.2 Barrier Gate

You must have a Barrier Gate Interface Box in order to use the Barrier Gate feature.

1. Place the WSII in Setup mode. Scroll to: Wash Interface (*) Barrier Gate (*)
2. Press the (3) button to disable the Barrier Gate option, or the (1) button to enable the option.

2.5.9 Combo Mode

Combo mode is used when your car wash is equipped to wash vehicles using both the “friction” and “touchfree” methods (the names are configurable; see the next section), and you want to give your customers the ability to select between the two depending on the wash bought. For instance, the purchase of your most expensive wash type treats customers to both wash methods (i.e. a combo), while the lesser wash types give a choice between friction and touch free. A selectable wash works by sending a different relay pattern to the wash depending on the wash method selected. Follow the steps below to set the combo mode option for each wash type. After setting the combo mode, you will want to also check and perhaps reconfigure the relay patterns for each wash. See the Combo Mode Addendum (Unitec Document WS21020) for further information.

1. Place the WSII in Setup mode. Scroll to: Wash Interface (*) Combo Mode (*)

2. Press the (1) button for “YES” or the (3) button for “NO”, and then press the (*) key.
3. If you selected to enable combo mode, you will be prompted to enter which wash types (1-4) will be selectable by the customer. Enter (1) “YES” or (3) “NO” for each prompt that pops up.
4. You are next prompted to enter the default wash if no selection. Press the wash button corresponding to which wash method you want to give customers as the default should they fail to make a timely selection after having purchased the wash. (This “automatic selection” will only work if you have the Auto Select option (in Customer menu) enabled).

2.5.10 Edit Combo Names

The default names for the two wash methods of combo mode are “Softtouch” and “Touchfree”.

Refer to Figure 2 for the different characters available for each key. Press each key until the desired character displayed. Press the (#) key to accept the character and continue to the next character. When you have finished entering Wash Name, press the enter (*) key.

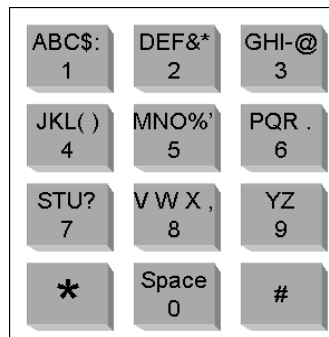

Figure 2. Alternate Keypad Functions

To change the Combo names:

1. Place the WSII in Setup mode. Scroll to: Wash Interface(*) Edit Combo Names (*)
2. Use the diagram of alternate keypad functions in Figure 2 to assist you in programming the name of your friction wash method.
3. Again using Figure 2, program the name of your touchfree wash method.

2.5.11 Optioning

The Optioning feature allows you to add options to a wash package. It appears after a wash selection is made during the normal purchase process. If enabled, any time a wash package is selected, an option screen will display. Wash upgrades are not permitted when Optioning is enabled. No wash is armed on code entry until after an option selection is made or declined and payment is added.

The Optioning feature is highly configurable and a separate menu is provided with all the associated commands. This menu is located under the existing Wash Interface menu. In addition, a new command under the Credit Menu called “Split Tender” (See Section 2.3.19) controls whether a credit card can be used to purchase an option.

To enable Optioning:

1. Place the WSII in Setup mode. Scroll to: Wash Interface (*) Optioning (*)
2. Press the (1) button for “YES” to enable or the (3) button for “NO” to disable, and then press the (*) key.

If you chose to enable Optioning, you will then need to set the Features, Option prices and names. This task is accomplished on the WashPay server. For further instruction, please see the *Sierra Management Application Programming Manual* at www.StartwithUnitec.com

2.5.12 Remote Code POS4000 Support

The Wash Select II may be configured to interface to a POS4000 in order to be activated by codes sold at one or multiple POS4000 units. In cases where it is not feasible to wire the POS4000 and WSII to each other, the Remote Code option may be used. This option allows an encrypted wash code to be sold from the POS4000, then, once this code is entered into the WSII, it is decrypted and the wash is fired.

For Remote Code functions, make sure washes and options programmed in the WashPay server are same as ones programmed in the POS4000 or the code will be declined. For example, a code sold with an option will not be accepted in a WSII with optioning disabled. Also verify the date settings on the WSII and the POS4000 involved to make sure they are accurate because the Remote Code function depends on them.

2.5.12.1 Enable and Setup Remote Code

Before starting using remote code, make sure these requirements are met: on the WSII:

- Expansion memory installed
- POS LINK is not set to POS4000 Link

To enable the Remote Code function in the WSII:

1. Place the WSII in Setup mode. Scroll to: Wash Interface (*) Remote Code (*)
2. “Use Remote Code?” will be displayed. Press (1) for yes and (3) for no. Press (*) to enter.

Once enabled, go to Parameter Setup and enter the following information:

- IDs of POS Where Codes Sold: enter the ID of the POS4000(s) where the code is sold. Up to 4 POS4000 IDs are supported. Default = 1

- Code Expiration: number of days a code is good after purchase from 1 to 60 days. Default=14
- Daily Code limit: maximum number of codes can be issued per day from 10 to 190. Default = 100
- Security Code: used to decrypt the wash code and is up to 7 digits. Using default value or simple numbers like “1234567” or “3333333” is discouraged.

Note: After completing the items, the settings are printed out. Keep printout as the same settings are entered into the POS4000(s).

Remote codes are accepted in multi-WSII with POS link. When a code is entered at a secondary unit, it will be checked with the POS4000 first then the remote code, while at the Primary it will be checked for remote code first.

2.5.12.2 Remote Code Utilities

To access the Remote Code utilities, go to the Wash Interface menu.

- Print Used Codes: Get a printout of the redemption of the codes sold on a particular day. Enter the date when the code issue date in the MMDD format (leading 0 required), then press “*”. Codes redeemed in any secondary units connected are included too.
- Clear Used Codes: To clear the code redemption history.

2.5.12.3 Changes to Code Entry on Wash Select II

When Remote Code is enabled, these features apply to all codes entered in the WSII keypad:

- DO NOT use 6 or 7 digit codes for fleet accounts when using Remote Code. The Code Length may conflict with codes sold at the Remote Code POS4000.
- Zeros in code no longer serve as the Enter key, it can appear in any position for any code.
- Fleet Account codes which have 5 digits or less will require the code to end in 0 in order for the code to be accepted.
- For codes longer than 5 digits, a 3 second pause will cause the code to be entered automatically.

2.6 Customer Interface Menu

The “Customer Interface Menu” contains functions that affect the operation of the coin box with the customer.

2.6.1 Customer Stacking

This feature allows you to enable or disable the ability for the Wash Select II to interact with a customer in front of it while the wash is in use.

ENABLED – When this feature is enabled, it allows the Wash Select II to interact with a customer at the coin box while another customer is using the wash. The Wash Select II will greet the customer, allow the purchase of a wash and if the previous customer has not completed their wash, they will be instructed to please wait until the wash is no longer in use.

DISABLED – The Wash Select II will not allow any interaction at the coin box while the wash is in use.

The steps below will help you to enable this feature.

1. Place the WSII in Setup mode. Scroll to: Cust. Interface (*) Cust. Stacking (*)
2. Press the (1) button for “YES” (Enabled) or the (3) button for “NO” (Disabled).

Default: Enabled

2.6.2 Forced Selection

The “Forced Selection” feature will force a wash selection by the customer for all cash and token purchases. This setting will not affect Credit or Fleet transaction.



Note:

If “Allow Upgrades” is disabled while “Forced Selection” is also disabled, the Wash Select II will automatically enable Forced Selection.

ENABLED – With this feature enabled, the customer must make a wash selection before a wash is activated. If a customer adds cash or tokens without selecting, the Wash Select II will instruct them to make a selection. At this point, all wash displays for which the customer has deposited enough money/tokens to purchase will begin to flash and the current credited amount will be displayed.

DISABLED – If this feature is disabled, once a customer deposits enough cash/tokens to pay for the least expensive wash that wash will be armed. For example: A customer adds \$1 bills one at a time until there is a credit of \$4, the \$4 wash would automatically be armed. However, if the customer adds enough cash/tokens to pay for a more expensive wash, that wash will be armed. The customer cannot make another selection or receive change.

Follow the steps below to enable “Forced Selection”.

1. Place the WSII in Setup mode. Scroll to: Cust. Interface (*) Forced Selection (*)
2. Press the (1) button for “YES” (Enabled) or the (3) button for “NO” (Disabled).

Default: Enabled

2.6.3 Allow Upgrades

The Allow Upgrades feature is disabled when integrated with WashPay.

2.6.4 Enabling and Setting Automatic Selection Timer

This setting is disabled by default, but if enabled it will allow the Wash Select II to make a wash selection if the customer has not done so within a specified time. This helps compensate for a customer that deposits cash, but drives into the wash without making a wash selection. For example: The auto select timer has been set to 30 seconds. Your wash prices are set at \$4, \$5, \$6 and \$7. The customer deposits a \$5 bill, and then drives into the wash without making a wash selection. After 30 seconds, the Wash Select II will automatically arm the \$5 wash.

Here are the steps to enable this feature.



Note: You may disable this feature by setting the timer to “0”.

1. Place the WSII in Setup mode. Scroll to: Cust. Interface (*) Auto Select Timer (*)
2. Enter the amount of time you wish the Wash Select II to wait before automatically arming a wash (1-120 seconds), and then press the (*) key to enter.

2.7 Paging Functions

When integrated with the WashPay server, paging functions are handled through the notifications function of the Sierra server via email or text message. Please see the *Sierra Management Application Programming Manual* under Users.

2.8 Cash and Tokens Menu

This menu contains functions that affect the acceptance and/or dispensing of cash and tokens.

2.8.1 Country Code

The country code affects the assignment of coin and bill values for each coin and bill input, as well as which coin input is used for tokens. The Wash Select II software will support these countries; however, hardware changes are required for the cash components to work for different countries.

Table 1. Country Codes

Country Code	Country
0	USA
1	Canada Mode 1 (Dispense \$.25)
2	Canada Mode 2 (Dispense \$1)
3	Australia
4	Europe (Not yet available.)

Default : USA

2.8.2 Configure Coin Dispensing Mode

The “Coin Dispensing Mode” will allow you to configure the manner in which coins are dispensed. You may use the Wash Select II as a changer (put money in and press refund), or decide if a purchase is necessary to receive change. No matter how this feature is configured, however, no money may ever be refunded if the amount has already been applied to the purchase of a wash.

DISPENSE MODE 0: (NONE)

Pressing the refund button will not give change under any circumstance.

DISPENSE MODE 1: (AFTER PURCHASE)

Pressing the refund button before a wash is purchased will not result in a refund. If you have purchased the \$4 wash and choose to upgrade the \$5 wash, but change your mind before the upgrade is complete, the Wash Select II will refund any money over the price of the \$4 wash as long as the additional money has not been applied to the purchase of a wash.

DISPENSE MODE 2: (ANYTIME)

The Wash Select II will refund any money that has not yet been applied to the purchase of a wash.

Follow these steps to configure the dispense mode:

1. Place the WSII in Setup mode. Scroll to: Cash & Tokens (*) Dispense Mode (*)
2. Enter the dispense mode of your choice (0-2), and then press the (*) key.

Default: Dispense Mode 1

2.8.3 Configure Dispensed Coin Value

This function allows you to configure the value of the coin that is dispensed (given as change). If you wish to dispense the \$1 coin, you must first modify the hopper to allow for the larger coin. The steps below will assist you with setting the “Dispensed Coin Value”.

1. Place the WSII in Setup mode. Scroll to: Cash & Tokens (*) Dispense Value (*)
2. Enter the desired value in cents format, and then press the (*) key. (Example: A value of \$.25 must be entered as 25.)

2.8.4 Disabling Cash Acceptance

You may disable the acceptance of cash at the Wash Select II unit. If you set the system to “No Cash Mode”, you will not see or print the cash-related sections of the accounting and configuration reports. To enter “No Cash Mode”:

1. Place the WSII in Setup mode. Scroll to: Cash & Tokens (*) Cash Mode (*)
2. Press (1) to enable Cash Acceptance, or (3) to disable Cash Acceptance.

2.8.5 Tokens

Token setup functions (Token Value, Max Tokens per Customer, and Dispense Value) are setup on the WashPay server. For further instructions, please refer to the *Sierra Management Application Programming Manual* at www.startwithunitec.com.

2.9 Miscellaneous Setup Menu

This menu contains features that do not fall under another specific category.

2.9.1 Alarm Duration

With the purchase of the Security Alarm option, you can set the length of time that the alarm’s siren will sound using this command. In order to do this, the date and time must be programmed into the WashPay server. For further instructions, please refer to the *Sierra Management Application Programming Manual* at www.StartwithUnitec.com.

2.9.2 Set System Date and Time

The Wash Select II will accurately keep a running date and time stamp for use in processing data and keeping accounting records. Be sure the date and time are programmed accurately. In order to do this, the date and time must be programmed into the WashPay server. For

further instructions, please refer to the *Sierra Management Application Programming Manual* at www.StartwithUnitec.com

2.9.3 Assigning a Service Phone Number

A service phone number is printed on a customer overpayment ticket (issued when change has failed to dispense). This allows the customer to call the site operator for a credit. This phone number may be entered in 7, 10, or 11-digit numeric format. Follow the steps below to program a service phone number.

1. Place the WSII in Setup mode. Scroll to: Misc Setup (*) Service Phone # (*)
2. Enter the number you wish to have printed, and then press the (*) key to enter.

2.9.4 Assigning a Site ID Number

The Site I.D. is used by the Wash Select II to identify the unit on configuration, accounting and remote reports. It is also used by the pager system to identify the site. To set a site I.D. follow the steps below.



Note: If your distributor is monitoring your site, you may wish to have them assign your site I.D.

1. Place the WSII in Setup mode. Scroll to: Misc Setup (*) Site ID (*)
2. Enter the site number, and then press the (*) key to enter.

2.9.5 Enable Receipt Printer

If you have purchased the optional “Thermal Receipt Printer“, it must be enabled for it to work. The steps below will walk you through this process.

1. Place the WSII in Setup mode. Scroll to: Misc Setup (*) Receipt Printer (*)
2. Press the (1) button for “YES” or the (2) button for “NO” or the (3) button for “AUTODETECT”.

Default: Auto

2.9.6 Cash Receipt

If your unit is equipped with the optional “Thermal Receipt Printer“, this feature will print a receipt for customers using cash, tokens, VIP wash pass coupons and the “External Fleet” option. It will also print receipts for customers purchasing upgrades with cash or forms of cash. Follow the steps below to enable cash receipts.

1. Place the WSII in Setup mode. Scroll to: Misc Setup (*) Cash Receipt (*)
2. Press the (1) key for “YES” (enabled) or (3) for “NO” (disabled).

Default: Disabled

2.9.6.1 Receipt Bar Codes

You can program a specific bar code for each wash package to be printed on each receipt. This allows the attendant to scan the bar code to activate the appropriate wash. Bar codes can be 1-99999999. To print Bar Codes:

1. Place the WSII in Setup mode. Scroll to: Misc Setup (*) Receipt Bar Codes (*)
2. Press the (1) button to enable bar codes.
3. When you enable bar codes, you will be prompted to “Enter Wash 1 Bar Code.” Key in a number (up to 8 digits in length) for this wash and press the (*) key to enter.
4. Repeat step 3 each of the remaining washes.

2.10 Remote Reporting Menu

Reporting functions are handled through the WashPay Server via the Internet. For more information, please see the *Sierra Management Application Programming Manual* at

www.StartwithUnitec.com.

2.11 Pass Codes and Pass Cards

The Pass Codes and Pass Cards discussed in this Section provide access to programming fleet accounts. They are not to be confused with the VIP Pass Cards™ or the Fleet Account Codes themselves.

This feature allows the owner/operator to gain access to the setup menu and its functions without opening the unit. Using this feature allows quick and easy management of fleet accounts, and when used along with the “Fleet Account Profiles” feature you can program a fleet account in approximately ten seconds. You may configure up to 20 codes/cards and several of them may perform the same function if you wish. This allows you to give others the ability to access specific functions without allowing them access to the inside of the unit.

Pass codes and Pass cards may be programmed to complete the following functions:

- **Alarm Activation** (Opens the Arm//Disarm menu for the Security Alarm Option.)
- **REPORTING MENU** (Allows access to the entire Reporting Menu.)
 - **Print Accounting** (Allows printing of an Accounting report without the option of clearing it.)
 - **Print & Clear Acct** (Prints an accounting report with the option to clear it.)
 - **View Accounting** (Allows you to view an Accounting Report without the option to clear it.)
 - **View & Clear** (Allows you to view an Accounting Report with the option to clear it.)
- **DIANOSTICS MENU** (Allows access to the Diagnostics Menu.)

- **Optioning Setup** (Allows you to enable/disable optioning and change optioning settings.)

2.11.1 Using PassCodes/Cards

Using PassCode/cards to help manage fleet accounts is a powerful and timesaving feature. If you want to quickly manage fleet accounts or you wish to offer promotional fleet accounts, you can program a PassCode or PassCard to help you manage it. But using PassCard and PassCodes for Fleet accounts are not their only use. Here are some ideas:

PROMOTIONAL VIP WASH PASS™ ACCOUNTS PROGRAMMED ON THE SPOT.

Set up a Fleet profile for the promotion that you wish to make, such as six of your best washes for the price of five (good stocking stuffer for Xmas). Then set up a PassCard for the “Add per Profile” function. Then keep a stack of un-programmed VIP Wash Pass™ cards with the “Add per profile” PassCard on the top. When you are ready to sell the promotion, swipe the PassCard at the Wash Select II and, then, swipe the un-programmed card. The VIP card is now activated. If you have a receipt printer, the account information will be printed for the customer.

QUICK PROGRAMMING OF VIP WASH PASS™ FLEET ACCOUNTS

Set up a PassCard for the “Add Account” function. Then keep a stack of un-programmed VIP Wash Pass™ cards with the “Add Account” PassCard on the top. When you are ready to sell the account swipe the PassCard at the Wash Select II and then configure the new account swiping the un-programmed card during the process. If you have a receipt printer, the account information will be printed for the customer.

QUICK ACCOUNTING PRINT OUT OR VIEWING

You can use one of the four accounting report functions to allow yourself or an attendant/trustee to print/view an accounting report every time the money is removed from the Wash Select II. This way you do not have to teach the attendant/trustee how to operate the unit. This is useful also if you want to have a trustee remove cash from the unit and print a report while you are on vacation.

REFUND CREDIT

You can give your attendant/trustee a PassCard that allows them to refund a credit transaction. Remember, for financial security, you cannot refund a transaction unless the customer has actually purchased a wash on their credit card. The actual sale of the card and the return credit will be logged in the credit transaction history for future reference.

2.11.2 Add Code/Card

This function allows you to add a new code or card. All code numbers must end with a zero. If the number or card you enter already exists, the Wash Select II will prompt you to enter another number. Follow the steps below to program a Pass Code or Pass Card.

1. Place the WSII in Setup mode. Scroll to: Pass Code/Card (*) Add Code/Card (*)
2. The table below will show you how to program a code and a card. The first three steps above are the same for programming each.

Table 2. Programming Pass Codes/Cards

PASS CODE	PASS CARD
<ol style="list-style-type: none"> 1. Press the (1) key for code. 2. Enter the code number, and then press the (*) key to enter. (The code must be at least four digits long and end with a zero.) 3. Using the (3) key to scroll, scroll forward until you find the menu option you are programming the code to access. 4. If you are programming a fleet account that is paid with a credit card, choose "Fleet Acct" under "Select Type" and then scroll thru and select "Pay Fleet Act." The credit card associated with the account will be charged. 	<ol style="list-style-type: none"> 1. Press the (3) key for card. 2. Insert the card into the card reader or key in the number that appears on the front of the card, and then press the (*) key to enter. (If you insert the card there is no need to press the (*) key. 3. Using the (3) key to scroll, scroll forward until you find the menu option you are programming the code to access. 4. If you are programming a fleet account that is paid with a credit card, choose "Fleet Acct" under "Select Type" and then scroll thru and select "Pay Fleet Act." The credit card associated with the account will be charged.

2.11.3 View Codes/Cards

Use this function to view all Pass Codes and Pass Cards and their configuration. The code/card numbers and all their information will be shown in the wash displays. Use the instructions below to view codes and cards.

1. Place the WSII in Setup mode. Scroll to: Pass Code/Card (*) View Codes/Cards (*)
2. Use the (3) key to scroll forward or the (1) key to scroll back to view all Pass Codes and Pass Cards.

2.11.4 Print Codes/Cards

Using this function, you can print a list of all Pass Codes and Pass Cards and the configuration information. This feature requires the optional "Thermal Receipt Printer". Follow the steps below to print a list of Pass Codes and Pass Cards.

3. Place the WSII in Setup mode. Scroll to: Pass Code/Card (*) Print Codes/Cards (*) The list will begin to print upon pressing enter.

2.11.5 Delete Code/Card

This function allows you to delete a Pass Code/Card. Follow the steps below to delete a code/card.

1. Place the WSII in Setup mode. Scroll to: Pass Code/Card (*) Delete Code/Card (*)
2. Enter the code number, and then press the (*) key or swipe the card. The "Main Display" should show that the code/card has been deleted.

2.12 VIP Wash Coupons

VIP Wash Coupons are a form of paper token for use in marketing your wash. You may distribute them just like tokens. Like cash, they are used by inserting them into the bill validator. VIP Wash Coupons must be purchased according to the manufacturer of your bill validator. You cannot use one manufacturer's coupons on another manufacturer's bill validator.

2.12.1 CoinCo Bill Validator

Six different types of VIP Wash Coupons (A-F) are available for into the Wash Select II with the CoinCo bill validator, but only three can be programmed at one time. Change will not be given when a coupon is used. A customer using a VIP Wash Coupon may cancel the transaction only if no other form of tender has been entered, but even then, the entered coupon will be lost.

Each bill validator is programmed to accept VIP Wash Coupons styles A, B, and C by default before it leaves Unitec. Coupon styles D, E, and F can be custom programmed for new units by Unitec prior to shipping, or they can be programmed after installation by purchasing a coupon programmer. If the bill validator will not accept VIP Wash Coupons, it must be reprogrammed to recognize the coupons.

The value of each coupon must be programmed in the WashPay server. If a coupon has not been programmed into the WashPay server, the bill validator will reject the coupon.

You can program the coupon value to be either a discount (e.g. the coupon gives the programmed discount to selected washes) or to be worth an entire wash (e.g. the coupon automatically credits the programmed wash).

For information on how to program coupons into the WashPay server. For further instructions, please see the *Sierra Management Application Programming Manual* at

www.startwithunitec.com .

2.12.2 Mars (MEI) Bill Validator

Up to 10 different types of VIP Wash Coupons may be programmed into the Wash Select II with the Mars (MEI) bill validator. Unitec sells 6 different styles of coupons, for your convenience. Change will not be given when a coupon is used. A customer using a VIP Wash Coupon may cancel the transaction only if no other form of tender has been entered, but even then, the entered coupon will be lost.

The value of each coupon must be programmed in the WashPay server. If a coupon has not been enabled in the WashPay server, the bill validator will not accept the coupon.

You can program the coupon value to be either a discount (e.g. the coupon gives the programmed discount to selected washes) or to be worth an entire wash (e.g. the coupon automatically credits the programmed wash).

2.12.2.1 Enabling/Disabling Mars (MEI) Coupons

This feature allows you to configure the Wash Select II to accept and credit predetermined washes or dollar amounts, or to reject specific coupons entered into the bill validator. Each coupon will be labeled M1-M6 and has a specific ID Code that must be programmed into the Wash Select. The Serial Number is printed on each of the coupons, but you must refer to the following table for the respective ID Codes.

Table 3. Mars Coupon ID Codes

Coupon Label	Serial Number	ID Code
M1	A000079	8808
M2	A000081	8840
M3	A000083	8872
M4	A000085	8920
M5	A000087	8968
M6	A000089	9000

To configure the Wash Select II to accept the coupons, perform the following procedures:

Enable Coupon

1. Press the blue service button directly on the back of the bill feed opening, below the bill stacker.

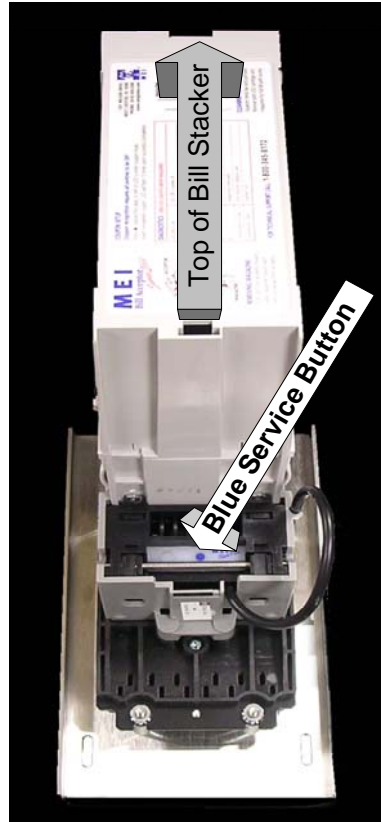

Figure 3. Blue Service Button Location

2. The Bezel Lights on the bill acceptor opening will start blinking.
3. Feed the coupon you want to be enabled.
4. The coupon will be drawn into the bill validator, and then will be ejected.
5. The flash code LED (see Section 4.3.1.3) will flash 10 times to indicate the coupon is enabled.

Disable Coupons

1. Press the blue service button directly on the back of the bill feed opening, below the bill stacker.
2. The Bezel Lights on the bill acceptor opening will start blinking.
3. Feed the coupon you want to be disabled.
4. Coupon will be drawn into the bill validator, and then will be ejected.
5. The flash code LED (see Section 4.3.1.3) will flash 3 times to indicate the coupon is disabled.

2.13 POS4000 Link

The POS4000 Link menu allows the Wash Select II to be configured to interface with a POS4000. In addition, it provides the activation of the Multi-Unit Fleet option.

Once the Wash Select II is properly configured, codes can be sold at one or more POS4000 units to be used at the Wash Select II. Configuring of these settings is also necessary for units that are equipped for authorization through the POS network. In this case, set the interface mode to '1'. If you have multiple Wash Select II units, you will also need to set the bay address for each Wash Select II.

The following instructions show how to set up the Wash Select II unit to interface to the POS4000.

1. If not already installed, with the power disconnected, install the Wash Select II communications module onto the top left hand corner of the CPU board. The board is installed with LED's on the bottom.
2. Restore power to the Wash Select II and place the unit in setup mode. If you have more than one bay, set the units up one at a time, with all un-configured units turned off.
3. Wire the POS4000 cable connections as per the following connections:

Table 4. Wash Select II-POS40000 Wiring

POS4000	Wash Select II connector J22
Pin 1 – White	Pin 1 – White
Pin 2 – Red	Pin 2 – Red
Pin 3 – Black	Pin 3 – Black
Shield – Not connected	Shield, strap to base mounting bolt in case.

4. If the POS4000 is connected and both units are powered, the RX light on the 485 communications module should be blinking every couple of seconds. If neither of the lights is blinking, you may have a failed connection or a failed POS4000. A failed communications module may also be possible.
5. Enter the POS4000 link sub-menu and enable the interface. (See Section 2.13.1.)
6. If you have more than one unit, set the bay address per the instructions in Section 2.13.2. (Car wash bay 1 should be set up as unit 2.)
7. Place the unit in operate mode. At this point, you should see both the RX and the TX lights on the Wash Select II 485 communications module begin to blink in an alternating fashion at intervals of a second or less. (If you have more than one bay, the RX light should stay on longer than the TX light.)
8. Place the unit back into setup mode.
9. Configure the Convey Accounting settings. (See Section 2.13.4.)

2.13.1 Interface Mode

The interface mode configures the Wash Select II to listen and respond to POS4000 messages or to enable the Multi-Unit link. Once this mode is enabled, the Wash Select II will respond to messages sent by the POS4000 or a master Wash Select II Unit. It will also allow codes purchased at the master POS4000 or a master Wash Select II unit to be used at a secondary Wash Select II at your site. If at any time this feature is disabled or the unit loses communication, you will get a message on the POS4000 that indicates “Time Out From Unit “X”. (The “X” denotes the number of the unit, bay or other POS4000 (if there is more than one POS4000) unit that has lost communication.) To configure the interface mode, follow the steps below.

1. Place the WSII in Setup mode. Scroll to: POS4000 Link (*) Interface Mode (*)
2. Press the (0) key for “ALONE” (just one Wash Select II), the (1) key for “WS2/POS” (Wash Select II and POS4000 units) or the (2) key for “Multi-Unit Link” (multiple Wash Select II units).

Default: 0

2.13.2 Notifications

You can have any notifications that are normally sent to the pager printed at the POS4000 as well.

1. Place the WSII in Setup mode. Scroll to: POS4000 Link (*) Notifications (*)
2. Enable or disable print errors by selecting Yes or No, respectively.

2.13.3 Set Bay Address

2.13.3.1 Set POS4000 Bay Address

The POS4000 network allows for up to four entry systems to be connected to the same “Master” POS4000. Units are denoted by the network address. Entry systems units are assigned bay addresses 2-5. Bay number one should be configured as bay address two (default).

 **Note:** The Master POS4000 will always be network address one.

If you have a multi-bay system, you need to change the settings as follows:

Table 5. POS4000 Bay Numbering

Bay Number	Bay Address
1	2 (Default)
2	3

3	4
4	5

To set the bay address, follow the steps below.

1. Place the WSII in Setup mode. Scroll to: POS4000 Link (*) Set Bay Address (*)
2. Enter the "Bay Address" of the unit you are configuring, and then press the (*) key.

2.13.3.2 Set Multi-Unit Fleet Bay Address

The Wash Select II multi-unit function is not applicable when interfacing with the WashPay server. The WashPay server tracks activity on all units.

2.13.4 Convey Accounting

This feature allows the POS4000 to receive information when cash or other forms of payment are used at the Wash Select II coin box. If you choose to not have accounting information conveyed (you may do this in the case of revenue sharing if codes are being sold by a partnering merchant), all coin-box accounting information is withheld from the POS4000. Follow the steps below to enable/disable the "Convey Accounting" feature.

Table 6. Conveying Accounting

Use	Setting
Carwash and store where POS4000 is located are owned by the same person(s)	Yes: Enabled (default)
Carwash and store where POS4000 is located are owned by 2 separate persons (revenue share)	No: Disabled

1. Place the WSII in Setup mode. Scroll to: POS4000 Link (*) Convey Accounting (*)
2. Press the (1) key for "YES" (enabled) or the (3) key for "NO" (disabled).

[THIS PAGE INTENTIONALLY LEFT BLANK]

3 Daily Operations

Once the WSII is setup, the only functions needed on a day-to-day basis are reporting, fleet account management and reporting, cash reconciliation, and diagnostics.

3.1 Reporting Menu

The Reporting menu allows you to access, view, and print (if the thermal printer option has been purchased) system reports from the Wash Select II.

3.1.1 Configuration Report

The configuration report shows the most up to date configuration of the system. These are the settings that can be configured while in setup mode. They are categorized on the report based on their typical use. As explained above, the report can either be viewed at the unit or printed. For the most complete reporting, the printed report is recommended.

To print a configuration report:

- Place the WSII in Setup mode. Scroll to: Reporting (*) Print Config (*)

To view a configuration report:

- Place the WSII in Setup mode. Scroll to: Reporting (*) View Config (*)

3.1.2 Accounting Report

The reports found in the WashPay server should be used for all accounting information. The Wash Select II still maintains an accounting report that provides a list of transactions made on the Wash Select II.

To print an accounting report:

3. Place the WSII in Setup Mode. Scroll to: Reporting (*) Print Accounting (*)
4. Next, you will be given two options, 1 = Detailed, and 2 = Summary. Press the proper key, and then press the (*) key to enter.

To view an accounting report:

1. Place the WSII in Setup Mode. Scroll to: Reporting (*) View Accounting (*)
2. Using the (3) key, scroll through the accounting report.

To clear an accounting report:



Note:

This menu option will clear all accounting information. Be sure you have an accurate record of your accounting information, as the information will be irretrievable once this procedure is performed.

1. Place the WSII in Setup Mode. Scroll to: Reporting (*) Clear Accounting (*)
2. Press the (1) key for YES or the (3) key for NO.

3.2 Fleet Accounts and Coupons Menu

Fleet Accounts are setup in the WashPay server. For further instructions, please see the *Sierra Management Application Programming Manual* at www.StartwithUnitec.com.

3.3 Cash Reconciliation

The cash reconciliation function allows you to track the cash inserted to or withdrawn from the Wash Select II unit to keep accurate accounting of cash. When this function is used, it will reset the cash totals. You must setup a pass card or pass code to access the cash reconciliation functions.

Note: the Cash function should be used whenever change is restocked or cash is removed from the WSII. Failure to do so will cause the cash report to be inaccurate and could cause false alert notifications to be sent).

3.3.1 Removing Cash

When removing cash, you must remove ALL cash from the bill acceptor or coin acceptor in order for the WSII to report accurate amounts. Upon completion of the withdrawal, the WSII printer will issue a receipt listing the amounts removed and updated cash balances. The transaction is also recorded in the WashPay server.

To remove cash from the WSII unit:

1. Swipe the pass card or enter the pass code.
2. The display will prompt "Remove or Add?" Press 1 to select Remove.
3. The display will prompt "Bills or Coins?" Press 1 for bills, or 3 for coins.
4. Remove all cash. Remember to take the printer receipt.

3.3.2 Adding Cash

To add cash to the WSII unit:

1. Swipe the pass card or enter the pass code.
2. The display will prompt "Remove or Add?" Press 3 to select Add.
3. The display will prompt "Number of Coins?" Enter the number of coins that will be added to the hopper.

Upon completion of the withdrawal, the WSII printer will issue a receipt listing the amounts added and updated cash balances. The transaction is also recorded in the WashPay server.

3.4 Diagnostics Menu

The Diagnostics menu contains diagnostics functions that are used for troubleshooting and testing the Wash Select II system components.

3.4.1 Testing Output Relays

In this sub-menu, you may turn each of the Wash Select II outputs on or off. To test the output relays:

1. Place the WSII in Setup mode. Scroll to: Diagnostics (*) Test Outputs (*)
2. Once you are in the "Test Outputs" menu you may turn the following outputs on or off, by pressing (1) for YES or (3) for NO. (You may scroll to the next option using the (3) key.)
 - Wash Relay 1 – output to car wash controller
 - Wash Relay 2 – output to car wash controller
 - Wash Relay 3 – output to car wash controller
 - Wash Relay 4 – output to car wash controller
 - Wash Relay 5 – output to car wash controller
 - Wash Relay 6 – output to car wash controller
 - Wash Relay 7 – output to car wash controller
 - Wash Relay 8 – output to car wash controller
 - Bill Enable – Signal to bill validator (not bill validator power)
 - Coins Enable – power to coin acceptor
 - Fault Relay – output to external device such as car wash controller
 - Warning Relay – output to external device such as car wash controller
 - Auxiliary 1 – spare output on display I/O board for external fleet card
 - Auxiliary 2 – spare output on display I/O board for external fleet card
 - Auxiliary 3 – spare output on display I/O board for external fleet card
 - Auxiliary 4 – spare output on display I/O board for external fleet card
 - RFID Light – Toggle Speedpass light on and off
 - AWID Power – Toggle power to ReachFree ID reader on and off

3.4.2 Cycling Output Relays

This function will cycle through all Wash Select II outputs. For a list of the outputs, see Section **Error! Reference source not found.** above. Follow the steps below to cycle output relays:

**Note:**

Disconnect the Wash Select II unit from the car wash equipment prior to running this function. Running this function while connected to a car wash will produce inaccurate results.

Place the WSII in Setup mode. Scroll to: Diagnostics (*) Cycle Outputs (*) and cycling will begin

Each output will turn on for one second, and then proceed to the next output. All outputs will be turned off at the beginning of the test and again upon test completion. You may stop or pause the test at anytime by pressing the (3) key to pause and the (#) key to cancel.

3.4.3 Testing Inputs

With this function, you can test the discrete inputs of the Wash Select II. Follow the steps below to test the inputs.

Place the WSII in Setup mode. Scroll to: Diagnostics (*) Test Inputs (*)

Once you are in the “Test Inputs” sub-menu, the following inputs may be tested.

- Coins Present – on when coins are present in the Change Dispenser Hopper
- Proximity – on when there is a car in front of the coin box
- Wash-in-Use – on when the wash is in use
- Wash Warning – on when there is a warning from the car wash, this is an optional input
- Wash Fault – on when there is a fault with the car wash (wash is down), this is an optional input
- Auxiliary 1 – spare output on Display I/O board for EXT Fleet card
- Auxiliary 2 – spare output on Display I/O board for EXT Fleet Card

3.4.4 Testing Coin and Bill Pulse Relays

Using this feature, you can test the coin dispenser and the bill validator without affecting the account report. This test also allows you to enter cash without having the cash acceptance disabled as it would automatically do in normal operational mode once you have paid for the most expensive wash.

To enter the “Test Bills/Coins” menu, follow the steps below.

1. Place the WSII in Setup mode. Scroll to: Diagnostics (*) Test Bills/Coins (*)
2. Begin to insert coin, bills, or tokens.

The main display screen will show the total cash and tokens. The wash display screens will show the pulse count for each input. You may clear the totals at any time by pressing the (*) key.

Inputs for the USA version (Country Code = USA) are defined as follows:

Table 7. Bill/Coin Inputs

Input	Pulse Input
\$1 bill credit pulse	Bill Input 0 Note: VIP wash coupons will pulse as follows: 12 pulses: coupon 1 13 pulses: coupon 2 14 pulses: coupon 3. The Wash Select II recognizes these pulses as VIP coupons.
\$5 bill credit pulse	Bill Input 1 (not implemented)
Quarter credit pulse	Coin Input 1
\$1 coin credit pulse	Coin Input 2
Token credit pulse Token value configured in Cash/Token Settings	Coin Input 3
Spare (not used)	Coin Input 4

 **Note:** The pulse inputs for the bill validator are as follows: a \$5 bill will show five pulses on bill input zero and a \$10 bill will show 10 pulses on bill input zero.

3.4.5 Test Coin Dispenser

This function will allow you to test the coin dispenser. It will allow you to dispense up to 100 coins. Use of this function will not affect the accounting report. To use this function follow the steps below.

1. Place the WSII in Setup mode. Scroll to: Diagnostics (*) Dispense Coins (*)
2. The main display will prompt "Enter # to Dump?". Enter the number of coins you would like to have dispensed and then press the (*) key to enter.
3. Once the coin dispenser has dispensed the coins, count them to be sure it has dispensed the amount you requested.

3.4.6 Testing the Magnetic Card Reader

Using this function, you can test your card reader's ability to read a magnetically striped card. The test will recognize standard credit/debit cards, Pass Cards, GiveX cards, and VIP Wash Pass cards. There are three types of diagnostics you can perform: Check Tracks, Card Data, and Card Type.

Using the Check Tracks command, you can read the exact track data read by the card reader. This enables you to verify that the card reader is able to correctly read both tracks on the magnetic card stripe.

Follow the steps below to test the magnetic stripe tracks:

1. Place the WSII in Setup mode. Scroll to: Diagnostics (*) Test Card Reader (*) Check Tracks (*)
2. Insert any type of card; you should be prompted to "Remove Card". If you do not see the "Remove Card" prompt, your card reader may be dirty (use a card cleaner) or defective.
3. Remove the card. The main display should show you the status of each of the tracks. The track data will appear in the displays below. Use the (1) or (3) keys to scroll left or right respectively through the displayed data.
4. Press the (#) key to exit this command.

Use this function to test your card reader's basic ability to read a magnetically striped card.

Follow the steps below to test the Card Reader:

1. Place the WSII in Setup mode. Scroll to: Diagnostics (*) Test Card Reader (*) Check Data (*)
2. Insert any type of card; you should be prompted to "Remove Card". If you do not see the "Remove Card" prompt, your card reader may be dirty (use a card cleaner) or defective.
3. Remove the card. The main display should show you the account number on the card, as well as the name if found. If you are using a Pass Card or a VIP Wash Pass card, the main display will show "VIP Wash Pass" and the number that is on the card you used for the test.
4. Press the (#) key to exit this command.

This command will display the type and status of the card you are swiping.

Follow the steps below:

1. Place the WSII in Setup mode. Scroll to: Diagnostics (*) Test Card Reader (*) Card Type (*)
2. Insert any type of card; you should be prompted to "Remove Card". If you do not see the "Remove Card" prompt, your card reader may be dirty (use a card cleaner) or defective.
3. Remove the card. The main display should show you the type of card inserted and its status.
4. Press the (#) key to exit this command.

3.4.7 Testing the Thermal Printer

This feature will test your thermal printer. Any existing error condition messages will be displayed in the main display window.

1. Place the WSII in Setup mode. Scroll to: Diagnostics (*) Test Thermal Prt (*)
2. At this time, the printer will begin to print and/or show any necessary error condition.

Below you will see a sample of the printer test printout. The text will be printed four times.

```

Abcdefghijklmnopqrst
uvwxyzABCDEFGHIJKLMN
OPQRSTUVWXYZ12345678
90!@#$%^&*() + | , . / > <

```

For an explanation of printer error codes refer to the following table.

Table 8. Printer Error Codes

Error Message	Possible Reasons
Receipt Printer not enabled	Printer feature is not enabled. Enable printer in Misc Setup Menu.
Printer not conn[ected] or Hardware Err[or]	Printer control board is not connected to CPU board via ribbon cable. Printer control board is faulty.
Head lever is in Head up position	Printer mechanism head lever (on right side of printer) is in up position. Move the lever to the down position.
Printer voltage Error	Check for 24V power to Printer control board at J4 (pins 1&2) and at J5 (Red & Black wires).
Auto Cutter Error	Auto cutter connector to Printer control board is not connected (CN3) Auto cutter is jammed. This can be UN-jammed in the field Auto cutter is faulty.
Thermal Head Temperature Err[or]	Printer mechanism head is overheated or one of the cables from the mechanism to the control board is broken or disconnected.
Return Waiting Status	One of the connectors from the mechanism to the printer control board is disconnected or the Auto cutter is not working.
Printer is out of Paper	Printer is out of paper or a paper sensor is faulty. Also check that all wires from printer mechanism to printer control board are connected.
Printer is still Printing	Printer control board believes the printer is still printing. Reset the printer by pressing the reset button. This is located near the top of the CPU board next to the feed button. DO NOT Press the reset button on the middle right side of the CPU board.

3.4.8 Testing the Standard Keypad

Using this function will allow you to test the Wash Select II keypad. To test the keypad, follow the steps below.

1. Place the WSII in Setup mode. Scroll to: Diagnostics (*) Test Keypad (*)
2. Press each key on the keypad. As you press each key, the main display should show the number or symbol of that key. To abort testing at any time, press the wash button labeled "Cancel" to exit.

3.4.9 Testing the Buttons

This function will allow you to test the four wash buttons and the change button. The following steps will assist in testing the buttons.

1. Place the WSII in Setup mode. Scroll to: Diagnostics (*) Test Buttons (*)
2. Press each button one at a time. As you press each button, the main display should show the wash number that each button corresponds to (1-4) and a "C" when the change button is pressed.

3.4.10 Test Exp. Memory

An expansion memory chip will be located at connector U57 on the CPU board. To ensure that the expansion memory is working properly, follow the steps below.

1. Place the WSII in Setup mode. Scroll to: Diagnostics (*) Test EXP. Memory" (*)
2. "PASSED" or "FAILED" will appear in the main display window depending on the outcome of the test.

3.4.11 Test RFID (AWID)

To ensure the ReachFree ID system is reading the tags properly. Once the reader antenna is installed and vehicle tag is detected by the reader, the 8-digit code will be displayed in the third window on the Wash Select II door. As long as the RF tag remains in range of the reader, the WSII will beep once per second. You can determine the area the RF Reader can read tags by moving the tag around and listening for the beeps. As long as the unit is beeping once per second, the RF tag is in-range.

The *Diagnostics>Test RFID (AWID)* function also has a power adjustment. All RFID boards are shipped with the power adjustment set to 5. If you need to adjust the power for the reader, enter a number from 1-9 on the keypad. The power levels range from 1 to 9, with 9 being the highest.

3.4.12 Inapplicable Diagnostics with WashPay Integration

When the Wash Select II is integrated with the WashPay site server, The following diagnostics are no longer applicable:

- Testing the Modem
- Get Network Info
- Modem Loop back
- POS/485 Loop back

4 Component Operation & Maintenance

This Section contains instructions for component operations and maintenance. Routine maintenance tasks must be performed regularly to ensure that your Wash Select II continues to operate at maximum efficiency.

4.1 Component Locations

The following line drawing provides a general overview of where the Wash Select II primary components are located. The printer, token bucket, printer controller board, intercom board, card reader, and proximity sensor are components that can be added by purchasing the corresponding option package.

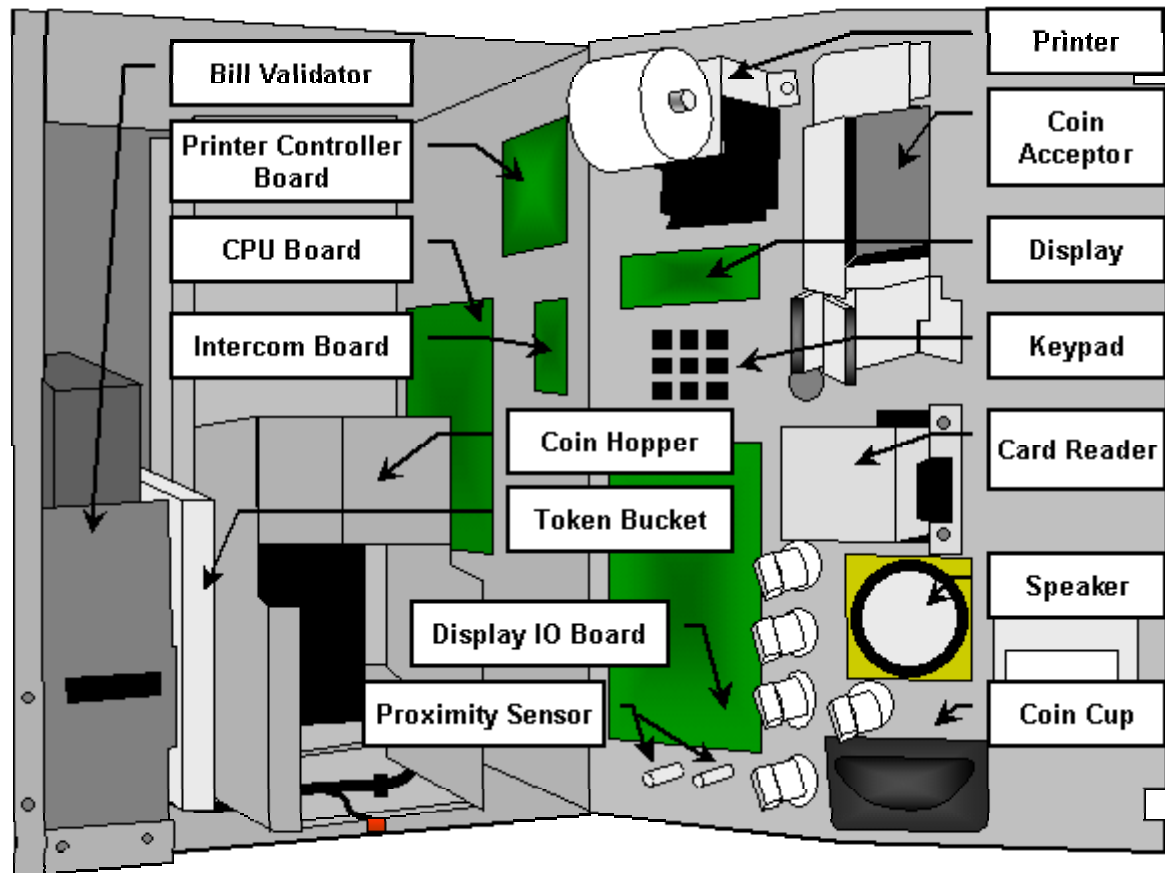

Figure 4. Wash Select II Internal Component Locations

4.2 Software Updates

To upgrade the WSII software, perform the following procedures:

1. Remove the existing EPROM located at connection U58 on the CPU board (see Figure 5) by inserting a small flat-blade screwdriver between the EPROM and the socket and prying it off. Be careful not to damage the socket or the circuit board.

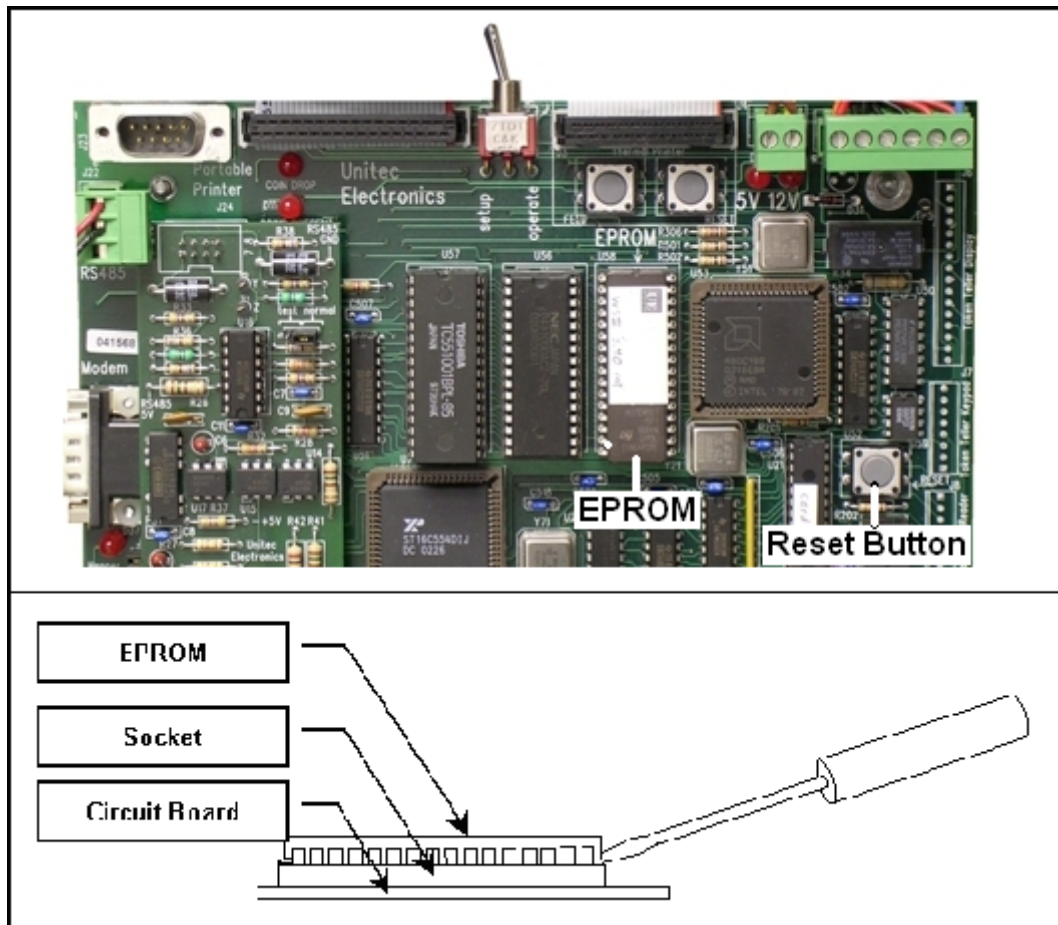

Figure 5. Locating the EPROM and Reset System Memory Button



Caution: Take care not to damage any pins when removing or installing chips.

2. Insert the new EPROM into the socket on the board. Chip pins may need to be adjusted to fit into the socket. Use the following steps to adjust the pins:
 - Lay the chip on its side with the pins facing away from you.
 - Gently rock the chip away from you to bend the pins.
 - Lay chip on its other side and rock it away from you.
 - Repeat the above steps, alternating sides of the chip, until pins are at approximately a 90-degree angle and line up in the socket.

3. The notched end of the chip goes up. There is a silk-screened image on the CPU board you can use to line up the notch correctly. This image is labeled EPROM.
4. Push the EPROM chip in gently. Do not force it, as you may cause damage to the chip or the CPU board.
5. Press the Reset System Memory button. Once the button is pressed, the system will ask if you'd like to clear all memory or keep accounts. Press 1 to reset all memory, or press 2 to reset all but the fleet accounts.
6. Replace the protective plastic cover over the CPU board.

4.3 Bill Validator

The standard Wash Select II comes equipped with the MARS bill validation unit to stack bills up to \$20 in value (NOTE: \$20 bill acceptance is disabled at the time of shipment). To ensure maximum performance by the unit, it will be necessary to read this Section in its entirety.

4.3.1 Mars Bill Validator

The Mars bill validator is provided as an optional choice of bill validator. This bill validator does not support the VIP Wash Coupon feature.

4.3.1.1 Emptying the Bill Stacker

The bill stacker will hold up to 1,000 bills and is designed to allow quick and easy removal of stored money. To empty the bill stacker, hold the validator with one hand pushing the blue lock at the top of the validator with one of your fingers. With your other hand, lift the stacker upward to remove it.

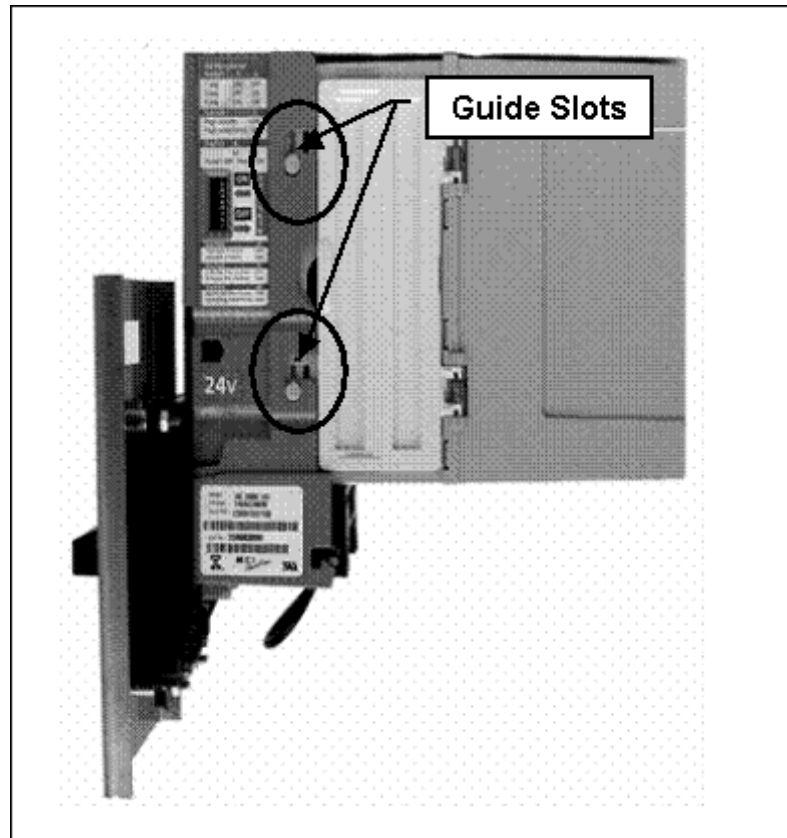

Figure 6. Mars Bill Validator/Stacker

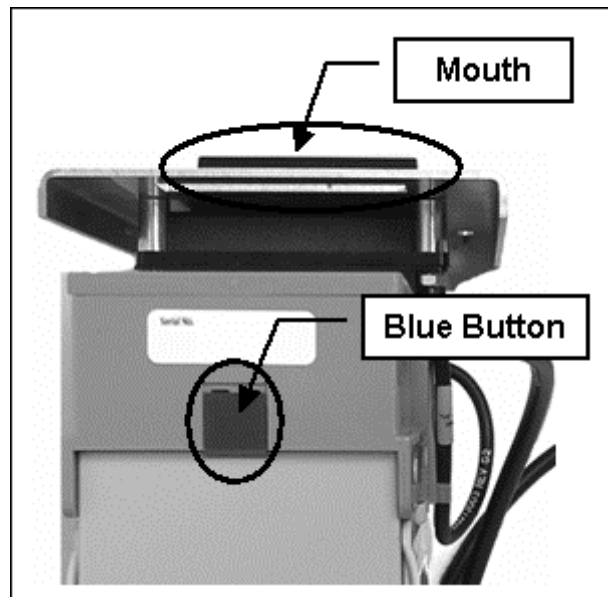

Figure 7. Mars Bill Validator—Top View

4.3.1.2 Replacing the Stacker

To replace the stacker, perform the following steps:

1. Position the stacker behind the Mars Bill Validator with the hinged doors on the side, and the back of the stacker facing away from you.
1. Place the stacker against the bill validator.
2. Align the tabs on the bill stacker just above the guide slots on the bill validator.
3. Slide the stacker tabs into the guide slots, and then down until it is fully seated, as shown in Figure 8.

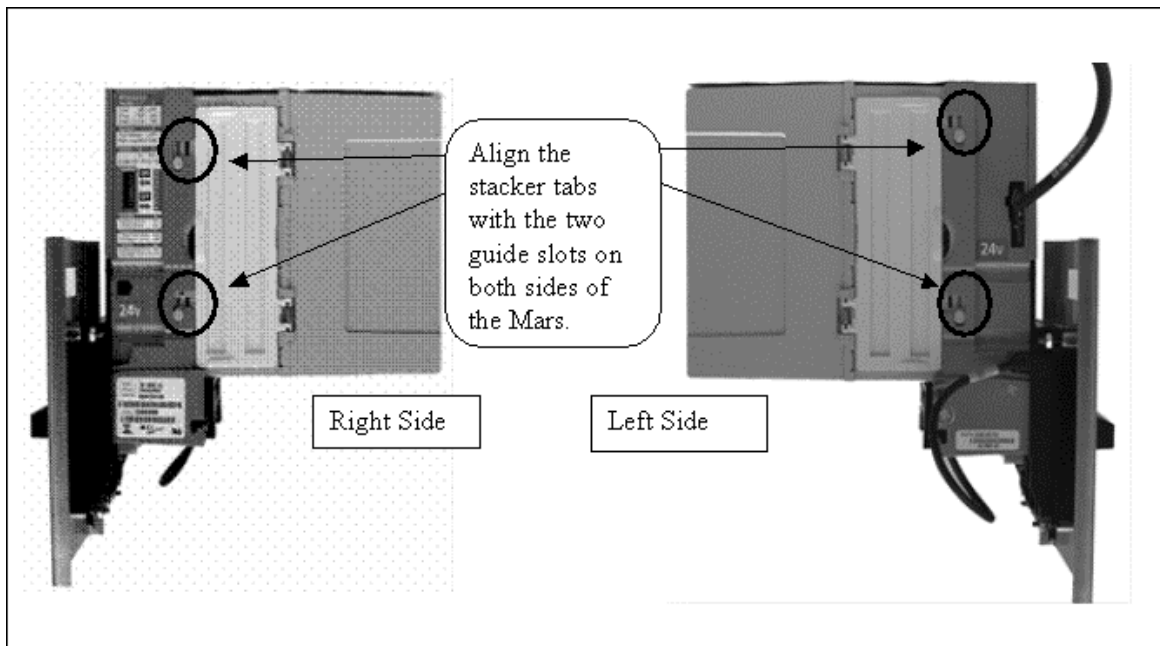

Figure 8. Mars Bill Stacker Replacement

4.3.1.3 Mars Bill Validator Flash Codes

The Mars Bill Validator is equipped with an internal diagnostic LED flash code system. This LED flash code system is used to alert the operator of a failure or to indicate a need for servicing.

The flash code LED is located in the lower section of the validator, below the stacker. See Figure 9 for the LED location.

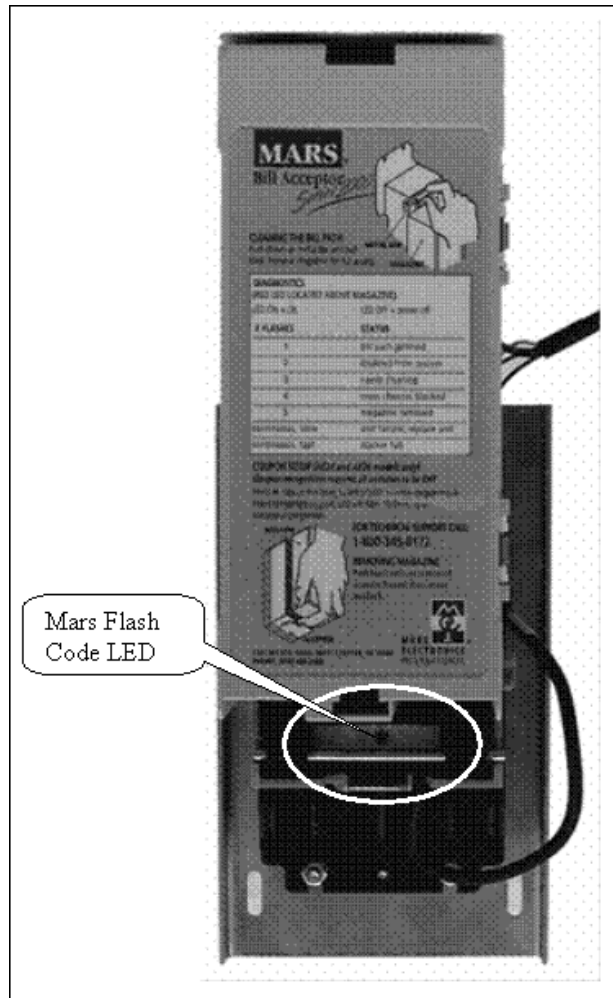

Figure 9. Mars Flash Code LED

The LED will repeat a specific number of flashes. Each number of flashes corresponds to a specific problem. Table 9 lists the meaning of each set of flashes. Many of these problems may be easily corrected without the need for technical assistance.

Table 9. Mars Bill Validator Flash Codes

# Flashes	Diagnostic Code Description
1	Bill path jammed
2	Disabled from system
3	Needs cleaning
4	Cross channel blockade
5	Magazine (stacker) removed
Continuous slow	Unit failure, replace unit
Continuous fast	Stacker full
LED on	Ok

# Flashes	Diagnostic Code Description
LED off	Power off

4.3.1.4 Removing the Mars Bill Validator From the WASH SELECT II

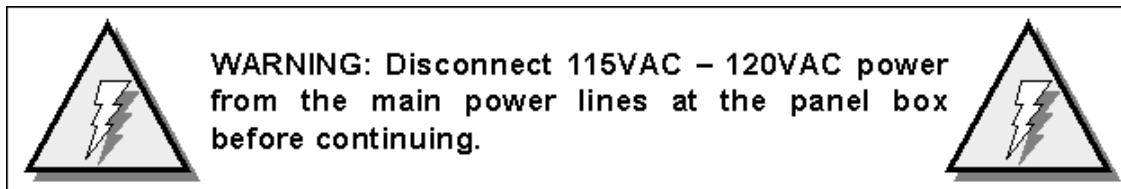

Perform the following steps to remove the Mars Bill Validator.

1. Unlock and open the door of the WASH SELECT II.
2. Power off the WASH SELECT II.
3. Hold the Bill Validator at the top.
4. Remove the two Phillips head screws on the left side of the Bill Validator faceplate.
5. Remove the two Phillips head screws from the bottom of the Bill Validator faceplate. (Be careful not to yank, tear, or rip out the wires connected to the Bill Validator).
6. Once the wires on the right side of the Bill Validator are in view, grasp them at the connector and disconnect them by gently rocking them back and forth.

4.3.1.5 Removing the Mars Bill Validator Lower Housing

If necessary, the bill validator lower housing can be removed using the following procedures. The lower housing is the portion of the Bill Validator that sits just below the stacker and behind the bill mouth. The bill mouth is the part of the bill validator that is used to pull in and analyze the bills that have been inserted. Bills are pulled in by a system that draws them up into the main body. Once they have been pulled in, four photo-optic sensors are used to scan them and send the information to the electronics.

Perform the following steps to remove the Mars Bill Validator lower housing.

1. Remove the Bill stacker. (See Section 4.3.1.1)
2. Reach under the bottom of the validator and locate a silver rod in the area below where the status LED is located. (See Figure 10)
3. Using your thumb, push the silver rod up toward status flash code LED.
4. Firmly grasp the top of the housing with your fingers and pull the lower housing toward the palm of your hand. (Be sure to keep steady pressure on the housing at all times during removal.)
5. Slide the inner housing out of the back of the validator, revealing the belts, pulleys and sensors.

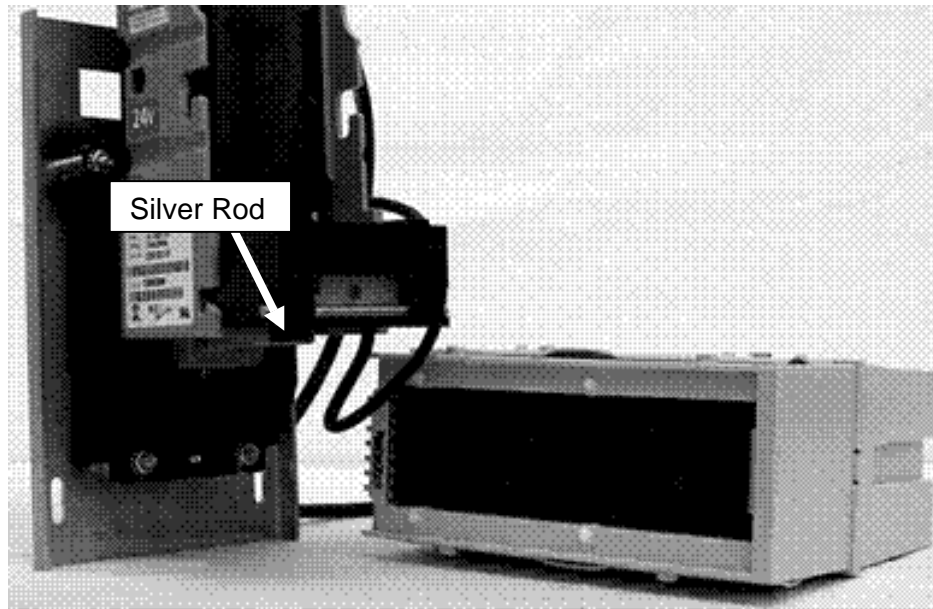

Figure 10. Mars with Lower Housing

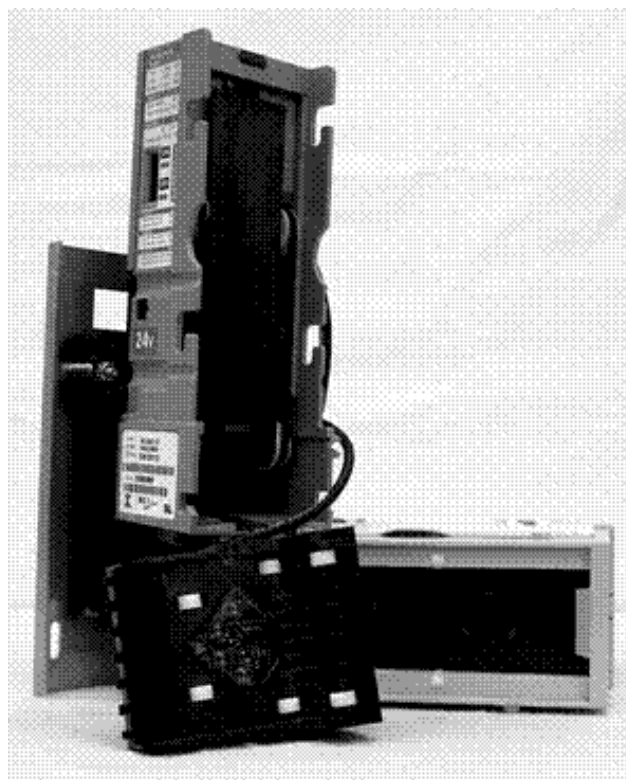

Figure 11. Mars with Lower Housing Removed

4.3.1.6 Cleaning and General Maintenance

The AE2600 series will not need cleaning as often as magnetic sensing bill validators. If cleaning is required, use a soft cloth moistened with mild, non-abrasive detergent.

4.3.1.7 Programming the Mars Bill Validator

The Mars Bill Validator allows programming for a maximum-security setting, as well as a setting for a specified direction that a bill can be inserted. These options are set by a DIP switch package located on one side of the validator.

To change any of the options, perform the following steps.

1. Remove the Mars Bill Validator from the unit. (See Section 4.3.1.2 for instructions.)
2. Referring to Table 10, use a small flat-head screwdriver to set the DIP switches for the options you prefer. (See Figure 12 for DIP switch location.)

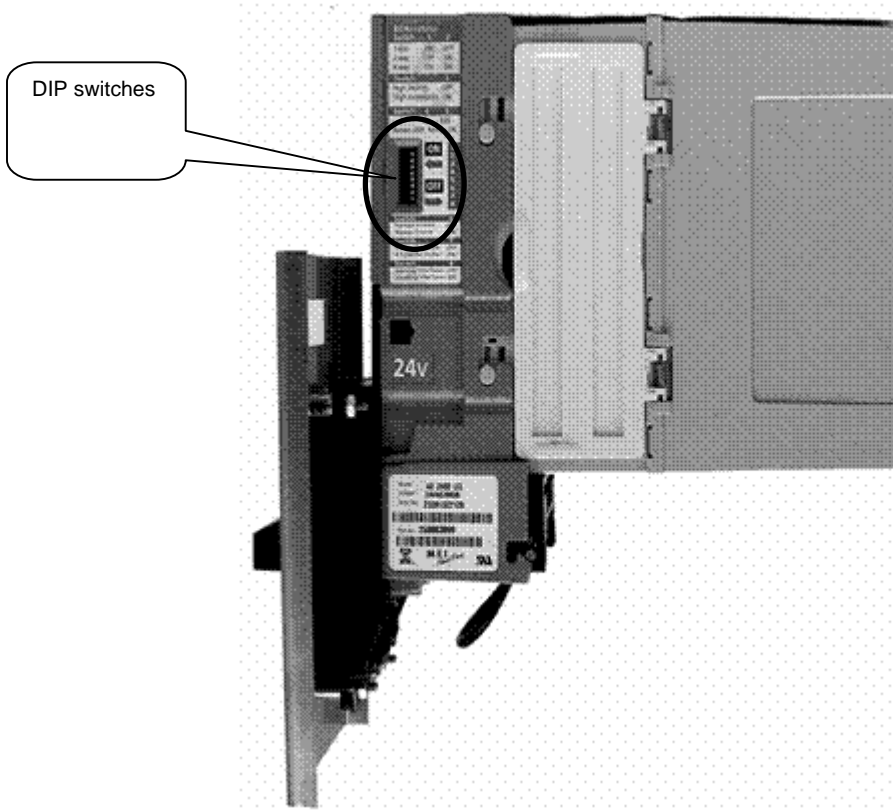

Figure 12. Mars DIP Switches

Table 10. Mars Bill Validator DIP Switches

Switch	ON	OFF	Default
--------	----	-----	---------

Switch	ON	OFF	Default
1 & 2 (switches work in combination)	1 & 2 both ON = 4-way bill acceptance	1 ON, 2 OFF = 1-way bill acceptance	1 OFF, 2 ON = 2-way bill acceptance
		1 OFF, 2 ON = 2-way bill acceptance	
3	High Acceptance	High Security	OFF
4	Reject \$2 (Should ALWAYS be ON)	Accept \$2 (Should NEVER be OFF)	OFF
5	Reject \$20*	Accept \$20	ON
6	Always Enable	Harness Enable	ON
7	4 Pulse per Dollar	1 Pulse per Dollar	OFF
8	Vending Interfaces	Gaming Interfaces	OFF

4.4 Single Coin Acceptor

The Wash Select II comes standard with the model PEM-35 single coin acceptor. In this section, you will find instruction for proper maintenance of the PEM-35.

4.4.1 Replacing the Reference Coin

For proper operation of the coin acceptor, you must have a sample of the coin to be accepted (U.S. quarter) in the sample holder. The Slug-Buster II (model PEM-35) comes from the factory with a U.S quarter already in the sample holder.

You may use the following steps to assist you when replacing the reference coin.



Warning: Never loosen a nut on the Slug-buster II that is covered with BLUE or RED paint.

1. Loosen the retainer screw or nut just enough to allow the retainer slot to slide freely.
2. Remove the sample coin currently in the sample holder from the side of the retainer slot.
3. Slide the retainer toward the sensing coil until it is firmly seated. (The sample must be centered in the sensing coil and seated in the "V" groove to function properly.)
4. Once the retainer is back in place, tighten the screw or nut.

4.4.2 Adjusting the Selectivity to the Coins

There should be no reason to change the selectivity of your new unit since it was shipped from the factory with a tested, pre-set coin already installed. However, if you find it necessary

to replace the coin samples with a different type of coin, the selectivity of the unit must be readjusted. Before this can be done, a standard acceptance test should be performed. The test is performed by dropping several valid coins into the Slug-Buster II, including common slugs, and verifying that the proper coins are credited and that the slugs are rejected. If the acceptor does not recognize all of the coins, or does not reject the invalid coins, the following procedure should be implemented.

**Note:**

The coin acceptor must be powered to make a valid adjustment to the sensitivity. You must also avoid testing the Slug-buster II with the door open in direct sunlight. If the Slug-Buster II main mechanism is exposed to direct sunlight, it may fail to credit the coin.

1. Locate the coin holder housing a quarter in the sample holder. Check the coin to ensure it is properly centered in the sensing coils and it is seated securely.
2. Loosen the cover nut to the electronics box on the opposite side of the coin acceptor. Spin the 1" x 2-1/2" cover, exposing the selectivity trim pot.
3. Locate the trim pot in the round hole that has been exposed by spinning the cover. The trim pot is marked "QUARTERS" and controls the quarter selectivity.
4. Begin dropping the quarters or lower value coins into the unit, slowly turning the trim pot marked "QUARTERS" counter-clockwise (ACCEPT), until the Slug-Buster II begins to accept the coins.
5. Turn the trim pot an additional 2–5 degrees counter-clockwise (ACCEPT), and stop. This completes the smaller value coin adjustment.

4.4.3 Removing the Coin Acceptor

If you find it necessary to remove the Slug-Buster from the Wash Select II door, a small head Phillip's screwdriver will be needed.

Follow the steps below to remove the assembly from the door.

1. Locate the rejected coin cup, which is mounted on the front of the Wash Select II door underneath the coin acceptor slot.
2. Using a small Phillip's head screwdriver, remove the screws from the inside of the Wash Select II door that are securing the rejected coin cup. The cup should slide off from the front of the door after removing the screws.

**Note:**

When replacing the coin acceptor, make sure that the exit chute is aligned with the coin diverter/guide assembly properly. Failure to align the two may result in coin jams or loose coins falling to the bottom of the Wash Select II case.

3. Use a 1/4" nut driver to remove the four nuts that are located at the corners of the faceplate. (The screws can be found inside of the Wash Select II door. The lower screws are located next to the rejected coin cup and the upper screws are located just above the coin acceptance slot.)
4. Grasp the unit in one hand and loosen the nuts with the other hand. Once the nuts have been removed, the complete assembly can be removed by pulling it out and away from the Wash Select II door.

4.5 Multi-Coin Acceptor Programming and Operation

This optional item allows the Wash Select II to accept U.S. quarters, dollar coins and up to four different bi-metal tokens. The Wash Select II accepts tokens ranging in size from .984" – 1.125" in diameter.

The current configuration of the Wash Select II only allows one coin to be dispensed at a time. Therefore, if you would like to dispense the dollar coin, it will be necessary to make changes to the coin hopper.

4.5.1 Programming the IDX Acceptor



Note: When inserting coins into the IDX, you must be sure to close the cover completely.

The unit comes equipped to accept both U.S. quarters and dollar coins, and will dispense quarters by default. The unit will also accept site-specific tokens. This section will guide you through the programming of each of the site-specific coins that will be accepted and give details on erasing this program, if a programming error ever occurs.

In order to complete the programming you must have six of each of the tokens and coins you wish to accept. It is very important that you follow these directions exactly. The IDX acceptor will average the variances in these different sample coins during programming, and calculate a more accurate reference model. Using less than six different coins will invalidate the average variance generated by this process.

Please refer to the block diagrams shown in Figure 13 while programming the IDX coin acceptor.

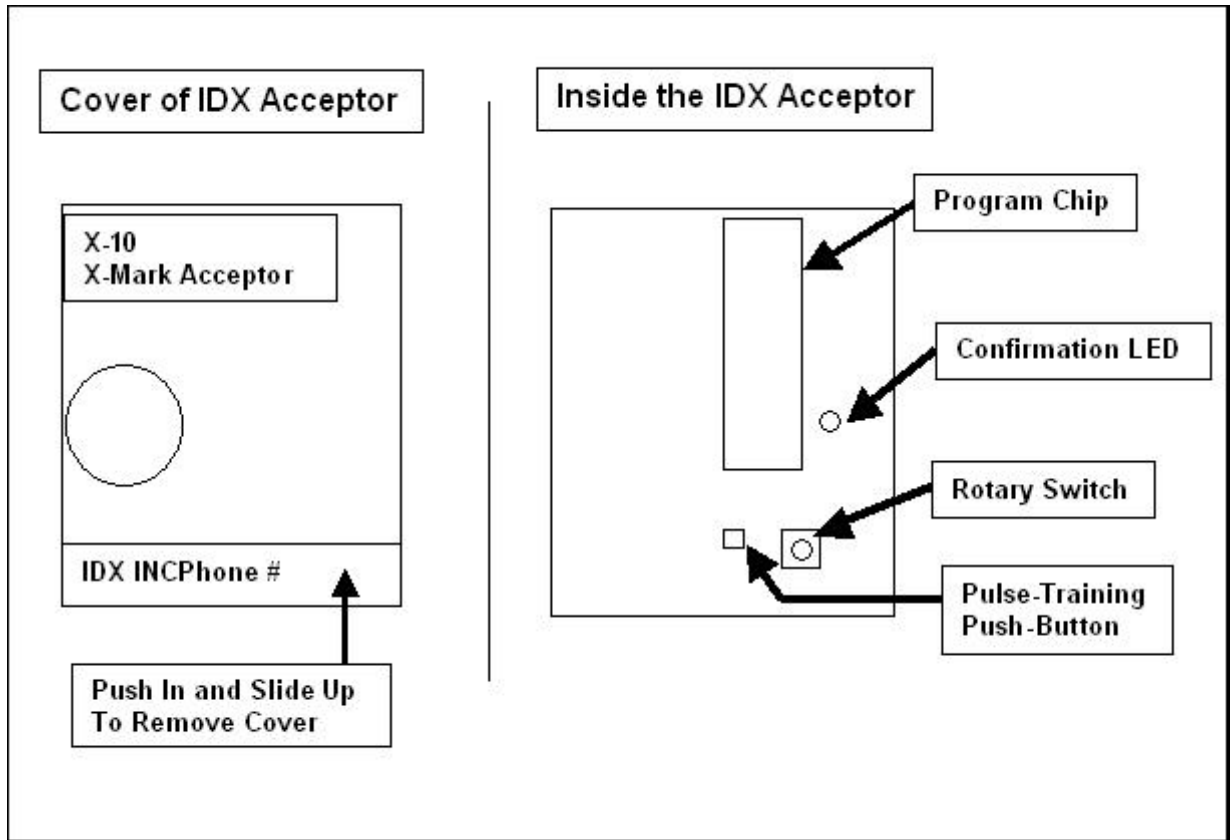

Figure 13. Outside/ Inside of the IDX

You must answer the following questions before proceeding with the programming of the IDX coin acceptor.

- Do you want to accept tokens?
- How many different tokens will your site have?
- How much will each token be worth?
- Can the Wash Select II programmed token-value be divided evenly into each of these values? (This helps to determine the number of pulses the IDX will need to output for each token.)
- Will the Wash Select II dispense quarters or dollar coins?
- How many tokens will be allowed per customer per purchase?

In order to program the IDX to dispense the dollar coin, several physical changes must be made to the IDX acceptor and wire harness. These changes can be made using the table below to help you determine which rotary-switch position corresponds to a particular coin output. The dispensed/diverted coin must always be assigned to output number six, requiring pins four and five to be switched at the green Phoenix-connector at the end of the IDX wire-harness to dispense the dollar coin.

Table 11. IDX Program Configuration

Coins—Quarter	Coins—Dollars	IDX Rotary Switch	Number of Output
---------------	---------------	-------------------	------------------

Diverted	Diverted	Position	Pulses
Token 1	Token 1	1	1-12, 14-255
Token 2	Token 2	2	1-255
Token 3	Token 3	3	1-255
Token 4	Token 4	4	1-255
\$1-Coin	Quarters	5	1
Quarters	\$1-Coin	6	1

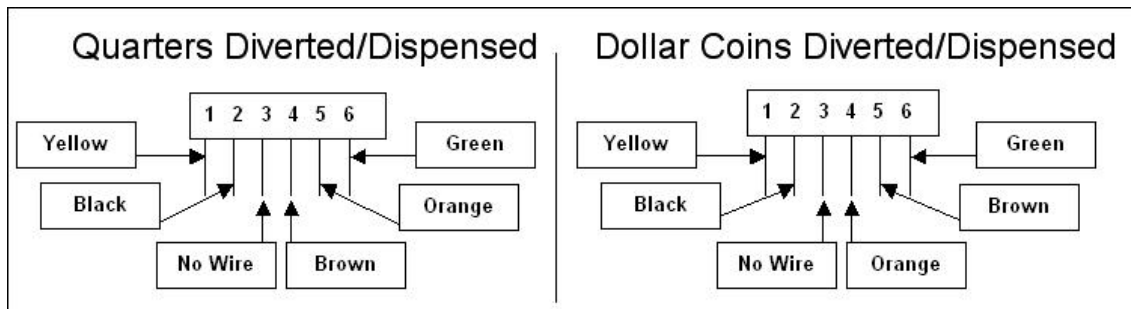

Figure 14. IDX Wire Harness (Green Phoenix Connector) Configurations

Once the configuration has been decided, the number for the switch positions, pulses, and wire-harness pin-outs will need to be substituted for the given numbers in the instructions in Section 4.5.2 below. The number of pulses is programmed by depressing the push-button the desired number of times prior to insertion of the sample/programming coins (see Table 11 above).

4.5.2 Programming the IDX to Accept Site-Specific Tokens

When programming site-specific tokens, it is important that you take into consideration the following items:

- Tokens with a diameter of .984" are commonly used at nationwide arcade/pizza stores. The IDX coin acceptor will accept these tokens if your site-specific token is the same size.
- Compare your token size with any local arcade tokens prior to programming the IDX coin acceptor to accept your site token.

Before you begin programming, be sure that you have six of each token you plan to program. You are responsible for supplying your own bi-metal tokens. Tokens are not available through Unitec.

The IDX acceptor can be programmed to accept four different tokens. Each token will need to be sampled and assigned a number of pulses. This means that each token will need to be worth some multiple of the Wash Select II programmed token value (from the cash & tokens menu); the programmed token value is internally multiplied by the number of pulses sent by the IDX.

(Example: If you have assigned a token value of \$.50 under the “Cash & Tokens” menu, and you have four different tokens, each token must be worth a multiple of \$.50. or as follows token 1 = \$.50, token 2 = \$1.00 token 3 = \$1.50 and token 4 = \$2.00. As you can see each token in this example represents numbers that can be divided by \$.50.) The Wash Select II does not keep a separate accounting of each different token your site may have; it just keeps a running total equal to the total dollar value entered. This total will be reflected on the Wash Select II accounting report.

To program the IDX to accept a single token, follow the instructions below. If more tokens are required, refer to Table 11 to get the switch locations for that particular token, and then depress the push-button the number of times that is equal to the number of pulses to be output for that token.

1. Locate the rotary-switch and set it to position 1, 2, 3, or 4.
2. Press the button immediately to the left of the rotary-switch one or more times depending on the number of pulses you want that token to send.
3. Drop six sample tokens through the coin slot one at a time, and verify that the red light (LED) blinks several times after the last token has been entered.
4. Reset the rotary-switch to “0”, and then replace the front cover.

Now assume your token value is set for \$1.00. To program the IDX acceptor to accept two different tokens, token number 1 for \$1.00 and token number 2 for \$2.00, follow the steps below.

1. Set the rotary-switch to position “1”.
2. Press the button directly to the left one time.
3. Drop six sample tokens into the coin slot one at a time, and verify that the light (LED) blinks several times after the last token is entered.
4. Now set the rotary-switch to position “2”.
5. Press the button directly to the left of the rotary-switch twice (for two pulses or \$2).
6. Drop six sample tokens of the second type into the coin slot one at a time, and verify that the light (LED) blinks several times after the last token is entered.
7. Return the rotary-switch to the “0” position.
8. Replace the cover.

4.5.3 Programming Token Value

If you choose to keep the token value set to the default value, this Section can be skipped. The default token values of the Wash Select II are shown in the table below.

Table 12. Wash Select II Token Values

Value Name		Default Setting	Maximum Allowed
Token Value		\$1.00	\$99.00
Maximum Transaction	Token per	80	80

The following steps will assist you when setting Token Values.

1. Using the toggle switch at the top of the CPU board, place the Wash Select II in setup mode by moving the switch toward the back of the Wash Select II case. (The CPU board is located on the inside right wall of the Wash Select II case.)
2. Using the (3) key to scroll forward and the (1) key to scroll back, scroll through the main menu until the “Cash & Tokens” option is displayed. Press the (*) key to enter.
3. Scroll through this menu until the “Token Value” option is displayed, and then press the (*) key to enter.
4. Enter the token value in cents format, and then press the (*) key to enter. (If you would like to set the token value to \$.75 for example, you would enter 75, and then press the (*) key.)

**Note:**

The token value set will be multiplied by the number of pulses sent by the IDX coin acceptor.

The steps below will assist you when setting the Max Tokens per customer value.

1. Using the toggle switch at the top of the CPU board, place the Wash Select II in setup mode by moving the switch toward the back of the Wash Select II case. (The CPU board is located on the inside right wall of the Wash Select II case.)
2. Using the (3) key to scroll forward and the (1) key to scroll back, scroll through the main menu until the “Cash & Tokens” option is displayed. Press the (*) key to enter.
3. Scroll through this menu until the “Max Tokens/cust” option is displayed, and then press the (*) key to enter.
4. Enter the number of tokens you wish each customer to be allowed to use for a single purchase, and then press the (*) key to enter.

4.5.4 Programming Dispense Value (for \$1 coin dispensing only)

If you want your unit to dispense the dollar coin, the coin-hopper must be modified to accommodate the larger coin. This is described in Section 4.5.5, below. The dispense value of the Wash Select II must also be changed to reflect the value of the dollar coin. The default value for this function is \$.25. To change the dispense value, follow the steps below.

1. Using the toggle switch at the top of the CPU board, place the Wash Select II in setup mode by moving the switch toward the back of the Wash Select II case. (The CPU board is located on the inside right wall of the Wash Select II case.)
2. Using the (3) key to scroll forward and the (1) key to scroll back, scroll through the main menu until the “Cash & Tokens” option is displayed. Press the (*) key to enter.
3. Scroll through this menu until the “Dispense Value” option is displayed, and then press the (*) key to enter.
4. Enter the dispense value in cents form, and then press the (*) key to enter. (If the dispense value of the coin is \$1.00 this must be entered as 100.)

4.5.5 Modifying the Hopper

If you want your Wash Select II to dispense quarters, this procedure is **NOT** necessary. However, if you wish to dispense the dollar coin, the hopper must be modified and the IDX acceptor will need to be programmed. This Section will cover the setup of the coin-hopper. To program the IDX acceptor and the Wash Select II, please refer to Section 4.5.1 of this manual.

4.5.5.1 Disassembling the Hopper

To disassemble the coin hopper, follow the steps below.

1. Locate the coin hopper on the floor of the Wash Select II case.
2. Remove the coin hopper by grasping it by the handle at the top and lifting up and toward the front of the Wash Select II case. Be careful not to damage the cable connector at the back of the hopper.
3. Once the hopper has been removed from the hopper mount, reach behind it and grasp the cable connector. Gently remove the cable from the back of the hopper and lift the hopper out of the Wash Select II case.
4. Once you have removed the hopper from the Wash Select II case, you can remove the two screws that are holding the black, plastic hopper cube. (See Figure 15, below.)

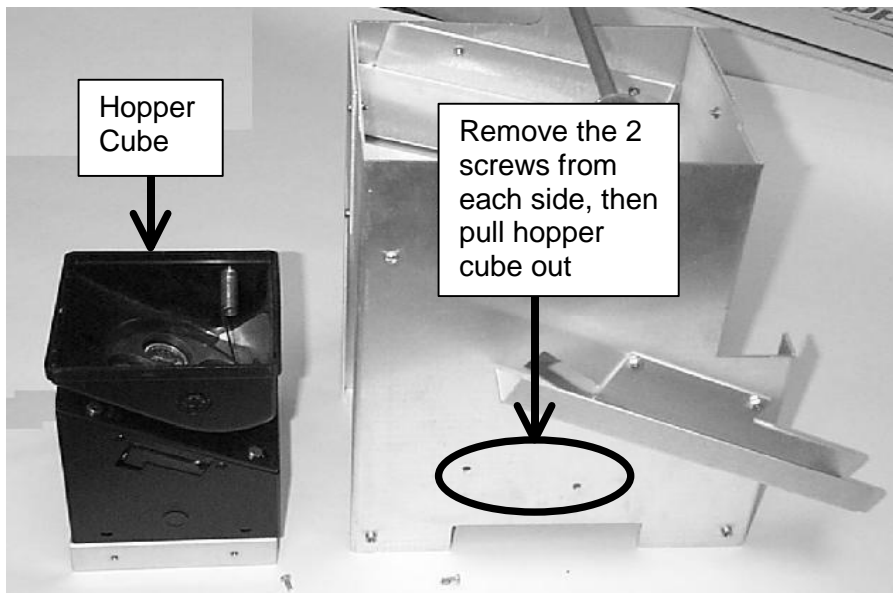

Figure 15. Hopper View - Side Screw and Internal Hopper - Cube

5. Separate the black hopper-cube from the center of the metal body of the assembly, and then slide the red locking clasp, on the side of the black plastic hopper downward.



Figure 16. Hopper View - Removing the Hopper - Cube Top

6. Slide the top piece of the black plastic hopper up and off to expose the wheel.

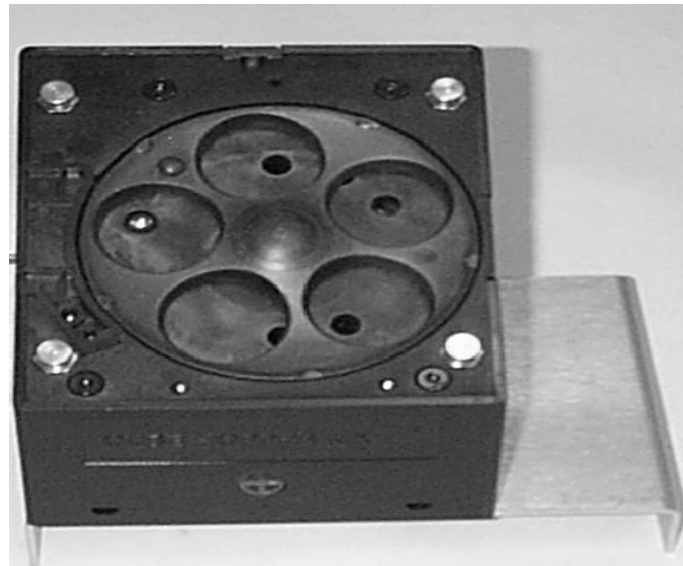

Figure 17. Hopper View - Top Removed

7. Remove the dispensing wheel by grasping the coin openings and lifting up.

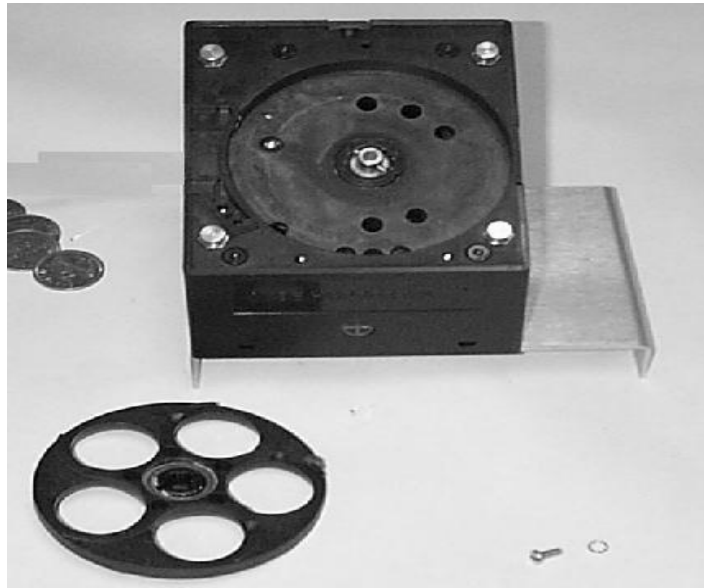

Figure 18. Hopper View - Wheel Removed

8. Using your hand, remove the guide arm cover from over-top of the coin exit opening.

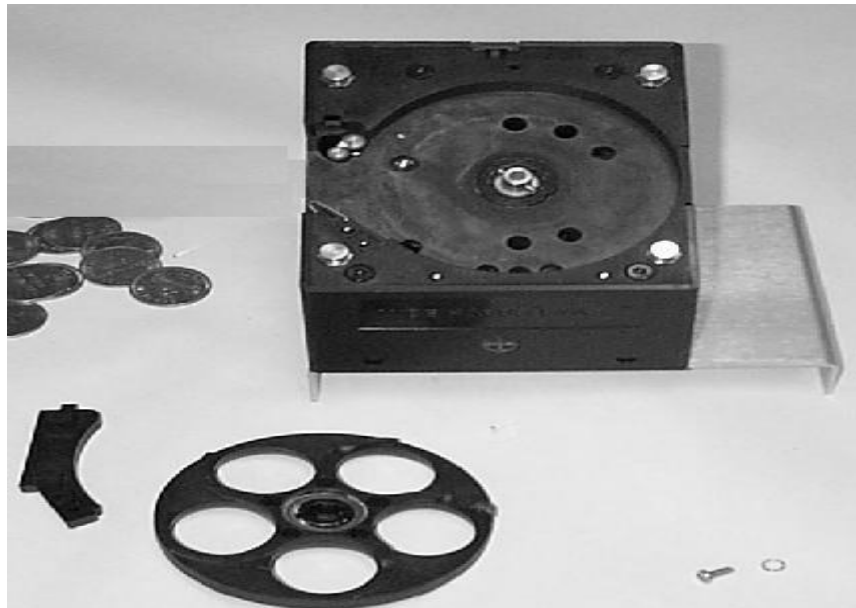

Figure 19. Hopper View - Guide Arm Cover Removed

9. Using a screwdriver, gently pry off the old hopper arm. Be very careful not to break the pins that hold the arm in place.

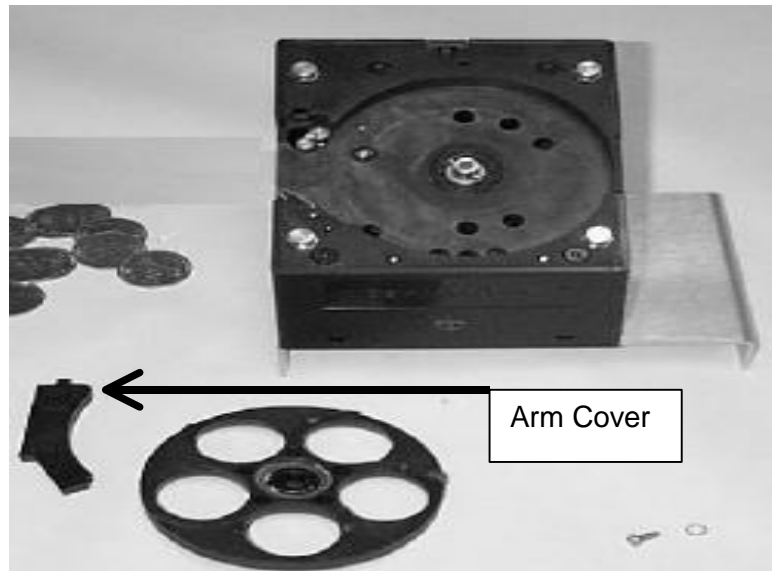

Figure 20. Hopper View - Removal of the Coin Guide Arm

10. Place the new hopper arm into the slot exactly as the old one was.
11. Place the new hopper wheel into the plastic hopper exactly as the old one was.

4.5.5.2 Re-assemble the Hopper

1. Once the new guide arm and dispensing-wheel have been replaced, reinstall the coin guide arm cover. (See Figure 18.)
2. Slide the black plastic top back onto the hopper-cube assembly. Securely latch it in place by locking the clasp.
3. Place the hopper-cube back into the metal housing and replace the two screws you removed previously. Be sure that the coin exit opening of the hopper-cube is properly aligned with the exit chute of the metal housing. (See Figure 21.)

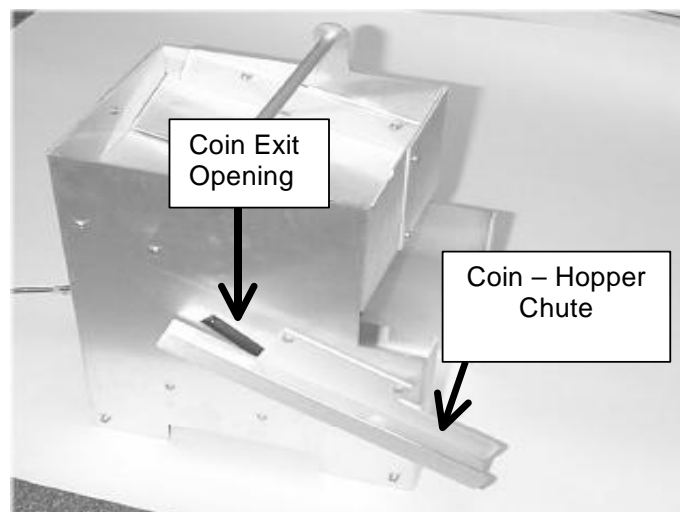

Figure 21. Hopper View - Coin Exit Opening and Chute

4.5.6 Program the IDX to Accept Quarters

Follow the steps below to program the IDX to accept quarters.

1. Remove the front cover by pushing it in and up from the bottom right corner of the main body. (This is located near the phone number.)
2. Locate the rotary-switch and set it to the position labeled number 6. (If you choose to dispense \$1 coins instead of quarters, this will be position 5.)
3. Press the button located immediately to the left of the switch once.
4. Drop six different quarters through the acceptor and verify that the light (LED) blinks after the last quarter has been entered.
5. Move the rotary switch back to the position labeled '0'.

4.5.7 Programming the IDX to Accept \$1 Coins

1. Set the rotary-switch to the position labeled number 5. (This will be position 6 if you wish to dispense \$1 coins.)
2. Press the button located immediately to the left of the switch once.
3. Drop six different dollar coins through the acceptor and verify that the light (LED) blinks after the last coin has been entered.
4. Move the rotary switch back to the position labeled '0'.



Note: The dispensed coin will always be programmed on position 6.

4.5.8 Erasing IDX Programming

If, for some reason, you need to erase programming or if anything should go wrong during the programming process it can easily be corrected by following these steps.

1. Remove the front cover from the IDX acceptor.
2. Set the rotary switch to the position that corresponds to the coin you wish to re-program or erase.
3. Depress the button located immediately to the right of the rotary switch only once.
4. Return the rotary switch to zero without passing any coins through the acceptor. This will erase the program that has been stored for that number.
5. Return the front cover to the IDX.

4.5.9 The Token Bucket

If you have purchased the "Multi-Coin" option, your unit will have a coin diverting mechanism to guide the coins to their appropriate location. If you are accepting quarters, dollar coins and tokens, the diverting mechanism will send the coin you have chosen to dispense (quarters or \$1 coins) to the hopper to be recycled. All other coins will be sent to the token bucket. It is very important that you check you bucket often to ensure it does not overflow.

You can empty the bucket by grasping it firmly at the top and lifting it up and out of the Wash Select II case. When returned to the case, the bucket locks into an upright position using a bracket on the floor of the Wash Select II.

4.5.10 Cleaning and General Maintenance

You are strongly advised to check the coin-accepting system for proper operation. It is a good habit to perform a check each time you remove cash from the box and any other time you may open the box. Customers have been known to insert invalid coins, debris and bills into the coin box. This will clog these systems and render them temporarily out-of-service.

Two other components vital to the proper operation of the unit are the optical sensors of the coin acceptors. These sensors are used to analyze the coins that are entered. Due to their importance, the optical sensors should be cleaned periodically.

A cotton swab daubed in isopropyl alcohol is excellent for cleaning. To clean the sensor, simply use a wet swab to wipe the inner wall area inside the first two inches of the coin slot.

If the unit malfunctions and a good cleaning does not solve the problem, reprogram the acceptor as described in Section 4.5.6 and 4.5.7.

The large inclined plane that protrudes from the top-front part of the bucket is used to guide the coins smoothly into the container. If there is debris or any other substance on it, coins may become trapped or lodged in mid-travel. This should be cleaned using a clean cloth and a mild soap and water solution periodically to ensure proper operation.

4.5.11 System Settings Affecting IDX Coin Acceptor Operations

The following Wash Select II system settings will have an effect on how the IDX Coin Acceptor operates.

Table 13. System Settings Affecting IDX Coin Acceptor Operations

Setting	Effect
Normal Operation	When sufficient payment has been received to cover the cost of the most expensive wash pack, the cash acceptance will be disabled, and the coin acceptor will reject all subsequent coins entered.
Allow Upgrades	When programmed for no upgrades, the unit's ability to accept more cash (or other forms of payment) for the purchase of a better, more expensive wash is disabled.
Country Code	This configures the coin value for each coin input.

4.6 Speech Module

The Speech option consists of the following components:

1. A speech module circuit board, which plugs into the CPU board.
2. A speaker, which is attached to the door.
3. A speaker grille, which is attached to the outside of the door.
4. A speaker cable, which runs from the CPU board to the speaker.
5. A microphone, which plugs into the top of the speech board and is used to record voice messages.

4.6.1 Recording Messages

Before you begin recording your personal speech messages, it is suggested that you study the “Speech Message Script” below. It shows the time allotted for each message and gives the pre-recorded messages already programmed on your unit.

SPEECH MESSAGE SCRIPT

1) GREETING MESSAGE (10.25 seconds)

Hello, welcome to _____ car wash. Please Select your wash or enter your code now.

2) SELECT PACKAGE (4.25 seconds)

Please select your wash package now.

3) PACKAGE 1-PURCHASED (8.5 seconds)

You have purchased the _____. You may enter the wash if it is ready.

4) PACKAGE 2 PURCHASED (8.5 seconds)

You have purchased the _____. You may enter the wash if it is ready.

5) PACKAGE 3 PURCHASED (8.5 seconds)

You have purchased the _____. You may enter the wash if it is ready.

6) PACKAGE 4 PURCHASED (8.5 seconds)

You have purchased the _____. You may enter the wash if it is ready.

7) CODE INVALID (4.25 seconds)

Your code is invalid. Please try again.

8) RECEIPT PROMPT (4.25 seconds)

Would you like to have a receipt?

9) AUTHORIZING (5.75 seconds)

Please wait while your card is being authorized.

10) CARD FAILURE (5.75 seconds)

Your transaction was not authorized. Please try again or use another payment method.

11) HOPPER FAILURE (8.00 seconds)

Your change was not completely dispensed.

12) WASH IS READY (8.00 seconds)

The wash is now ready. Please drive in slowly following the entrance sign on the car wash.

13) EXACT CHANGE ONLY (5 seconds)

Please use exact change only.

14) ADD MONEY NOW (6.75 seconds)

Please add payment for your selection

15) SELECT WASH TYPE (6.75 seconds)

Please Select Soft-cloth or Touch-free now.

16) BAD CARD READ (5.75 seconds)

Your card could not be read. Swipe your card again, or try another card.

17) ENTER PIN (3.25 seconds)

Please enter your PIN number.

18) ENTER DATA (3.25 seconds)

Please enter the requested information.

19) NETWORK ERROR (4.25 seconds)

Sorry, we were unable to process your transaction at this time.

20) SELECT CREDIT/DEBIT (3.25 seconds)

Please select Credit or Debit.

21) ONE MOMENT PLEASE (2.50 seconds)

One moment please.

22) BAD CARD ORIENTATION (5.75 seconds)

Please check your card orientation, stripe to the right.

23) CREDIT TERM CUSTOM (5.00 seconds)

(Customized Credit Terminal Decline Message)

24) SELECT AN OPTION (3.25 seconds)

Please select an option.

When you are ready to record you messages, follow the steps below.

1. Using the toggle switch at the top of the CPU board, place the Wash Select II in setup mode by moving the switch toward the back of the Wash Select II case. (The CPU board is located on the inside right wall of the Wash Select II case.)
2. Using the (3) key to scroll forward and the (1) key to scroll back, scroll through the main menu until the "Speech" option is displayed. Press the (*) key to enter.
3. Scroll through the "Speech" menu until "Record Message" is displayed, then press (*) to enter. Enter the number of the message you want to record and press the (*) key to enter.
4. Plug the provided microphone into the top of the speech board.

5. Locate the volume knob and adjust the volume by turning the knob clockwise about half way. (The knob should have been set fully to the counter clockwise at the factory.)
6. Speak clearly and loudly into the microphone to record each message. (Hold the microphone straight up and down, even with the middle of your chin for best results.)
7. Scroll to the "Play Message" option and press (*) to enter. Listen to the message to be sure you are happy with the sound quality and to check the accuracy of the message.
8. Once you have recorded all messages, remove the microphone from the speech board.

4.6.2 System Settings Affecting Speech Module Operations

The following Wash Select II system settings will have an effect on how the Speech Module operates.

Table 14. System Settings Affecting Speech Module Operations

Setting	Effect
Greeting Delay	This defines how long the Wash Select II should wait to play the greeting message for the first time after a customer has driven up.
Repeat Delay	This defines how long the Wash Select II should wait to play the greeting message again if customer activity has yet to begin. The greeting message will stop repeating once the customer initiates an action with the unit, such as adding money, selecting a wash or swiping a credit card.

4.7 Proximity Sensor

With the proximity sensor, the Wash Select II will detect vehicles when they drive up. The proximity sensor consists of the following components:

1. Transmitter/Receiver pair - attached to the door.
2. Power block - attached to the top of the power supply unit.

4.7.1 Normal Adjusting of Proximity Sensitivity

You may adjust the sensitivity of the proximity sensor by turning the control knob on the front of the power block. (See Figure 22.)

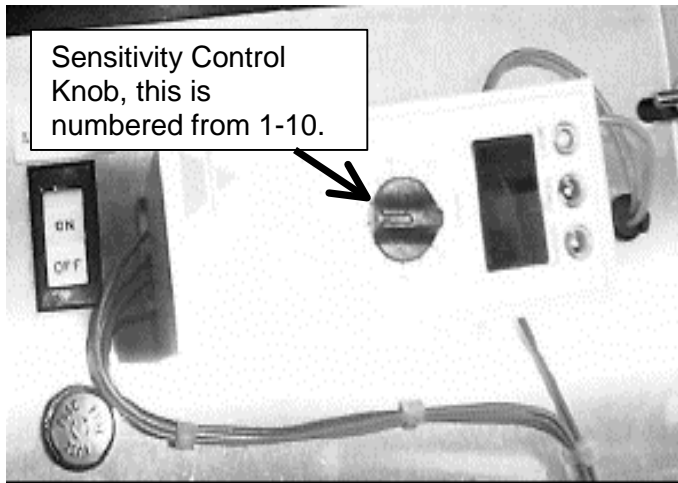

Figure 22. Proximity Sensor Power Block

You should test this adjustment with and without a vehicle in front of the unit. The normal sensitivity setting range is between 6 and 10 on the dial.

4.7.2 Adjusting Sensitivity with the 100% Range Setting

The proximity sensor block is shipped pre-set on the 25% range setting. If you find that this does not work for you, you may adjust the range setting on the power block. It is suggested that this adjustment be performed in bright sunlight. Follow the steps below to adjust the range setting.

1. Remove the power block from the Wash Select II.
2. Set the dial on the power block to the zero setting.
3. Using a small flat-head screwdriver, remove the small plastic cover below the dial on the power block.
4. Flip dipswitch 1 to the up position.
5. Replace the power block.
6. With no vehicle in front of the unit, turn the dial until the relay light (LED) comes on. You must always keep the dial below this setting.
7. Next, you must turn the dial toward the lower numbers until the relay light turns off and then turn the dial one more notch to the left.

It may be necessary to adjust the dial again at a later date if the proximity block "Relay" light comes on when there is no vehicle present. Too high of a gain setting will give a continuous false vehicle detection signal.

4.7.3 System Settings Affecting Proximity Sensor Operations

The following Wash Select II system settings will have an effect on how the Proximity Sensor operates.

Table 15. System Settings Affecting Proximity Sensor Operations

Setting	Effect
Greeting Delay	This defines how long the Wash Select II should wait to play the greeting message for the first time after a customer has driven up.
Repeat Delay	This defines how long the Wash Select II should wait to play the greeting message again if customer activity has yet to begin. The greeting message will stop repeating once the customer initiates an action with the unit, such as adding money, selecting a wash or swiping a credit card.

4.8 Coin Hopper and Assembly

The Wash Select II is equipped with a Suzo Mark II coin dispenser, which is embedded in a proprietary Unitec design. The dispenser is able to hold/dispense up to 2,400 quarter-sized coins. It is located inside the Wash Select II case directly behind the wash selection displays.

4.8.1 Filling the Hopper

The large opening at the top of the coin hopper has been added to increase the holding capacity of the dispenser. The inclined plane that spans across the top half of the hopper assembly is used to distribute the weight of the coins. When pouring coins into the dispenser, you must direct the coins at this inclined plane to protect the moving parts at the bottom of the hopper. Follow the instructions below to fill the coin hopper.

1. Open the door to the Wash Select II.
2. Pour the replacement coins into the large opening at the top of the hopper assembly. Remember to direct the coins toward the inclined plane.
3. When the coin level is close to 600 - 1200 coins, begin to add coins by hand. Using this method, coins will tend to slide into the dispensing wheel more easily, which will reduce to possibility of clogs and jams.

Time and experience should be your guide as to when to refill your hopper. Unitec recommends starting with approximately 900 coins to maintain a good accept/dispense ratio.

4.8.2 Removing the Hopper from the Wash Select II

To remove your hopper, follow the steps below.

1. Grasp the handle, located across the top of the hopper and pull the hopper up and out. Be careful not to accidentally jerk the wires out of the back of the hopper.
2. Once the wires at the back of the hopper are visible, grasp them at the brown plug housing and pull them straight back.
3. Gently rock the connector back and forth while pulling them outward until they have been disconnected from the hopper.

4.8.3 Cleaning and General Maintenance

The following maintenance should be performed on the Wash Select II every three months:

1. Remove the coin hopper from the unit.
2. Remove all coins from the hopper.
3. Use a damp rag to clean any metal dust that may have accumulated on the exit ramp.
4. Remove the two side screws that hold the bottom support bracket and pull the main hopper cube from the hopper assembly.
5. Use a Q-Tip or Iso-swab to clean the coin exit slot.
6. Remove the top part of the hopper by sliding the red lever on the side of the hopper downward. Slide the top part of the hopper upward to remove it.
7. Remove the hopper wheel and clean it with a damp rag.
8. Clean the inside of the hopper with a damp rag.
9. Reverse these steps to replace the hopper. Be sure you do not pinch the cable when returning the hopper into the Wash Select II case.

4.8.4 System Settings Affecting Coin Hopper Operations

The following Wash Select II system settings will have an effect on how the Coin Hopper and Assembly operate.

Table 16. System Settings Affecting Coin Hopper Operations

Setting	Effect
Dispense Mode	This will affect when a customer may receive change from the Wash Select II.
Dispense Value	This setting will configure the unit to know the monetary value of each coin dispensed.
Dump Coins	In the diagnostic mode, this setting can be used to dispense a specific number of coins for test.
Coins Present	Diagnostic function that detects the presence of coins in the hopper.
Exact Change Only	The Wash Select II will immediately go into an exact change only mode if it ever attempts to dispense change unsuccessfully. To clear this mode, turn the unit power off then on again. It will clear the next time it successfully dispenses change.

4.9 Card Reader

The card reader may be used with the Credit option or just for fleet cards and pass cards.

4.9.1 Card Reader Related System Settings

After repeated use, the credit card reader acceptance rate will begin to decline. This is due primarily to the internal sensing devices becoming soiled. It is best to clean your card reader using card reader cleaning cards. These cleaner cards may be purchased directly from your distributor or from the manufacturer of the cleaner cards. The cleaner cards are Unitec stock #MS2031 and can also be purchased from Clean Team by calling 1-800-888-8830.

4.9.2 System Settings Affecting Card Reader Operations

The following Wash Select II system settings will have an effect on how the Card Reader operates.

Table 17. Card Reader Related System Settings

Setting	Effect
Credit Mode 0 – no credit	The card reader will not recognize or try to process a transaction being made by any credit/debit cards, but it will process fleet and pass card accounts.
Credit Mode 1 – Demo mode	The card reader will log, process, and track all cards. All credit/debit cards are immediately “accepted” by the reader.
Credit Mode 2 – EDC mode	Normally, the card reader will only accept valid major credit cards, fleet cards, and pass cards. If the “Accept Propriety” setting is enabled, the reader will also accept proprietary credit/debit cards.
Credit Mode 3 – Generic Terminal mode	Same effect on the reader as Credit Mode 2.
Credit Mode 4 – POS Auth mode	The card reader will accept any credit/debit card swiped, as well as fleet cards and pass cards.
Credit Mode 5 – EDC Sheetz Mode	The card reader will accept any credit/debit card swiped, as well as fleet cards and pass cards.
Credit & Coupon	If this is disabled, the card reader will not accept card swipes that occur after a coupon code/card entry but before the purchase of a wash.
Allow Upgrades	If this is enabled and the credit mode is 4, the card reader will accept credit/debit card swipes that follow wash purchases, as long as an upgrade is available.

4.10 Thermal Printer Assembly

The printing operation involves the use of three different components. These components are the main CPU, the printer control board, and the print head mechanism. These components

are located in different positions throughout the Wash Select II. The following Sections contain information and procedures important for peak operating performance.

If you look towards the CPU, the section in the upper right hand corner just to the right of the setup/operate switch deals primarily with the printer. There you will find two push button switches mounted on the board labeled "Feed" and "Reset". You will find the printer control board mounted on the inside right wall of the Wash Select II case, just above the CPU board.

The following sections contain information and procedures important for peak operating performance.

1. Replacing the Printer Paper
2. Clearing a Paper Jam
3. Reset and Feed Buttons
4. Manually Printing a Self-Test

4.10.1 Replacing the Printer Paper

Replace printer paper when you see a red mark running down the side of the receipt or the unit is reporting Paper low.

1. Insert the new paper roll on the paper carriage at the bottom of the printer. The paper roll should be oriented such that the end of the paper is at the top of the roll. The paper will automatically feed into the printer when the power is on.
2. Close the rear door of the printer enclosure.

4.10.2 Clearing a Paper Jam

Follow the steps below to clear a paper jam.

1. Open the printer assembly.
2. Locate the blue locking arms on the sides of the printer assembly, pull them out and remove the main printer assembly by lifting it up and out.
3. Locate and remove the paper jam.
4. Once the jam has been dislodged, replace the main printer assembly and relock the blue locking arms.
5. Feed the paper into the slot marked "Paper Insert."
6. Test the printer.

4.10.3 Reset and Feed Buttons

If the printer ever malfunctions and does not respond to a request to print, you may need to either reset the control board, or print a self-test. Before these functions can be used, you will need to know where to find them. The reset and feed buttons are located at the top right hand side of the CPU board, to the right of the "Setup/operate" switch. The names are written

below each button. When the reset button is pressed, the printer control board and print mechanism will go through a forced system reset. This will clear up any failures due to electronic error. If you press the feed button and hold it, the paper feed motor will feed paper through the side of the Wash Select II door. The paper will stop feeding once you let go of the button.

4.10.4 Manually Printing a Self Test

If you ever question whether the system is functioning properly, you may have the system print a self-test page. This report is internally generated and will cycle through each available character. If the test prints completely and the printing is legible, this is considered a passed result.

To begin printing a self-test, press both the reset and feed buttons simultaneously for at least one second. After at least one second, let go of the reset button only, while continuing to hold down the feed button. The printer will begin to print a complete self-test.

4.10.5 Thermal Printer Control Board

The printer control board is the small circuit board located on the inside right wall of the Wash Select II case, just above the CPU. It controls data input and output, and communications traffic between the CPU and the printer head. If this component fails, the system will not operate. It is important, as with all internal components, that this component be protected from moisture and shock. If the printer is not working, make sure there is plenty of paper, make sure the feature is enabled in the software configuration and then run a unit self test. If the printer still does not operate properly, contact your distributor.

4.10.6 System Settings Affecting Thermal Printer

The following Wash Select II system settings will have an effect on how the Thermal Printer operates.

Table 18. System Settings Affecting Thermal Printer Operations

Setting	Effect
AUTO	Printer will detect presence of printer and use as needed; won't detect printer errors and page site operator.
Enable Receipt Printer	This function is found in the Misc. setup function menu. If the printer is disabled it will not be available for printing receipts for customer. This setting has no effect on report and accounting printing.

4.11 Fuse



Caution: For continued protection against risk of fire, replace only with same type and rating of fuse.

If you need to replace the fuse, be sure to replace it with only the same type and rating as the blown fuse.

Appendix A. Wash Select II – WashPay Notifications

WSII Pager ID	WSII Description	WashPay Alert ID	WashPay Alert
1	Hopper low	16	Peripheral low (10%)
2	Hopper empty	17	Peripheral empty
4	Wash out of service	4	Auto – Out Of Service
8	Printer paper	17	Peripheral empty
9	Printer power error	12	Peripheral error
10	Printer error	12	Peripheral error
11	Bill jam	13	Peripheral jammed
12	Bill stacker full	14	Peripheral full
13	Bill validator error	12	Peripheral error
14	Card reader error	12	Peripheral error
16	Wash fault	2	Fault -- Out Of Service
18	Wash in service	5	Auto – returned to service
20	Security alarm	25	Alarm activated

Appendix B. Circuit Board Connections

The following are pin out descriptions of the various connectors on the Wash Select II components:

CPU BOARD

J1 Main Power

Pin	Description
1	+5VDC main power input
2	GND for +5VDC main power input
3	+12VDC main power input
4	GND for +12VDC main power input

J21 Hopper

Pin	Description
1	Hopper Run – 12VDC when hopper is running
2	Hopper Run Ground
3	Coins present Feed
4	Coins present Return (short this to pin 3 when coins are present)
5	Coin Drop (short this to pin 2 when coin drops)
6	Not connected

J20 Proximity Input

Pin	Description
1	Proximity Feed +
2	Proximity Return (A short from this pin to pin 1 will activate proximity input)
3	N/C

J19 Fault/Warning Outputs

Pin	Description
1	Fault output Common (dry contact) 500ma max
2	Fault output Normally Open (dry contact) 500 ma max
3	Warning output Common (dry contact) 500 ma max
4	Warning output Normally Open (dry contact) 500ma max

J18 Wash Inputs

Pin	Description
1	Wash In Use Hot (20-120VAC/DC)
2	Wash In Use Neutral
3	Wash Fault Hot (20-120VAC/DC)
4	Wash Fault Neutral
5	Wash Warning Hot (20-120VAC/DC)
6	Wash Warning Neutral

J17 Wash Relays

Pin	Description
1	Program relay 1 output (500mA max)
2	Program relay 2 output (500mA max)
3	Program relay 3 output (500mA max)
4	Program relay 4 output (500mA max)
5	Program relay 5 output (500mA max)
6	Program relay 6 output (500mA max)
7	Program relay 7 output (500mA max)
8	Program relay 8 output (500mA max)
9	Program relay Common
10	N/C

J14 Misc Power Input

Pin	Description
1	5VDC Pass through power
2	GND for 5VDC Pass through power
3	24VAC Hot
4	24VAC Neutral
5	12VDC for I/O board
6	GND for 12VDC for I/O board

Note: J14 connects directly to J13 for power to bill validator and display I/O board.

J13 Misc Power to Display I/O board

Pin	Description
1	5VDC Pass through power for backlights
2	GND for 5VDC Pass through power backlights
3	24VAC Hot
4	24VAC Neutral
5	12VDC for I/O board
6	GND for 12VDC for I/O board

J9 Bill Validator (MDB Mode)

Note to Unitec Technicians: The following pin outs are reversed from the schematic to match the pin numbering embossed in the MDB housing. Pin 1 on the housing equates to Pin 8 on Unitec internal schematics.

Pin	Description
1	Not Connected
2	Not Connected
3	Signal Ground
4	MDB Tx
5	MDB Rx
6	Not Connected
7	24VDC Power
8	24VDC Power

J12 Bill Validator (Pulse Mode)

Pin	Description
1	Bill Enable Common (N/C) (voltage applied to J11 pin 2) Normally 24AC neutral (Note: 12VDC for Canadian units)
2	Bill Enable switched (switched voltage applied to J11 pin 1) Normally 24AC hot (Note: 12VDC for Canadian units)
3	Not connected
4	Bill pulse 1 (not used)
5	Bill pulse 0 (\$1 credit pulse) Short to pin 6 to issue bill pulse – floats at 12VDC normally.
6	Bill pulse common (GND of 12VDC)
7	Bill power Neutral (Voltage applied to J11 pin 2) Normally 24AC neutral (Note: 12VDC for Canadian units)
8	Bill power Hot (Voltage applied to J11 pin 1) Normally 24AC Hot (Note: 12VDC for Canadian units)

J11 Bill Validator Power Input

Pin	Description
1	Bill validator Power Hot – Normally 24AC Hot
2	Bill validator Power Neutral – Normally 24AC Neutral
3	N/C

J10 Speaker

Pin	Description
1	Speaker Output +
2	Speaker Output -
3	Intercom input + (when no speech is playing this is tied to pin 1)
4	Intercom input – (when no speech is playing this is tied to pin 2)

J5 Printer Control Board Power (Printer Option Only)

Pin	Description
1	24VDC + output (from J4 pin 1)
2	24VDC + output (from J4 pin 1)
3	24VDC ground output (from J4 pin 2)
4	24VDC ground output (from J4 pin 2)
5	5VDC ground output (from J1 pin 2)

6	5VDC + output (from J1 pin 1)
---	-------------------------------

J4 24VDC Printer Power (Printer Option Only)

Pin	Description
1	24VDC + input from power supply
2	24VDC ground input from power supply

P1 Modem Connection (Standard PC-AT Pin Outs)

Pin	Description
1	CD – carrier detect input
2	Receive Data input
3	Transmit Data output
4	DTR – Data terminal ready output
5	Ground
6	DSR – input
7	RTS – request to send output
8	CTS – clear to send output
9	N/C

J22 Expansion RS-485 Half Duplex (POS4000 Interface)

Pin	Description
1	RS485 – (To POS4000 Pin 1)
2	RS485 + (To POS4000 Pin 2)
3	Ground reference (optically isolated) (To POS4000 Pin 3)

J23 Future Expansion RS-232

Pin	Description
1	Not defined at this time
2	Not defined at this time
3	Not defined at this time
4	Not defined at this time
5	Not defined at this time
6	Not defined at this time
7	Not defined at this time
8	Not defined at this time
9	Not defined at this time

J26 Data to Display I/O Board

Pin	Description
1	Encoded Button 0
2	GND
3	Encoded Button 1
4	Display DB0
5	Encoded Button 2
6	Display DB1
7	TTL Cash Enable
8	Display DB2
9	5VDC
10	Display DB3
11	TTL Coin pulse 1
12	Display DB4
13	TTL Coin pulse 2
14	Display DB5
15	TTL Coin pulse 3
16	Display DB6
17	TTL Coin pulse 4
18	Display DB7
19	N/C
20	GND
21	5VDC
22	Display RS
23	Keypad Feed 0
24	Display R/W
25	Keypad Feed 1
26	Display Enable 0
27	Keypad Feed 2
28	Display Enable 1
29	Keypad Return 0
30	Display Enable 2
31	Keypad Return 1
32	GND
33	Keypad Return 2
34	Keypad Return 3

J25 Display I/O Board Data

Pin	Description
1	N/C
2	Rear Sensor
3	Card Present
4	Data Track 1
5	Wash Fault TTL for LED
6	Strobe Track 1
7	Aux output 4
8	Data Track 2
9	Aux output 3
10	Strobe Track 2
11	Aux output 2
12	Wash Relay 1 TTL
13	Aux output 1
14	Wash Relay 2 TTL
15	Aux input 2
16	Wash Relay 3 TTL
17	Aux input 1
18	Wash Relay 4 TTL
19	Bill Pulse 0 TTL (\$1 credit pulse)
20	Wash Relay 5 TTL
21	Wash Warning output TTL for LED
22	Wash Relay 6 TTL
23	Wash Warning input TTL for LED
24	Wash Relay 7 TTL
25	Wash in use input TTL for LED
26	Wash Relay 8 TTL

DISPLAY I/O BOARD

J3 Main Coin Acceptor

Pin	Description
1	24 AC Hot Switched (500 mA average max)
2	24 AC neutral
3	24 AC neutral
4	Coin 1 pulse (short to pin 3 or pin 2 for coin pulse)
5	Coin 2 pulse (short to pin 3 or pin 2 for coin pulse)
6	Coin 3 pulse (short to pin 3 or pin 2 for coin pulse)

J2 Auxiliary Coin Acceptor

Pin	Description
1	24 AC Hot Switched (500 mA average max)
2	24 AC neutral
3	24 AC neutral
4	Coin 4 pulse (short to pin 3 or pin 2 for coin pulse)

J1 Main Power Input

Pin	Description
1	5VDC power for backlights
2	GND for 5VDC power backlights
3	24VAC Hot
4	24VAC Neutral
5	12VDC for diverter solenoid
6	GND for 12VDC for diverter solenoid

JP1 Ribbon Cable Coin Acceptor Interface

Pin	Description
1	12VDC switched (500 mA average max)
2	GND for 12VDC
3	Coin 4 (sink to pin 2 for coin input)
4	Coin 3 (sink to pin 2 for coin input)
5	N/C
6	N/C
7	Coin 2 (sink to pin 2 for coin input)
8	N/C
9	Coin 1 (sink to pin 2 for coin input)
10	N/C
11	N/C
12	N/C
13	N/C
14	N/C
15	N/C
16	GND for 12VDC

J25 Diverter Solenoid Output

Pin	Description
1	12VDC + solenoid fire output
2	Ground 12VDC for solenoid output
3	N/C

J9 Credit Card Reader

Pin	Description
1	Rear Sensor
2	Data Track 2
3	Card Present
4	Strobe Track 2
5	N/C
6	5VDC power to card reader
7	GND power to card reader
8	Strobe Track 1
9	Data Track 1

J20 Wash 1 Button

Pin	Description
1	12VDC button feed (current limited)
2	Button return (short this to Pin 1 for button press)

J21 Wash 2 Button

Pin	Description
1	12VDC button feed (current limited)
2	Button return (short this to Pin 1 for button press)

J22 Wash 3 Button

Pin	Description
1	12VDC button feed (current limited)
2	Button return (short this to Pin 1 for button press)

J23 Wash 4 Button

Pin	Description
1	12VDC button feed (current limited)
2	Button return (short this to Pin 1 for button press)

J24 Refund Button

Pin	Description
1	12VDC button feed (current limited)
2	Button return (short this to Pin 1 for button press)

J5 Keypad Connector

Pin	Description
1	Return 2 (row 4, 5, 6)
2	Return 1 (row 7, 8, 9)
3	Feed 2 (column 3, 6, 9, #)
4	Return 0 (row *, 0, #)
5	Feed 0 (column 1, 4, 7, *)
6	Return 3 (row 1, 2, 3)
7	Feed 1 (column 2, 5, 8, 0)
8	N/C

J23 Backlight for Main Display

Pin	Description
1	Backlight Ground – (black)
2	Backlight Power + (Red)

J19 Backlight for Wash Display 1

Pin	Description
1	Backlight Ground – (black)
2	Backlight Power + (Red)

J17 Backlight for Wash Display 2

Pin	Description
1	Backlight Ground – (black)
2	Backlight Power + (Red)

J15 Backlight for Wash Display 3

Pin	Description
1	Backlight Ground – (black)
2	Backlight Power + (Red)

J12 Backlight for Wash Display 4

Pin	Description
1	Backlight Ground – (black)
2	Backlight Power + (Red)

J11 Main Display

Pin	Description
1	5VDC Ground
2	5VDC power
3	Ground (contrast)
4	RS
5	R/W
6	Enable 0
7	DB0
8	DB1
9	DB2
10	DB3
11	DB4
12	DB5
13	DB6
14	DB7

J6 External Fleet Connector

Pin	Description
1	5VDC power
2	Aux Output 1
3	Aux Output 2
4	Aux Input 2
5	12VDC power

J7 External Fleet Connector

Pin	Description
1	GND
2	Aux output 3
3	Aux output 4
4	Aux input 1
5	GND for 12VDC power

EXPANSION BOARD

J5 CPU Board Connector

Pin	Description
1	VCC
2	Address pin 0
3	VCC
4	Address pin 1
5	N/C
6	Address pin 2
7	/RES
8	Address pin 3
9	RES
10	Address pin 4
11	/RD
12	Address pin 5
13	/WR
14	Address pin 6
15	A2
16	Address pin 7
17	A1
18	INTE input
19	A0
20	INTF input
21	/EXPANSION input
22	INTG input
23	/UARTG input
24	INTH input
25	/UARTH input
26	/PCS4 input
27	Ground 12V DC hopper input
28	/PCS5 input
29	Ground 12V DC hopper input
30	N/C
31	12V DC hopper output
32	Ground
33	12V DC hopper output
34	Ground

P2 Debit

Pin	Description
1	RS485
2	RS485
3	VCC
4	Ground

P4 Spare 232/485

Pin	Description
1	N/C
2	RX 232
3	TX 232
4	DTR 232
5	Ground
6	DSR 232
7	N/C
8	N/C
9	N/C

Appendix C. Tunnel Mode

Please refer to Section 2.5.8 before proceeding.

The following describes what default configurations are required to set the coin box into tunnel mode:

Setting up tunnel mode with Start key (Accepts Cash):

1. Using the Wash Interface menu; set tunnel mode to '1'.
2. The Wash Select II must be set as follows:
 - Wash Upgrade = Disabled (Default Value)
 - Relay Stacking = Enabled (Default Value)
 - Relay Latching = Pulsed (Default Value)
 - Forced Selection = Enabled (Default Value)

TYPICAL CUSTOMER TRANSACTION IN TUNNEL MODE:

Customer drives up to Wash Select II, which then after several seconds of having the proximity sensor activated, plays a greeting message.

Customer enters some form of money. The Wash Select II plays a wash selection message (messages 3-6). Included at the end of the wash selection message the message should be recorded to say "... Please press the start button to begin your wash."

This message will be repeated every 30 seconds until the Start Button is pressed.

The Wash Select II generates no signals at this time (relays P1-P8 are open).

The customer presses the "Start" button.

Message 12 plays. During setup, it should be recorded to play: "Please place your car in neutral, roll up your windows and wait for the conveyer to start your wash" (note: you can change or re-record this message if needed).

After pressing the Start button, the programmed output relays are activated momentarily (pulsed on for 8 – 10 seconds, then off). The customer screen is then reset to the "Idle Greeting" screen after 20 seconds.

[THIS PAGE INTENTIONALLY LEFT BLANK]

Appendix D. Wash Select II/POS4000 Canadian Addendum

This Appendix provides additional information relevant to Canadian Wash Select II units.

A. Configure the Wash Select II Coin Dispenser

Remember that the coin that is dispensed is the one that is diverted by the coin acceptor, and ends up in the hopper.

1. To dispense the \$1 coin:

1. From the SETUP menu, go to “CASH & TOKENS”, and then select “COUNTRY CODE”.
2. Set COUNTRY CODE to ‘2’.
3. From the “cash & tokens” menu, select DISPENSE VALUE and set it to \$1.

2. To dispense Quarters:

1. From the SETUP menu, go to “CASH & TOKENS” and select “COUNTRY CODE”.
2. Set COUNTRY CODE to ‘1’.

B. Token Setup

You can have up to three different types of site-specific tokens. Unitec sends the coin-acceptor programmed to accept the Canadian \$1 coin, \$2 coin and quarters. Programming the unit to take tokens is up to the site, as every site has its own tokens.

For more tokens, your token values should be an integer-multiple of the lowest-value token. For example, if your lowest-value token is \$1, your second and third token values should be one of \$2, \$3, \$4, etc. Of course, you wouldn’t program two tokens to have the same value.

You have the option of limiting the number of tokens a customer can use per car wash purchase; you can do so from the “cash & tokens” menu in the setup mode by setting “max tokens/cust” to any number you want.

The Wash Select II does not keep an account of the different types of tokens your site may have; we just show the total value of all the tokens on the accounting report.

C. Disable Quarter Acceptance

To disable the acceptance of quarters:

**Note:**

You can do this only for the standard Canadian Wash Select II (accepts all quarters, \$1 and \$2 coins, and tokens).

1. Remove the coin acceptor label that reads “Quarters, \$1 & \$2 coins, Tokens” from the front of the door.

2. Attach the new label that reads "\$1 coin, \$2 coin, Token".
3. Put the unit in setup mode.
4. Go to the Diagnostics main menu.
5. Go to the "Test bills/coins" sub-menu.
6. Open the cover of the IDX acceptor.
7. Turn the rotary switch of the IDX to position 5.
8. Press the reset button to the left of the rotary switch only once.
9. Turn the rotary switch back to zero and close the IDX cover.
10. Insert quarters to the IDX to check if the quarter acceptance has been erased from the IDX.

D. Programming the IDX to Accept Currency

The Canadian Wash Select II comes programmed to accept and dispense the Canadian \$1 dollar coin and quarter. If your unit needs to be reprogrammed for any reason, use the following procedures.

To program the IDX acceptor, you will need to have six of each of the coins that you are trying to program (coins or tokens).

1. If you are accepting old style \$1 coins:

11. Remove the front cover by pushing in and up at the bottom right corner of the main body of the unit (near the phone number printed on the cover).
12. Find the rotary-switch and set it to the position labeled number 5.
13. Press the reset button immediately to the left of the rotary switch once.
14. Drop the six different old style dollar coins through the acceptor. The IDX will blink once after each coin. Verify that the light (LED) blinks 5 times after the last coin is entered.
15. Replace the rotary switch back to zero.

2. If you are accepting new style \$1 coins:

1. Remove the front cover by pushing in and up at the bottom right corner of the main body of the unit (near the phone number printed on the cover).
2. Find the rotary-switch and set it to the position labeled number 4.
3. Press the reset button immediately to the left of the rotary switch once.
4. Drop the six different new style dollar coins through the acceptor. The IDX will blink once after each coin. Verify that the light (LED) blinks 5 times after the last coin is entered.
5. Replace the rotary switch back to zero.

3. If you are accepting quarters:

1. Remove the front cover by pushing in and up at the bottom right corner of the main body of the unit (near the phone number printed on the cover).
2. Find the rotary-switch and set it to the position labeled number 6.

3. Press the button immediately to the left of the rotary switch once.
4. Drop the 6 quarters through the acceptor. The IDX will blink once after each coin. Verify that the light (LED) blinks 5 times after the last coin is entered.
5. Replace the rotary switch back to zero.

4. If you are accepting old \$2 coins:

6. Remove the front cover by pushing in and up at the bottom right corner of the main body of the unit (near the phone number printed on the cover).
7. Find the rotary-switch and set it to the position labeled number 3.
8. Press the button immediately to the left of the rotary switch **eight** times.
9. Drop the six different new style 2 dollar coins through the acceptor. The IDX will blink once after each coin. Verify that the light (LED) blinks 5 times after the last coin is entered.
10. Replace the rotary switch back to zero.

5. If you are accepting new \$2 coins:

1. Remove the front cover by pushing in and up at the bottom right corner of the main body of the unit (near the phone number printed on the cover).
2. Find the rotary-switch and set it to the position labeled number 2.
3. Press the button immediately to the left of the rotary switch **eight** times.
4. Drop the six different new style 2 dollar coins through the acceptor. The IDX will blink once after each coin. Verify that the light (LED) blinks 5 times after the last coin is entered.
5. Replace the rotary switch back to zero.

6. If you are accepting site-specific tokens:

See Token Setup above for more information.

1. Find the rotary-switch and set it to the position labeled number 1, 2 or 3.
2. Press the button immediately to the left of the rotary switch once (or more for a different number of pulses).
3. Drop the six sample tokens through the acceptor, and verify that the light (LED) blinks multiple times after the last coin is entered.
4. Reset the rotary switch to 0 and replace the front cover.

a) To program the IDX to accept two different types of tokens, token 1 for \$1 and token 2 for \$2:

1. Set the rotary switch to position 1
2. Press the button to the immediate left once
3. Drop the six sample tokens and note that the LED blinks multiple times after the last token
4. Set the rotary switch to position 2
5. Press the button twice (for 2 pulses or \$2)

6. Drop the six sample tokens of the second type, and note that the LED blinks multiple times after the last token
7. Replace the rotary switch to 0
8. Replace the cover

Refer to the following table for your token information.

Table 19. Wash Select II Token Values

Name		Default setting	Maximum Allowed
Token Value		\$1.00	\$99.00
Maximum Transaction	Tokens per	80	80



Note:

The IDX coin-acceptor can be programmed to divert either the \$1 coin or a quarter. The diverted coin needs to be programmed to be on pin 6 of the IDX always.

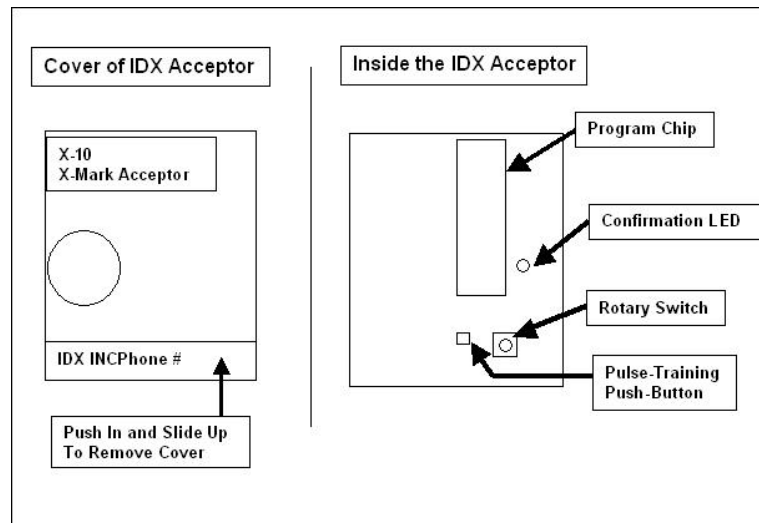



Figure 23. Outside/Inside the IDX Coin Acceptor

The table below lists the programming structure.

Table 20. Canadian IDX Program Configuration

IDX Rotary Switch Position	Old Style with \$1 coin Diverted	New Style with \$1 Coin Diverted	Number of Output Pulses	
			Old Style \$1 coin diverted	New Style \$1 Coin Diverted
1	Token 1	Token 1	1-12, 14-255	
2	Token 2	\$2 Coin	1-255	8 on Coin 2
3	Token 3	\$2 Coin	1-255	8 on Coin 2
4	\$2 coin	\$1 coin	8	1 on Coin 1
5	Quarters	\$1 Coin	1	1 on Coin 1
6	\$1 Coin	Quarters	1	1 on Coin 2

	<p>Note: If you wish to dispense quarters instead, you will also need to disassemble the hopper and change the wheel and guide-arm. (This is in addition to having to reprogram the IDX). The quarter wheel and guide arm are shipped with your unit. For instructions on how to do this, see Section 4.5.5 of the Operation manual.</p>
---	---

E. Credit setup

If you have the credit option w/modem, you must decide whether you would like to do batch closing and opening manually or automatically. Manual batch opening and closing gives you the option of closing and opening batches at your own convenience, while in auto batch opening and closing, the machine does it all automatically. In auto mode, batch closing/opening happens once every 24 hours at 11pm every night. If you shut your machine down before 11 pm every night, the batch closing/opening happens the next morning when you turn the machine back on again. If, on the other hand, you do not turn the machine off, but instead use either the WIU or Fault inputs to generate an “Out of Service” condition overnight, the machine will close/open batches regardless at 11pm.

1. To Manually Open/Close Batch:

1. Go to the setup menu, by turning the setup/operate switch to setup.
2. Go to “Misc. setup” main menu.
3. Select the “system time” sub menu and set the time to your current standard time.
4. Then go to the “credit systems” main menu.
5. Go to the “credit systems” main menu in setup mode.
6. Select “open batch”; batch should open. If batch opens, skip to step 13 below.
7. If batch doesn’t open, cycle power to the entry stand, and try to repeat the batch opening process.
8. If you are still having problems, check if the modem is powered. Also, check if the modem cable is well connected. Then, repeat the process.

9. If you are still having problems, go to the Diagnostics main menu, and choose “test modem” command. If the modem responds with an OK message, try to open a batch again.
10. If you are unable to do so at this point, then you might have a modem with the wrong programming. If you have the printer option, then go the “credit systems” menu, and choose “print trans hist” command. Check the printout to see the reason of the failure.
11. If you have any clues from the printout, proceed to open the batch after solving the problems.
12. If you are still experiencing problems, modem might be bad.
13. When it is time for you to close a batch (which must be after some transactions by your customers), go to setup mode. From the setup mode, select “credit systems”. Then choose “close batch”. Batch should close.
14. After closing a batch, you should open another batch for your next business cycle.

2. To Automatically Open/Close Batch:

1. Go to the setup menu, by turning the setup/operate switch to setup.
2. Go to “Misc. setup” main menu.
3. Select the “system time” sub menu and set the time to the current standard time.
4. From the setup menu, go to the “Credit systems” main menu.
5. Select “processor type” and set it to 1.
6. From the Credit Menu, select Set Autobatch and enable it.
7. Go to the “open batch” command under “Credit systems”.
8. Batch should open. If so, skip to step 15.
9. If batch doesn’t open, cycle power to the entry stand, and try to repeat the batch opening process.
10. If you are still having problems, check if the modem is powered. Also, check if the modem cable is well connected. Then, repeat the process.
11. If you are still having problems, go to the Diagnostics main menu, and choose “test modem” command. If the modem responds with an OK message, try to open a batch again.
12. If you are unable to do so at this point, then you might have a modem with the wrong programming. If you have the printer option, then go the “credit systems” menu, and choose “print trans hist” command. Check the printout to see the reason of the failure.
13. If you have any clues from the printout, proceed to open the batch after solving the problems.
14. If you are still experiencing problems, please contact Unitec, as your modem might be bad.
15. You are now ready to do business via credit. You can return the unit back to operate mode via the setup/operate switch.
16. If you, for any reason, change your mind to resort to manual batch opening/closing, all you have to do is repeat steps 5 and 6 above, setting

“processor type” to zero and disabling Autobatch. In addition, do the procedures found under “If you want to do batch opening/closing manually” above.

F. CashCode Bill Validator

The Canadian Wash Select II comes equipped with the CashCode bill validator.

1. Emptying the Bill Stacker

The CashCode bill stacker will hold up to 400 bills and is equipped with a keyed-entry vault.

To empty the bill stacker, squeeze the release levers located on both sides of the bill stacker while pulling it back. Lift the bill stacker up and back to remove it from the bill validator. You will need a key (included with the CashCode bill validator) to open the stacker and remove the bills.

2. Replacing the Stacker

To replace the bill stacker, slide the base of the stacker into the mount guides. Press the stacker forward until it snaps into place.

3. Flash Codes*

The diagnostic LED on the CashCode bill validator is located on the front of the unit. If it is lit, it indicates there is a problem. If the red light on the front of the bill validator is ON insert bill and remove it after the red light goes OFF. Count the number of flashes and compare with the diagnostic chart below.

Table 21. CashCode Bill Validator Diagnostic Flash Codes

#	Description	#	Description
1	Cassette is removed from bill validator	7	Failure of magnetic sensors
2	Stacking motor does not rotate	8	Transport motor does not move
3	Cassette is full	9	Speed of transport motor is too high
4	Mechanical jam in the cassette	10	Transport motor electrical overload
5	Stacking motor electrical overload	11	Bill pathway security latch is open

*Taken from the CashCode® Model AMZ-USA-MDB-UNV User's Guide

#	Description	#	Description
6	Failure of optical sensors	12	Banknote is in the entry slot of the cassette and credit is not issued

4. Removing the CashCode from the Wash Select II

Follow the steps below to remove the bill validator.

1. Hold the Bill Validator at the top.
2. Remove the two Phillips head screws on the left side of the Bill Validator faceplate.
3. Remove the two Phillips head screws from the bottom of the Bill Validator faceplate. (Be careful not to yank, tear, or rip out the wires connected to the Bill Validator).
4. Once the wires on the right side of the Bill Validator are in view, grasp them at the connector and disconnect them by gently rocking them back and forth.

5. Cleaning and General Maintenance

To clean the CashCode bill validator, first remove it from the Wash Select II using the above procedure. Next, turn the validator face down. Push the button labeled "PUSH." When you do, the lower housing will open and reveal the sensors. Use an alcohol swab to clean the heads and remove any visible debris. Fold up the bottom part of the lower housing. Press the top part of the housing cover down until it latches shut.

6. Programming the CashCode Validator

The CashCode bill validator is programmed using the DIP switches located on the controller board. To access these switches, remove the controller board cover plate by following the instructions on the label. When you have located the DIP switches, refer to the following image for the appropriate settings.

Table 22. CashCode DIP Switch Settings*

US5B	1	2	3	4	5	6	7	8	SWITCHES
ON  OFF	1P/\$1	ENABLE					ON	ON	HII
	\$1	\$2	\$5	\$10	\$20	ON	OFF	SP Fast	
	4P/\$1	DISABLE					OFF	ON	SP Slow
							OFF	OFF	MDB

* Taken from the CashCode® Model AMZ-USA-MDB-UNV User's Guide

[THIS PAGE INTENTIONALLY LEFT BLANK]

Appendix E. Security Alarm Option

The Security Alarm option adds an alarm to the WSII that monitors the door for unauthorized entry, and a shock sensor for detecting attempted vandalism or break-ins. When triggered, a siren will sound from 1-60 minutes, a message will display and print on the primary POS4000 controller, and a page will be sent if you have paging configured.

**Note:**

The siren will not go off if the unit is in Setup mode, even when the alarm is armed and triggered.

A. Arming and Disarming the Alarm

When the alarm is armed, any attempt to open the door will trigger the siren. In order to open the door without setting off the alarm, you will need to setup a pass code or pass card that arms and disarms the alarm. Then when you wish to open the door, swipe the card or enter the code, and select "Disarm". When you have closed the door, swipe the card or enter the code again and select "Arm".

Use the following procedures to setup your Security Alarm pass code or pass card.

**Note:**

All code numbers must end with a zero. If the number or card you enter already exists, the Wash Select II will prompt you to enter another number. Follow the steps below to program a Pass Code or Pass Card.

1. Using the toggle switch at the top of the CPU board, place the Wash Select II in setup mode by moving the switch toward the back of the Wash Select II case. (The CPU board is located on the inside right wall of the Wash Select II case.)
2. Using the (3) key to scroll forward and the (1) key to scroll back, scroll through the main menu until the "Pass Code/Card" option is displayed. Press the (*) key to enter.
3. Scroll through this menu until the "Add Code/Card" option is displayed, and then press the (*) key to enter. (This should be the first option displayed.)

The following table will show you how to program a code and a card. The first three steps above are the same for programming each.

Table 23. Programming Pass Codes/Cards

PASS CODE	PASS CARD
<ol style="list-style-type: none"> 1. Press the (1) key for code. 2. Enter the code number, and then press the (*) key to enter. (The code must be at least four digits long and end with a zero.) 3. Using the (3) key to scroll, scroll forward until you find the menu option you are programming the code to access. 	<ol style="list-style-type: none"> 1. Press the (3) key for card. 2. Insert the card into the card reader or key in the number that appears on the front of the card, and then press the (*) key to enter. (If you insert the card there is no need to press the (*) key.) 3. Using the (3) key to scroll, scroll forward until you find the menu option you are programming the code to access.

B. Configuring the Alarm Duration

The Security Alarm option allows you to set the length of time that the alarm's siren will sound using this command. To set the alarm duration:

1. Using the toggle switch at the top of the CPU board, place the Wash Select II in setup mode by moving the switch toward the back of the Wash Select II case. (The CPU board is located on the inside right wall of the Wash Select II case.)
2. Using the (3) key on the Wash Select II keypad to scroll forward, (the (1) key scrolls backward) scroll through the "Main Menu" until "Misc. Setup" is displayed.
3. Press the (*) key to enter.
4. Using the (3) key on the Wash Select II keypad to scroll forward, (the (1) key scrolls backward) scroll through the menu until "Alarm Duration" is displayed. Press the (*) key to enter.
5. Enter the length of time you want the alarm to sound in minutes (from 1-60) and press the (*) key.
6. **Default: 5 minutes**

C. Security Alarm Option Hardware

The Security Alarm option consists of a Shock Sensor, the Alarm Siren, and the Door Switch.

1. Shock Sensor

The shock sensor is mounted on the inside of the door beside the coin acceptor. This position allows the shock sensor to respond to the severe jarring of the door usually associated with vandalism or attempted theft.

The shock sensor is wired to phoenix connector J12, pins 3 & 6 on the CPU board.



Figure 24. Shock Sensor

2. Alarm Siren

The alarm siren is mounted to the rear-left corner of the Wash Select II case. When triggered, this provides maximum decibel magnification as the sound waves reverberate off the stainless steel.

The siren is wired to J19 pins 3 & 4 on the CPU board.

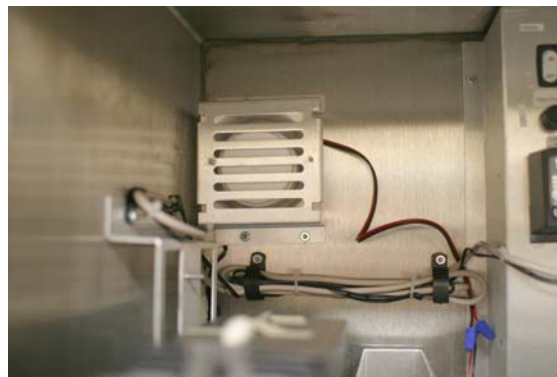

Figure 25. Mounted Siren

3. Door Switch

The door switch detects whether the door is open or closed. When the alarm is armed, opening the door will set off the siren.

The door switch is connected to J18, pins 3 & 4 of the CPU Board.



Figure 26. Door Switch

4. Wiring Information

Refer to the following table and diagram for wiring the siren to the WS2 CPU board.

Table 24. Wiring Guide

From	To
Siren, Black Wire	CPU Board J1, Pin 4
Siren, Red Wire	CPU Board J19, Pin 4
CPU Board J1, Pin 3	CPU Board J19, Pin 3
Door Switch COM (White Wire)	CPU Board J18, Pin 6
Door Switch NO (Orange Wire)	CPU Board J11, Pin 2
CPU Board J18, Pin 5 (Blue Wire)	CPU Board J11, Pin1
Shock Sensor (either wire)	CPU Board J12, Pin 3
Shock Sensor (either wire)	CPU Board J12, Pin 6

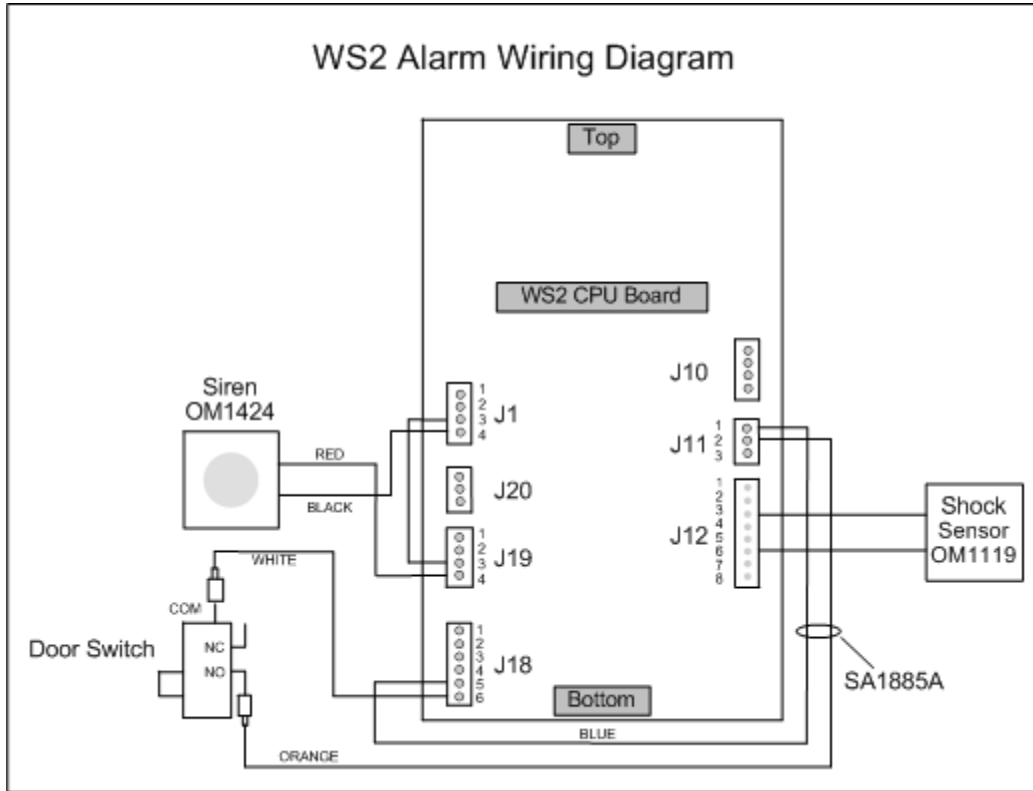

Figure 27. WS2 Alarm Wiring Diagram

[THIS PAGE INTENTIONALLY LEFT BLANK]

Appendix F. Citizen CD-S500 Printer Configuration Procedures

Refer to the Citizen CD-S500 operations manual, page 36 for more information on configuring the printer.

Configuration Settings	
Command Type	CBM2
Number of Col.	42/35
Font Select	7*9

To configure the printer for operation with the POS4000, perform the following procedure:

1. With the front cover open, turn power on while pressing the FEED button; then release the FEED button.
2. The POWER LED will flash as the printer enters the maintenance mode; close the front cover.
3. Press the FEED button until you hear a single beep; reopen and close the front cover.
4. Press the FEED button until you hear a single beep and release it. The printer will print the setting for COMMAND TYPE. Continue to press the FEED button until the printer prints "Command Type -CBM2".
5. Press and hold the FEED button until you hear a single beep followed by three quick beeps.
6. Press the FEED button until you hear a single beep and release it. The printer will print the setting for NUMBER OF COL. Continue to press the button until the printer prints "Number of Col. -42/35".
7. Press and hold the FEED button until you hear a single beep followed by three quick beeps.
8. Press the FEED button until you hear a single beep and release it. The printer will print the setting for FONT SELECT. Continue to press the button until the printer prints "Font Select -7*9".
9. To save the configuration, open and close the front cover.