

POS4000/V2-Wash Select II

Operations Manual

SOFTWARE VERSION
POS4000 8.25



Unitec

www.StartwithUnitec.com

443-561-1200



POS4000/V2-WASH SELECT II

OPERATIONS MANUAL

SOFTWARE VERSION 8.25

This document provides comprehensive operational procedures for the POS4000 Carwash Marketing System. In this manual, we will discuss the installation and operations of the POS4000, along with cashier and management operations.

If further assistance is needed, please contact the distributor from which the product was purchased.

When calling for assistance, you must have the following information available:

POS4000 Serial Number: _____

Distributor Name: _____

COPYRIGHT

© 2010 Unitec, Incorporated. All rights reserved. No part of this book, including text, screen examples, diagrams, or icons, may be reproduced or transmitted in any form, by any means (electronic, photocopying, recording, or otherwise) without prior written permission of Unitec, Incorporated.

TRADEMARKS

Wash Select II, POS4000, Unitec, and the Unitec Logo are trademarks, service marks, or registered trademarks of Unitec, Incorporated.

All other products, services, and company names are trademarks or registered trademarks of their respective owners.

Table of Contents

Quick Start Guide	1
Quick Reference Guide	1
1 Overview	1
1.1 Keypad Layout.....	2
1.2 Wash Select II POS System.....	3
2 Installation	7
2.1 Pre-Installation Requirements.....	7
2.2 Wiring.....	8
2.2.1 Wiring Information for POS4000 Interface Board.....	9
2.3 POS4000 Function Lines/Car Wash Features.....	11
2.4 Installing/Upgrading the EPROM Chip.....	12
3 Testing	15
3.1 Console Testing.....	15
3.2 Interface Board Testing.....	15
3.2.1 Relay Test.....	17
3.2.2 Input Test.....	17
3.2.3 Keypad Test.....	18
4 Management Control (Command Reference)	21
4.1 System Configuration.....	22
4.1.1 Set System Time and Date.....	24
4.1.2 Configuring a Group.....	24
4.1.3 Set Code Age Warning.....	25
4.1.4 Set Code Length.....	26
4.1.5 Disable Cashier Keys.....	26
4.1.6 Set Serial Baud Rate.....	27
4.1.7 Set Languages.....	28
4.1.8 Set Program Relays.....	28
4.1.9 Cash Upgrades (Options) Menu.....	29
4.1.10 External POS MENU->.....	31
4.1.11 Multiple Unit MENU->.....	36
4.1.12 Modem rings.....	38
4.1.13 E-System setup MENU->.....	38
4.1.14 Relay Latching.....	39
4.1.15 Relay Stacking.....	39

4.2	Multi-Use Codes	40
4.2.1	Requirements and Limitations.....	40
4.2.2	Template Programming On the POS4000	40
4.2.3	Selling a Multi-use Code on the External POS.....	41
4.3	Fleet Account Management.....	41
4.3.1	Print Current Information of All Accounts	42
4.3.2	Add an Account.....	42
4.3.3	Delete an Account.....	44
4.3.4	Print Information on a Specific Account	44
4.3.5	Reset Number of Washes for an Existing Account.....	44
4.3.6	Delete Empty Accounts.....	45
4.4	Accounting Report	45
4.4.1	POS4000 Accounting Report	45
4.4.2	POS4000-WSII Accounting Report	49
4.4.3	Print Accounting Report	54
4.5	Set Prices.....	54
4.5.1	Set Regular or Discount Prices	55
4.5.2	Print Pricing Report.....	56
4.5.3	Set Tax Rate	56
4.5.4	Enable TAX Round Off.....	56
4.6	Service Routines.....	57
4.6.1	System Configuration Report	57
4.6.2	Link Test	57
4.6.3	LED Test.....	58
4.6.4	Set Print To display (Non printer Mode)	59
4.6.5	Display POS Diags.....	59
4.7	Clear Audit Counts.....	59
4.8	Set Messages	60
4.8.1	Change Header Message	60
4.8.2	Change Postscript 1-5.....	61
4.8.3	Change Footer Message.....	62
4.8.4	Change Coinbox Messages (E-System 4000 Only).....	62
4.8.5	Print Current Message Configuration	63
4.9	Set Passwords.....	63
4.9.1	Change a Specific Password	63
4.10	Void a Code	64
4.11	Memory Information	64
4.11.1	Print Valid Codes	65
4.11.2	Print Used Codes.....	65

4.11.3	Clear ALL Valid Codes	65
4.11.4	Clear ALL Used Codes	66
4.11.5	Clear Old Codes.....	66
4.12	Code Sales Lockout.....	66
4.12.1	Lock Console Sales	67
4.12.2	Change Lockout Password	67
4.13	Check Code Status	67
4.14	Setup a Feature	68
4.14.1	Change Feature Name.....	68
4.14.2	Assign a Postscript Message to a Feature.....	69
5	Cashier Operations	70
5.1	Issuing A Customer Ticket.....	70
5.2	Issuing Multiple Customer Tickets.....	71
5.3	Issuing A Rain check Receipt.....	71
5.4	Checking a Customer Code.....	71
5.5	Voiding a Customer Code.....	72
6	Customer Access	74
6.1	Cash Upgrades (Buy ups) at the Carwash Entrance	74
6.1.1	BUYUP: Automatic By Price.....	75
6.1.2	BUYUP: Audit-Selected-Options	76
6.1.3	Buy up: Forced Selection (Available for E-systems 4000 only).....	76
6.2	Customer Stacking	77
7	Printer Instructions	78
7.1	Instructions for Citizen Model CD-3535	78
7.1.1	General Cautions	78
7.1.2	Setting and Removing the Printer Cover.....	79
7.1.3	Ribbon and Cassette Installation.....	79
7.1.4	Loading and Changing the Paper.....	80
7.1.5	Actuating the Print Functions	81
7.1.6	Alarm and Paper Near-End Detection.....	81
7.1.7	DIP Switch Settings.....	82
7.2	Instructions for Citizen Model CD-S500	82
8	Backup Operations.....	84
8.1	Programming the Change-Codes Password.....	85
8.2	Programming Backup Customer Codes	85
8.3	Programming the Output Relays	86
9	Troubleshooting	87
9.1	Printer Doesn't Print.....	87
9.2	System Locked Up.....	87

9.3	Customer Buzzer Failure	87
9.4	Code Stacking Does Not Work	88
9.5	"Enter Wash" Signal Does Not Work	88
9.6	"Reenter Code" Signal Does Not Work	89
9.7	Bill, Coin or Audit Inputs Do Not Work.....	89
9.8	Main Console Keys Do Not Work	89
9.9	System Resets Each Time Power Is Turned On.....	89
9.10	Main Console Is "DEAD".....	89
Appendix A. Interfacing to an External Point-of-Sale		92
Appendix B. Multiple Unit Configuration		98
Appendix C. Reconciliation of Sales When Connected to an EXTPOS Device.....		101
Appendix D. Changing the Wash Description Insert Pocket on Version 2 Style Cases		103
Appendix E. Application Notes for Using Default Discounts Function		104
Appendix F. Application Notes for Using the Reverse Order Function.....		106

Index of Figures

Figure 1. POS4000 Keypad	2
Figure 2. POS4000 Connections	8
Figure 3. POS EPROM Location	13
Figure 4. EPROM and Socket.....	14
Figure 5. Setting and Removing the Printer Cover	79
Figure 6. Installing the Printer Ribbon and Cassette	80
Figure 7. Loading the Printer Paper.....	81

Index of Tables

Table 1. POS4000-WSII Connections	4
Table 2. Connector-Pin Communications Link to POS4000 Console	9
Table 3. Connections to Carwash Controller	9
Table 4. Connections to Customer Entry system.....	10
Table 5. Power and Audit Connections.....	10
Table 6. Function Lines.....	11
Table 7. Interface Board DIP Switch Setting for Test Mode	15
Table 8. Interface Board DIP Switch Setting for Normal Operations	15
Table 9. Interface Board Tests.....	15
Table 10. Relay Continuity Check for Common and Output Connectors	17
Table 11. Interface Board Connector Pins.....	18
Table 12. Key Continuity Check.....	19
Table 13. E-System Dispense Mode	31
Table 14. Setting Up Multi-Use Code Feature	40
Table 15. POS4000/WSII Accounting Report Cross Reference.....	52
Table 16. Printer DIP Switch Settings.....	82
Table 17. Citizen CDS500 Printer Settings.....	82
Table 18. Password Types.....	84
Table 19. Output Relays	86

[THIS PAGE INTENTIONALLY LEFT BLANK]

Quick Start Guide

(Pull Out Reference)

[THIS PAGE INTENTIONALLY LEFT BLANK]

The following commands are lists of steps that would typically be performed on a new POS4000 prior to use. For further information, see Section 4, Management Operations.

SET DATE AND TIME

Example to set time to Monday 04:30PM on 05/06/93:

```
[CMD]
[SYSTEM SETUP]
[3]                (password 3)
[ENTER]
[MENU UP/DOWN] until "Set System Time" is displayed
[ENTER]
[0][5][0][6][9][3][1][6][3][0]
[ENTER]
[2]                (Monday)
[ENTER]
```

NAME WASH FEATURES

Example to change the name of feature 1 to "ECONO-WASH":

```
[CMD]
[FEATURE 1]        (cashier key)
[1]                (password 1)
[MENU UP/DOWN] until "Change Wash Name" appears
[ENTER]
[E][C][O][N][O][ ][-][W][A][S][H]
[ENTER]
```

**Note:**

To type [-] you must press [SHIFT] to switch to upper characters then [-] (on the [R] key) then [SHIFT] again to return to the lower characters).

CONFIGURE GROUPS (Not used in all configurations)

Example to set Group 3 to Program 1 and options 1, 2 & 4:

```
[CMD]
[SYSTEM SETUP]
[3]                (password 3)
[ENTER]
[MENU UP/DOWN] until "Configure a Group" is displayed
[ENTER]
[3]                (select group #3 to configure)
[ENTER]
[Prog 1]           (select wash functions in group)
[Opt 1]
[Opt 2]
[Opt 4]
[ENTER]
```

SET PRICING

Example to set regular (full) price structure:

```
[CMD]
[SET PRICES]
[2]                               (password 2)
[ENTER]
[MENU UP/DOWN] until "Set Regular Prices" appears
[ENTER]
[3][5][0]                         (set feature 1 full price to $3.50)
[ENTER]
[4][7][5]                         (set feature 2 full price to $4.75)
[ENTER]
*                               (continue through all features)
*
[ENTER]
```

DISABLE UNUSED CASHIER KEYS

Example to disable PROGRAM 5:

```
[CMD]
[SYSTEM SETUP]
[3]                               (password 3)
[ENTER]
[MENU UP/DOWN] until "Disable Cashier Key" is displayed
[ENTER]
[Prog 5]                         (disable program 5)
[ENTER]
```

DEFINE HEADER MESSAGE

Example to change header message text:

```
[CMD]
[SET MESSAGES]
[1]                               (password 1)
[ENTER]
[MENU UP/DOWN] until "Change Header Msg." appears
[ENTER]
[9][9]                           (to change all lines of message)
[ENTER]
[T][H][I][S][ ][I][S][ ][A][ ][T][E][S][T]
[ENTER]
*                               (repeat for each line)
*
[ENTER]
```

DEFINE POSTSCRIPT MESSAGES

Example to change Postscript message 1:

```
[CMD]
[Set Messages]
[1] (password 1)
[ENTER]
[MENU UP/DOWN] until "Change Postscript 1" appears
[ENTER]
[9][9] (to change all lines of message)
[ENTER]
[T][H][I][S][ ][I][S][ ][A][ ][T][E][S][T]
[ENTER]
* (repeat for each line)
*
[ENTER]
```

ASSIGN POSTSCRIPT MESSAGES

Example to assign postscript message 3 to Opt 2 at all price levels:

```
[CMD]
[Opt 2] (cashier key)
[1] (password 1)
[ENTER]
[MENU UP/DOWN] until "Set Postscript All $" appears
[ENTER]
[3] (select postscript message 3)
[ENTER]
```

SET UP A FLEET ACCOUNT

Example to create a fleet account with code 1234560 valid for Program 1 + Option 1 + Option 3:

```
[CMD]
[ACCOUNT INFO]
[2] (password 2)
[ENTER]
[MENU UP/DOWN] until "Add an Account" is displayed
[ENTER]
[A][B][C][ ] [T][A][X][I][S] (ABC TAXIS)
[ENTER]
[1][2][3][4][5][6] (account code)
[ENTER]
[4][5] (the code is valid 45 times)
[ENTER]
```

[3][5][0] (\$3.50 value for each use of code)
[ENTER]
[Prog 1] (account feature selections)
[Opt 1]
[Opt 3]
[ENTER]

ISSUE AND CHECK WASH TYPES (see Section 5.1)

Examples for cashier-issued wash tickets:

Example: Full price P1 & O1
[Prog 1]
[Opt 1]
[ENTER]

Example: Full price-P2 & discount 1-O1
[Prog 2]
[DISC 1][Opt 1]
[ENTER]

Example: Discount 2-P2 & discount 2-O1 & discount 2-O2
[DISC 2][Prog 2]
[DISC 2][Opt 1]
[DISC 2][opt 2]
[ENTER]

CLEAR COUNTS

Example to clear AUDITOR level of counts:

[CMD]
[CLEAR REPORTS]
[MENU UP/DOWN] until "Clear Auditor Counts" appears
[ENTER]
[5] (password 5)
[ENTER]

Quick Reference Guide

(Pull Out Reference)

[THIS PAGE INTENTIONALLY LEFT BLANK]

The following examples demonstrate how to perform some of the most common functions of the POS4000. For a complete list of commands, see Section 4.

CASHIER OPERATIONS

ISSUE A TICKET: (Code valid for Program 1 and Option 1)

[Prog 1]
[Opt 1]
[ENTER]

ISSUE MULTIPLE TICKETS: (print 5 tickets in this example)

[5] (key located on management keypad)
[Prog 1]
[Opt 1]
[ENTER]

ISSUE A RAINCHECK:

[RAIN CHECK]

CHECK A CODE: (check code 123450 in this example)

[CMD]
[CHECK CODE]
[1][2][3][4][5] (code to check, 0 is optional)
[ENTER]

VOID A CODE: (void code 123450 in this example)

[CMD]
[VOID CODE]
[1] (password 1)
[ENTER]
[1][2][3][4][5] (code to void, 0 is optional)
[ENTER]

PRINT ACCOUNTING REPORT: (but do not clear counts)

[CMD]
[PRINT REPORT]
[MENU UP/DOWN] (Scroll to Report Desired)
[ENTER] (report prints)

PRINT ACCOUNTING REPORT AND CLEAR COUNTERS:

[CMD]
[CLEAR REPORTS] (clear counters)
[MENU UP/DOWN] (Scroll to Report Desired)
[ENTER]
[1],[2] or [5] (passwords 1, 2 or 5 respectively)
[ENTER]

MANAGEMENT OPERATIONS

SET TIME

Example to set time to 07:15AM on 05/22/93

```
[CMD]
[SYSTEM SETUP]
[3] (password 3)
[ENTER]
[MENU UP/DOWN] until "Set System Time" appears
[ENTER]
[0][5][2][2][9][3][0][7][1][5] (MMDDYYHHMM)
[ENTER]
[2] (for Monday)
[ENTER]
```

SET PRICING

Example to set full price pricing

```
[CMD]
[SET PRICES]
[2] (password 2)
[ENTER]
[MENU UP/DOWN] until "Set Regular Prices" appears
[ENTER]
[3][5][0] (set 1st function full price to $3.50)
[ENTER]
[4][7][5] (set 2nd function full price to $4.75)
[ENTER]
*
*
*
[ENTER]
```

CHANGE HEADER MESSAGE TEXT

```
[CMD]
[SET MESSAGES]
[1] (password 1)
[ENTER]
[MENU UP/DOWN] until "Set Header Message" appears
[ENTER]
[9][9] (to change all lines of message)
[ENTER]
[T][H][ ][S][ ][ ][S][ ][A][ ][T][E][S][T]
[ENTER]
* (Repeat for each line)
*
*
[ENTER]
```

CHANGE FOOTER MESSAGE TEXT

```
[CMD]
[SET MESSAGES]
[1] (password 1)
[ENTER]
[MENU UP/DOWN] until "Set Footer Message" appears
[ENTER]
[9][9] (to change all lines of message)
[ENTER]
[T][H][I][S][ ] [I][S][ ] [A][ ] [T][E][S][T]
[ENTER]
* (Repeat for each line)
*
*
[ENTER]
```

DEFINE POSTSCRIPT MESSAGE TEXT

```
[CMD]
[SET MESSAGES]
[1] (password 1)
[ENTER]
[MENU UP/DOWN] until "Set Postscript Message 1" appears
[ENTER]
[9][9] (to change all lines of message)
[ENTER]
[T][H][I][S][ ] [I][S][ ] [A][ ] [T][E][S][T]
[ENTER]
* (Repeat for each line)
*
*
[ENTER]
```

ASSIGN POSTSCRIPT MESSAGES TO WASH FUNCTIONS

Example to assign postscript message 3 to print on tickets that contain Opt 2 at any price level

```
[CMD]
[Opt 2]
[1] (password 1)
[ENTER]
[MENU UP/DOWN] until "Set Postscript # All $" appears
[ENTER]
[3] (select postscript message 3)
[ENTER]
```

SYSTEM CONFIGURATION COMMANDS

CHANGE A PASSWORD

Example to change password 1 to "123"

```
[CMD]
[PASSWORDS]
[3] (password 3)
[ENTER]
[MENU UP/DOWN] until "Change Password 1" appears
[ENTER]
[1][2][3] (new password)
[ENTER]
```

CHANGE CASHIER KEY NAME

Example to change Option 1 to Wax

```
[CMD]
[OPT 1] (this is the cashier key to re-label)
[1] (password 1)
[ENTER]
[MENU UP/DOWN] until "Change Wash Name" appears
[ENTER]
[W][A][X]
[ENTER]
```

CONFIGURING A GROUP WASH

Example to Configure Group 3 to be Program 1 and Options 1 & 4

```
[CMD]
[SYSTEM SETUP]
[3] (password 3)
[ENTER]
[MENU UP/DOWN] until "Configure a Group" appears
[ENTER]
[3] (management keypad, select group #3 to configure)
[ENTER]
[Prog 1] (select wash functions in group)
[Opt 1]
[Opt 4]
[ENTER]
```

FLEET ACCOUNT COMMANDS

ADD A FLEET ACCOUNT

Example to add account with code 1234560

```
[CMD]
[ACCOUNT INFO]
[2] (password 2)
[ENTER]
[MENU UP/DOWN] until "Add an Account" appears
[ENTER]
[A][B][C][ ][T][A][X][I][S] (account name)
[ENTER]
[1][2][3][4][5][6] (account code 123456)
[ENTER]
[4][5] (code is valid 45 times)
[ENTER]
[3][5][0] ($3.50 value for each use of code)
[ENTER]
[1] (Print receipt when account is used)
[ENTER]
[Prog 1] (account wash selection)
[Opt 1]
[Opt 3]
[ENTER]
```

LIST A FLEET ACCOUNT

```
[CMD]
[ACCOUNT INFO]
[2] (password 2)
[ENTER]
[MENU UP/DOWN] until "List an Account" appears
[ENTER]
[1][2][3][4][5] (enter account number)
[ENTER]
```

DELETE A FLEET ACCOUNT

Example to delete account 1234560

```
[CMD]
[ACCOUNT INFO]
[2] (password 2)
[ENTER]
[MENU UP/DOWN] until "Delete an Account" appears
[ENTER]
[1][2][3][4][5][6] (account to delete)
[ENTER]
```

MODIFY A FLEET ACCOUNT

Example to reset # washes to 30 for account 123456

```
[CMD]
[ACCOUNT INFO]
[2]                (password 2)
[ENTER]
[MENU UP/DOWN] until "Reset # of Washes" appears
[ENTER]
[1][2][3][4][5][6] (account code 123456)
[ENTER]
[3][0]            (make account good for 30 washes)
[ENTER]
```

LIST OF COMMANDS

The primary commands and the required passwords are shown below along with their secondary commands:

<u>Primary/Secondary Command</u>	<u>Key Label</u>	<u>Password</u>
Fleet Accounts	Account Info	2

The following Fleet Account menu lists the menu commands available with the stand alone POS4000/V2:

- Print All Accounts
- Add an Account
- Delete an Account
- Print 1 Account
- Reset # of Washes
- Delete Empty Accounts

When using the WSII and POS4000/V2 together (POS4000/V2 Software Version 7.90 and higher and WSII Software Version 4.20 and higher), you will see the following Fleet Account menu:

- Add Account
- Edit Account
- Add to an Account
- Delete Account
- Print Account
- Print All Accounts
- Print Trans History
- Delete All Empty
- Erase All Accounts

The procedures for using these commands are identical to the procedures used at the WSII. Refer to the WSII POS Operations Manual "Fleet Accounts and Coupons" section for more information on these commands.

System Configuration	System Setup	3
Set System Time		
Relay Latching		
Relay Stacking		
Configure a Group		
Set Code Age Warning		
Set Code Length		
Disable Cashier Key		
Set Serial Baud Rate		
Set Languages		
Set Program Relays		
Cash Upgrades MENU->		
Set BUYUP Mode		
Set Coin/Bill Values		
Set Dispense Value		
Set Dispense Mode (E-4000 only)		
External POS MENU->		
Set POS Offset		
Define EXT. POS Type		
Set POS MAX WASHES		
Multiple Unit MENU->		
Set Unit Number		
Controller/Remote		
Set # Bays/Consoles		
Prog Remote Consoles		
Set modem rings		
E-Systems Menu->		
Enab/Disab Change (E-4000 only)		
Enab/Disab Displays (E-4000 only)		

Each sub-menu also contains an option to "Return to SETUP MENU"

Print Audit Counts	Print Report	None
Print Shift/Manager		
Print Auditor/Non R.		
Set Pricing	Set Prices	2
Set Regular Prices		
Set Discount 1 Price		
Set Discount 2 Price		
Print Pricing Report		
Set Tax Rate		

Enable TAX Round Off

Service Routines	Service	4
Print Configuration		
Link Test		
LED Test		
Print (codes) to display		
Display POS Diags		

Clear Audit Counts	Clear Reports	
Clear Shift Counts		1
Clear Manger Counts		2
Clear Auditor Counts		5

Set Messages	Set Messages	1
Change Header Msg.		
Change Postscript 1		
Change Postscript 2		
Change Postscript 3		
Change Postscript 4		
Change Postscript 5		
Change Footer Msg.		
Change Coinbox Msg. (E-4000 only)		
Print Message Config		

Set Passwords	Passwords	3
Change Password 1		
Change Password 2		
Change Password 3		
Change Password 5		
Change Serial Pass		

Void a Code	Void Code	1
--------------------	------------------	----------

Memory Information	Memory	2
Print Valid Codes		
Print Used Codes		
Clear ALL Valid		
Clear ALL Used		
Clear Old Codes		

Check Code Status	Check Code	None
Setup Feature	CASHIER KEYS	1
Change Wash Name		
Set Reg. Postscript		
Set Dis 1 Postscript		

Set Dis 2 Postscript
 Set Postscript All \$

Summary of access provided by each password:

Password	User	Commands
1	Cashier	Clear SHIFT level counters, Void codes, Define Messages, Setup Features
2	Manager	Clear MANAGER level counters, Fleet Accounts, Set Pricing, Memory Information
3	Supervisor	System Configuration, Change Passwords
4	Service	Service Routines
5	Auditor	Clear AUDITOR level counters

[THIS PAGE INTENTIONALLY LEFT BLANK]

1 Overview

The POS4000 is a car wash access controller that provides both a merchandising tool and cash security. The system consists of a main console, which is typically located near the cashier, and the Wash Select II (WSII) entry system that is typically located at the entrance of the car wash. The entry system can be part of a simple “Code Only” entrance stand or feature cash acceptance as a “Coin Box”.

The main console allows cashiers and managers to generate customer access codes, generate management reports and configure access control. These various functions are selected by using the keys on the main console.

The customer interface electronics include:

- Relays used to control customer guidance lights and activate the car wash
- A keypad used by customers to enter access codes
- Optional coin and bill acceptor inputs (to allow customers to upgrade at the car wash entrance)
- Optional change making capabilities
- An optional alphanumeric display used to prompt the customer

The configurations for the Customer Interface electronics vary by wash manufacturer. The POS4000 provides functionality and commands to support a wide variety of the Carwash professional’s needs. You may find that many of the functions and commands in the POS4000 will not apply to your particular installation.

Fleet accounts are used to provide a pre-defined number of washes to a customer. This feature is useful in selling carwashes to organizations (i.e. police or fire departments), providing carwashes to employees and giving discounts for purchasing multiple washes. Once a fleet account has been established, the number of washes that it is valid for can be modified without changing the other account information. All fleet account accounting is maintained by individual account.

A unique carwash grouping feature allows the operator to merchandise individual carwash functions as well as merchandising carwash packages with special pricing. A carwash group is user definable and sold using a single key on the cashier keypad. For example, a WORKS carwash could be merchandised to include a deluxe wash with all options. This package would have a separate 3 tier pricing structure and separate accountability. Group functionality is not supported by all entry system configurations, and is typically most usable in systems that don’t allow cash acceptance at the customer entrance stand.

A very flexible carwash message structure is provided that enables one to provide the customer with a variety of information. Custom header and footer messages can each be up to 10 lines long and are printed on the top and bottom of every ticket.

In addition to the header and footer messages, five different postscript messages, each 5 lines long, can be defined and assigned to specific carwash features at specific price levels. This allows different messages to be printed on full priced and discounted tickets. This flexibility allows you to advertise discounts to customers paying full price, allows full priced tickets to be saved as coupons toward future purchases, allows you to thank customers who earned a discount for purchasing the goods and services that enabled them to earn the discount, etc.

The operation of the system is somewhat dependent on the options present and configuration of the unit. This information can be obtained by using the system configuration report command (see SECTION 4.1). However, general operations are very similar for all systems.

1.1 Keypad Layout

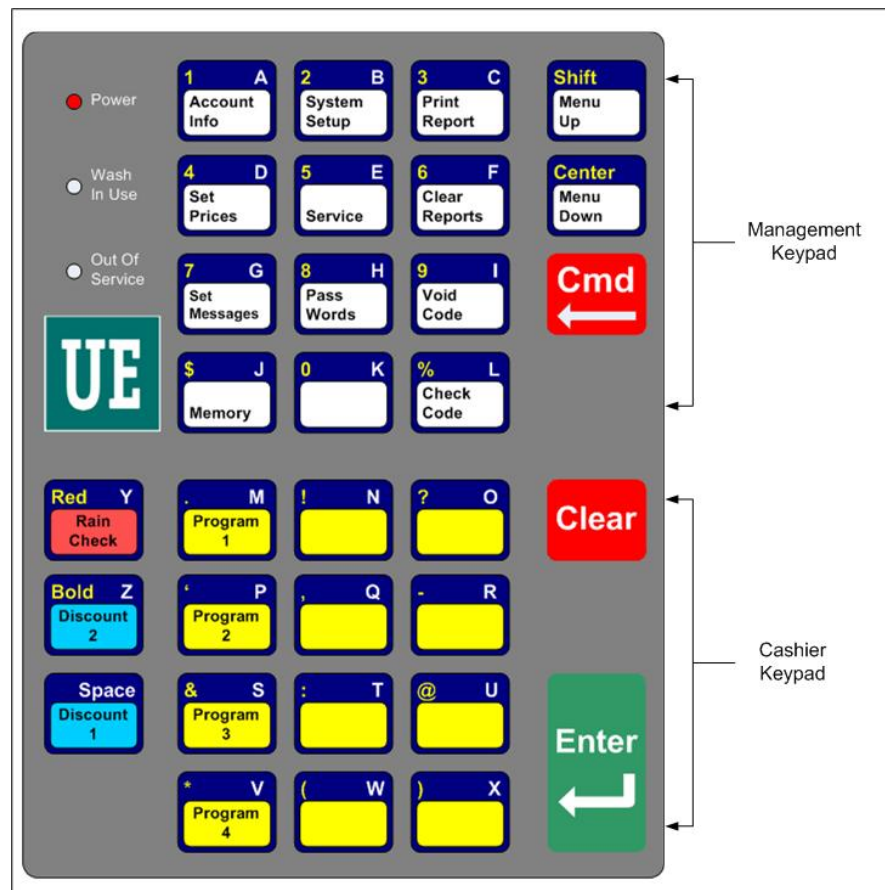

Figure 1. POS4000 Keypad

During various commands, you will be prompted to enter alphanumeric responses. To do this, you must use the alternate characters printed on the right hand side of the keys. These alternate key values automatically become active when the console requires alphanumeric data entry. Note that each alternate key has two characters printed on the top and bottom right hand side of the key. When the console requests alphanumeric data, the bottom characters will initially be active. You can switch back and forth between the top and bottom values by using the [SHIFT] key.

Several special keys simplify alphanumeric data entry:

- **[SHIFT]** is used to toggle between the top and bottom selection on the alternated keypad during alphanumeric data entry.
- **[BACKSPACE]** is used to erase the previous character.
- **[CLEAR]** has several uses depending upon what information the POS4000 is expecting. During alphanumeric text entry (i.e. header message), it is used to erase the entire line of data entered and to start the line over. During feature selection, it clears all current features. During numeric entry (e.g. passwords), it clears the number and allows you to re-enter it.

- **[SPACE]** is used to add a blank space in the text.
- **[ENTER]** is used to end the current line of text.
- **[CENTER]** will center the text entered. Press once during the text entry of the line to center.
- **[RED]** is used to print the text in red. Press once during the text entry of the line to print the entire line in red.

[RED] is an upper function, therefore it may be necessary to press [SHIFT] prior to pressing this key.

- **[BOLD]** is used to print the text in Bold (double high and double wide). Press it once during the text entry of the line to print in bold. When a line of text is printed in bold, only half the number of characters of text can be used in that line.

[BOLD] is an upper function, therefore it may be necessary to press [SHIFT] prior to pressing this key



Note: Pressing both [RED] and [BOLD] during text entry will print that line in bold red.

1.2 Wash Select II POS System

The Wash Select II may be configured to interface to a POS4000 in order to be activated by Codes sold at one or multiple POS4000 units. This is how a Wash Select II/POS is configured to operate. Any Wash Select II may also be upgraded in the field to interface to a POS4000 either by direct wires or via RF (Radio Frequency) interface.

Upgrading a Wash Select II to interface to a POS4000 requires the following:

- Version 1.20 or greater software installed into the Wash Select II
- POS4000 with Version 7.20 or greater installed.
- Wash Select II 485 communications module. This plugs into the top left corner of the Wash Select II CPU board.
- Cable to connect POS4000 to the Wash Select II 485 communications module
- RF transceivers (Optional if your cable connection between the POS4000 and Wash Select II is not feasible)

The Wash Select II may be configured to convey accounting information to the POS4000 or to withhold that financial information. If you are in a revenue share agreement, you may want to withhold the information. If not, you should convey the accounting information to allow the POS4000 to see the money that is being entered into the Wash Select II entry system.

The Wash Select II is mostly configured at the Wash Select II entry system. Most of the entry system settings in the POS4000 are not used by the Wash Select II. You may, however, configure the Wash Select II to accept the Wash names and Prices of the POS4000. If enabled, the Names and Prices at the WSII are automatically updated to the price at the POS after a power cycle at the WSII or after loss of communications for over 20 seconds (Software versions 7.4 for POS and 3.01 for WSII).

Here is a list of functions and features that must always be programmed at the Wash Select II entry system:

- Fleet profiles
- Credit system
- Speech recordings and settings
- Receipt Header
- Wash Interface (Relay Stacking, Relay Latching, Out of Service etc... POS4000 settings are ignored)
- Customer Interface (Upgrades, forced selection, Customer stacking etc...)
- Paging functions
- Cash and Token settings.
- System time, Printer config, Site ID, and Service Phone #
- VIP Wash Coupons™
- Passcodes & Passcards

If the wash names and prices in the Wash Select II do not match the POS4000 then turn on “Use POS Names/\$” function in the POS Link menu of the Wash Select II and reprogram the Regular prices in the POS4000. You may also program the names and prices directly into the Wash Select II.

Here is a step-by-step guide to setting up the Wash Select II™ unit to interface to a POS4000.

1. If not already installed, with the power off, install the Wash Select II™ 485 communications module onto the top left corner of the Wash select II™ CPU board. The board is installed with the LED’s on the bottom
2. Turn on the Wash Select II™ and put it into setup mode. If you have more than one bay, set the units up one at a time, with un-configured units turned off.

3. Wire the POS4000 cable connections per the following connections:

Table 1. POS4000-WSII Connections

POS4000	Wash Select II Connector J22
Pin 1 – White	Pin 1 – White
Pin 2 – Red	Pin 2 – Red

Pin 3 – Black	Pin 3 – Black
Shield – Not connected	Shield, strap to base mounting bolt in case.

4. If the POS4000 is connected and both units are powered, the receive light on the 485 communications module should be blinking every couple of seconds. If the light is not blinking, you may have a failed connection or a failed POS4000. A failed communications module is also possible.
5. Enter the POS4000 Link sub menu (refer to the WSII Operating Manual) and enable the interface.
6. Set the bay address per the instructions in the WSII Operating Manual.
7. Set the unit to Operate mode. You should see both the receive light and the transmit light on the Wash Select II™ 485 communications module begin to blink within 10 seconds. They should blink one after the other with a pause of less than a second between blinking. If you have more than one bay then the receive light should be on longer than the transmit light.
8. Set the unit back into setup mode and continue configuring the other settings.

[THIS PAGE INTENTIONALLY LEFT BLANK.]

2 Installation

These instructions should be used as a guideline. If the wash manufacturer you purchased the system from provides more detailed wire and installation instructions then please ignore the following information.

2.1 Pre-Installation Requirements



Note:

If your system comes with separate entry system installation instructions then follow them for the entry system and use the following references to POS4000 Console installation only.



Warning:

Never run the communications lines in the same conduit as wires used in powering the entry system or the carwash.

- Conduit (3/4") from cashier (location of main console) to car wash entrance console (location of customer keypad)
- Conduit (3/4" minimum, 1" preferable) from car wash entrance console to car wash controller
- Dedicated duplex (120 Volts/60 Hz, 3 amps, grounded) receptacle at location of main console. One is required for the console and one for the printer. The socket outlet shall be installed near the equipment and shall be readily acceptable. Ground hole of receptacle must be properly connected to Earth Ground.
- POS4000 main console, printer and wall transformer
- POS4000 interface board with keypad
- POS4000 main console/interface cable (3 conductor, 22 gauge with shield)
- Control wires from car wash controller to POS4000 interface board



Note:

When installing multi-Console or Multi-Bay configurations refer to included drawings for instructions on daisy chaining the communications cable. Never wire the communications in a STAR configuration where splices occur at any point other than at the Consoles or Entrance stands.

2.2 Wiring

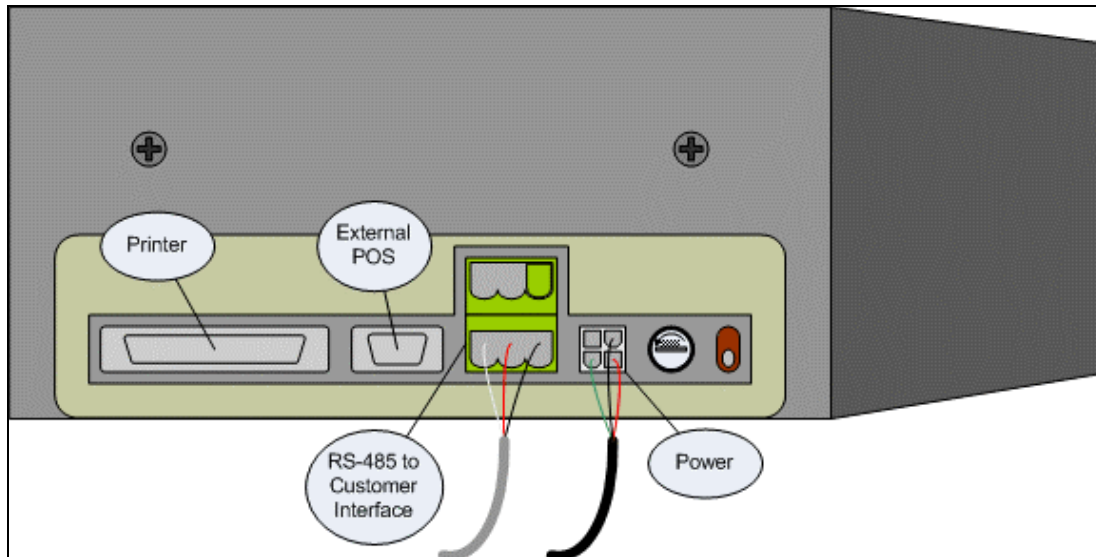

Figure 2. POS4000 Connections

The wall transformer plugs into a 3-prong earth grounded wall outlet, the connector at the end of the cord attaches to the mating connector on the back of the main console. This cord connects the power and Earth Ground connection to the Console.

The main console and interface board are connected by a communication cable. The correct communication wiring is pin 1 to 1, pin 2 to 2. The shield should be connected to earth ground at the interface board (connector C pin 4). See the wiring diagram in the table on the following page for more detail.

2.2.1 Wiring Information for POS4000 Interface Board

The following tables list the wiring information for the POS4000 Interface Board.

	Note:	>	is a signal input to interface board
		<	is a signal output from interface board

Table 2. Connector-Pin Communications Link to POS4000 Console

Interface Connector	Direction	Pin
C-1	<>	Pin 1 (RS485 -)
C-2	<>	Pin 2 (RS485 +)
C-3	<>	Pin 3 (Signal GND) (not connected)
C-4	<>	Earth Ground (connected to Earth manually or via Hard wired Earth ground cable)

	Note:	On POS4000 Interface boards with Version 6.6 Hardware the Pin C-4 is connected internally to Signal Ground.
---	--------------	---

Table 3. Connections to Carwash Controller

Connector	Direction	Controller Connection
D-1	>	Car Wash "IN USE" Signal
D-1	>	Car Wash "IN-USE" Neutral
A1-8	>	Car Wash Voltage to activate wash functions
B-1	<	Function 1*
B-2	<	Function 2*
B-3	<	Function 3*
B-4	<	Function 4*
B-5	<	Function 5*
B-6	<	Function 6*
B-7	<	Function 7*
B-8	<	Function 8*

*See Section 2.3 for "Function" descriptions

Table 4. Connections to Customer Entry system

Connector	Direction	Entry system Connection
A-7	>	Power for customer lights
A-6	<	"Out-of-Service" light
A-5	<	"Enter Wash" light (Code valid)
A-4	<	"Code Accepted / Wait" light
A-3	<	"Reenter Code" light (code invalid)
D-3	>	Quarter mechanism voltage pulse (credit)
D-4	>	Quarter mechanism voltage neutral
D-5	>	Bill mechanism voltage pulse (credit)
D-6	>	Bill mechanism voltage neutral

Table 5. Power and Audit Connections

Interface Connector	Direction	Power/Audit Connection
A-1	>	24VAC HOT power to interface board (or 24VDC+)
A-2	>	24VAC neutral (or 24VDC-)
D-7	>	Audit 1 Voltage Input
D-b	>	Neutral for ALL audit voltage inputs
D-9	>	Audit 2 Voltage Input
D-10	>	Audit 3 Voltage Input
D-11	>	Audit 4 Voltage Input
D-12	>	Audit 5 Voltage Input

2.3 POS4000 Function Lines/Car Wash Features

The function control lines used to start the specific car wash features purchased by the customer are identified as "function lines 1 - 8". The use of these lines is dependent on the specific software program in the POS4000 console. The uses of the function lines are given in the table on the following page by the type and number of program. To determine your POS4000 configuration, check the system configuration report

Table 6. Function Lines

# of Programs	Interface Function Line							
	1	2	3	4	5	6	7	8
Multi-pulse*	Pulsed	Opt 1	Opt 2	Opt 3	Opt 4	Opt 5	Opt 6	Opt 7
1 Program	Prog 1	Opt 1	Opt 2	Opt 3	Opt 4	Opt 5	Opt 6	Opt 7
2 Programs	Prog 1	Prog 2	Opt 1	Opt 2	Opt 3	Opt 4	Opt 5	Opt 6
3 Programs	Prog 1	Prog 2	Prog 3	Opt 1	Opt 2	Opt 3	Opt 4	Opt 5
4 Programs	Prog 1	Prog 2	Prog 3	Prog 4	Opt 1	Opt 2	Opt 3	Opt 4
5 Programs	Prog 1	Prog 2	Prog 3	Prog 4	Prog 5	Opt 1	Opt 2	Opt 3
6 Programs	Prog 1	Prog 2	Prog 3	Prog 4	Prog 5	Prog 6	Opt 1	Opt 2
7 Programs	Prog 1	Prog 2	Prog 3	Prog 4	Prog 5	Prog 6	Prog 7	Opt 1
8 Programs	Prog 1	Prog 2	Prog 3	Prog 4	Prog 5	Prog 6	Prog 7	Prog 8

* In multi-pulse operation, Function line 1 is pulsed 1, 2, 3 etc. times to issue different carwash programs.



Note:

If your configuration has fewer than the maximum options (as indicated in the table above), then the upper function lines are not used. For example, if you have 3 programs and 3 options then lines 7 and 8 are not used.

2.4 Installing/Upgrading the EPROM Chip

**Warning:**

Depending upon the version of software that is currently in the console, this procedure may delete ALL configuration information, including all codes, fleet accounts, and accounting information. All setup configurations will be reset to factory defaults. To properly facilitate reprogramming this information, you should print the following reports BEFORE proceeding:

- System configuration
- Pricing report
- Fleet accounts
- Accounting reports (those that are used)
- Message configuration

Perform the following steps to change the POS4000 console software (EPROM):

1. Disconnect all cables to the console
2. Remove the plastic housing. To do this you must remove 2 screws from the rear and 2 screws from the bottom of the unit.
3. The upper chassis must be partially removed. Remove the middle and front screws along the side of the metal chassis. Loosen the rear two screws on each side of the chassis. This will allow the top piece to open up revealing the main circuit board.
4. Find the EPROM chip, as indicated below:

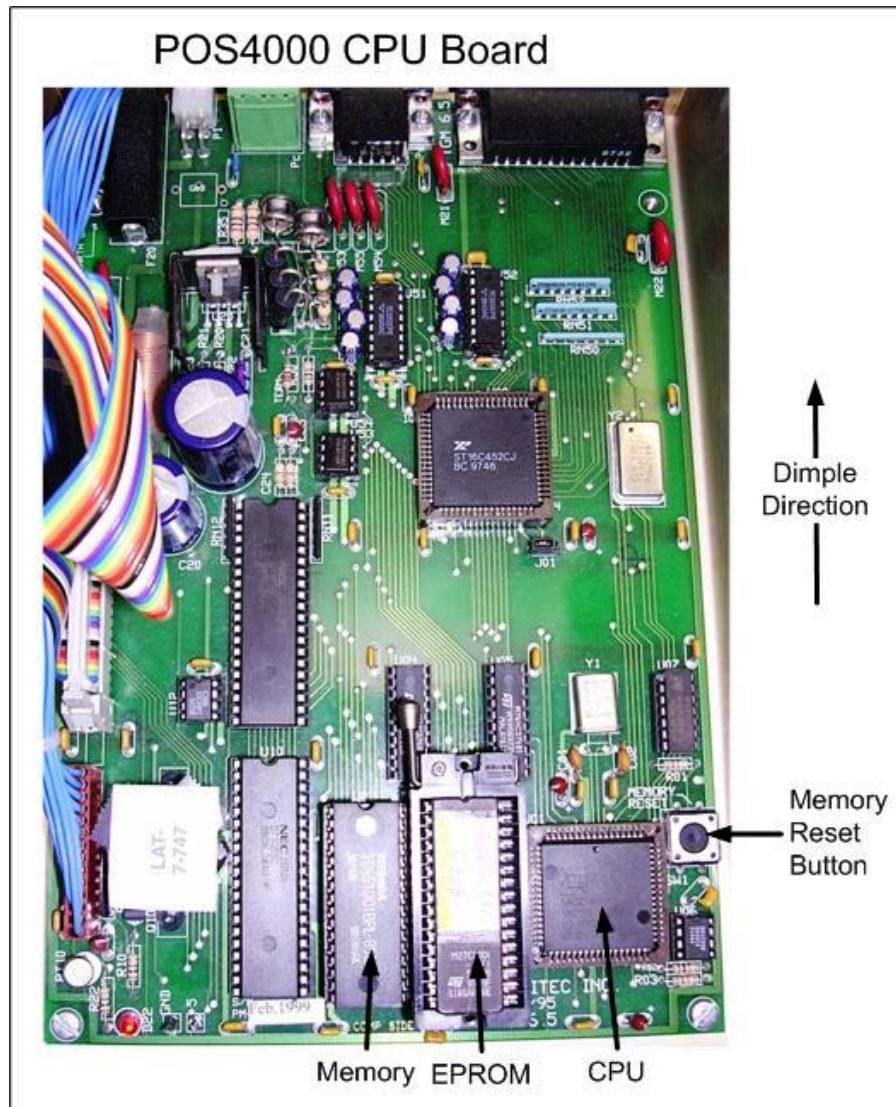

Figure 3. POS EPROM Location

The EPROM chip has a small window on the top surface that may or may not be covered with an adhesive label.

5. Carefully remove the EPROM chip from the socket. Use a small flat head screw driver or an IC remover. Be careful to pry the chip from the socket and not the socket from the board.

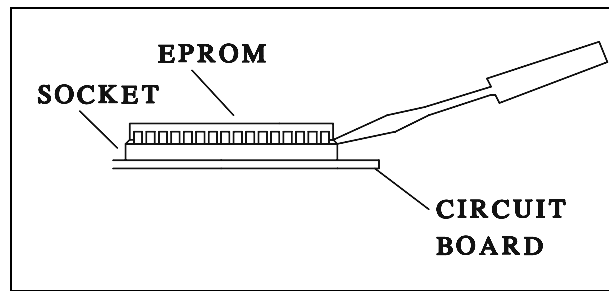

Figure 4. EPROM and Socket

6. Carefully install the new EPROM into the socket. Make sure that the Dimple on the chip is facing the same direction as it was before (refer to previous drawing). Also, make sure that pins can be properly inserted into the sockets without bending. Component legs can be bent to fit sockets as follows:
 - Lay the chip on its side with the pins facing away from you.
 - Gently rock the chip away from you to bend the pins.
 - Lay chip on its other side and rock it away from you.
 - Repeat the above steps, alternating sides of the chip until the pins line up in the socket without forcing the legs to fit.
7. Reconnect the power and printer connections and turn on the unit. As the system powers up the message “**!!SOFTWARE UPGRADE!!**” will appear momentarily.
8. After the unit is powered up, you **MUST** then press the **RESET BUTTON** to reset the system.
9. After pressing the reset button, the display will prompt you to press 99 or 55. Press **55**.
10. Reset the system two more times. If your system previously contained standard version TG648 and above or Unicam version 656 and above, then the codes and messages should be retained.
11. Replace all screws and plastic cover. Connect all other cables previously attached.

3 Testing

The following information is for technical service personnel; Unitec does not recommend end users repair their own equipment. However the following information may be useful in helping the end user to get his or her system up and running without requiring a service call from the local equipment distributor.

3.1 Console Testing

During the installation and normal operations of the POS4000, there may be times when the system doesn't operate as expected. For example, power to the system interface card may be off. In order to expedite the checkout of the system, several service routines are provided. To access a service routine, press the [CMD] key followed by the [SERVICE] key. The console will request password level 4. Password 4 is always 62747. It cannot be changed and is intended for service personnel to use for installation and testing purposes. This is the only command that password 4 provides access to. For a specific discussion of this command, see Section 4.6.

3.2 Interface Board Testing

The POS4000 interface board has a test mode of operation. To activate this test mode you must change the dip switches on the interface board as follows:

Table 7. Interface Board DIP Switch Setting for Test Mode

DIP Switch	Setting
4	OFF
5	ON

Make sure you return the DIP switches to normal operation mode when testing is complete. For the normal operations, set the switches as follows:

Table 8. Interface Board DIP Switch Setting for Normal Operations

DIP Switch	Setting
4	OFF
5	OFF

While the interface board is in the test mode, the customer buzzer will beep approximately every 5 seconds. Once in the test mode, you select the specific test desired by typing the following codes at the customer keypad:

Table 9. Interface Board Tests

Code	Test
10	Output relay line 1 on
20	Output relay line 2 on
30	Output relay line 3 on

40	Output relay line 4 on
50	Output relay line 5 on
60	Output relay line 6 on
70	Output relay line 7 on
80	Output relay line 8 on
90	Re-enter code relay output on
110	Code Accepted/wait relay output on
120	Enter Wash relay output on
130	Out-of-Service relay output on
140	All relay outputs on
150	Wash In-Use input status
160	Coin credit input status
170	Bill credit input status
180	Audit 1 input status
190	Audit 2 input status
210	Audit 3 input status
220	Audit 4 input status
230	Audit 5 input status

3.2.1 Relay Test

To check a specific relay on the interface board, you should close that relay by entering the appropriate code at the customer keypad (while the board is in test mode). That relay will remain on until another selection is made or until the board is put back into the normal mode of operation. While the relay is on check continuity between the common and output connector pins of the specific relay as follows:

Table 10. Relay Continuity Check for Common and Output Connectors

Relay	Common	Output
Wash Function Line 1	A8	B1
Wash Function Line 2	A8	B2
Wash Function Line 3	A8	B3
Wash Function Line 4	A8	B4
Wash Function Line 5	A8	B5
Wash Function Line 6	A8	B6
Wash Function Line 7	A8	B7
Wash Function Line 8	A8	B8
Re-enter Code Relay	A7	A3
Code Accepted/Wait	A7	A4
Enter Wash Relay	A7	A5
Out-of-Service	A7	A6

3.2.2 Input Test

To check any of the inputs on the interface board, enter the appropriate code at the customer keypad. Then apply the appropriate voltage (120VAC or 24AC/DC) to the input being tested. While the appropriate voltage is on the specific input being tested, the customer buzzer will beep rapidly, while the voltage is off the customer buzzer beeps very slowly. If the optional customer display is connected, the status of the input is displayed.



Note:

An LED on the interface board should light while voltage is present. The location of the specific LEDs is shown in the "POS4000 Interface Board Wiring Diagram" in the back of this manual.

The connector pins for the specific inputs on the interface board are given below:

Table 11. Interface Board Connector Pins

Input	Hot	Neutral
Wash In-Use	D1	D2
Coin Credit Pulse	D3	D4
Bill Credit Pulse	D5	D6
Audit 1	D7	D8
Audit 2	D9	D8
Audit 3	D10	D8
Audit 4	D11	D8
Audit 5	D12	D8

3.2.3 Keypad Test

To test the customer keypad, leave the interface board in the normal operations mode. As a first test, press each key one at a time and make sure the customer buzzer beeps when each key is pressed. Clear those entries by pressing the * key (some older units have a P key), then enter the two test sequences at the customer keypad: 123450 and 67890. After each entry, go to the POS4000 main console and read the customer code displayed on the bottom right of the console display. The displayed value should match the number that was entered at the interface board.

If one or two keys do not beep when pressed at the car wash entrance, it is likely a keypad failure. The keypad can be checked by making the following continuity checks: First, disconnect the KEYPAD PLUG from the interface board and check for continuity between the connector pins specified when a particular key is depressed.

Table 12. Key Continuity Check

Keys	Connector Pins
Key 1	Pins 1 & 7
Key 2	Pins 1 & 8
Key 3	Pins 1 & 9
Key 4	Pins 2 & 7
Key 5	Pins 2 & 8
Key 6	Pins 2 & 9
Key 7	Pins 3 & 7
Key 8	Pins 3 & 8
Key 9	Pins 3 & 9
Key * or P	Pins 4 & 7
Key 0	Pins 4 & 8
Key # or A	Pins 4 & 9

If any of these continuity checks fail, the keypad should be replaced.

If one row or column of customer keys fails, make keypad continuity check as described above first. If this passes, reconnect the keypad and check the wire connections between interface board and keypad. Make sure there are no broken wires and make sure all connectors are correctly mated. If the keypad test is OK and the wire connections are good, replace the interface board.

[THIS PAGE INTENTIONALLY LEFT BLANK]

4 Management Control (Command Reference)

The management keys are used to access the various commands available. The management keys are typically white and are located on the top half of the console keypad. They are used for alpha-numeric entries as indicated by the large numeric characters located on the upper right half of the keys and letters located on the lower right half of the keys. They are also used to select commands as indicated by the text on the center of the keys.

Two methods are available to select a primary command. The first method allows you to scroll through the primary menu list (by pressing the [MENU UP] or [MENU DOWN] key) and then select the command of interest by pressing the [ENTER] key. The second method allows you to directly access a particular primary menu command by simply pressing the [CMD] key followed by the desired command function key (as identified by the text on the management keys). For example, to print the wash counts report you either press the [MENU UP] and/or [MENU DOWN] keys until the "Print Audit Counts" menu item appears on the display and then press the [ENTER] key to select that command or you can simply press the [CMD] key followed by the [PRINT REPORT] key. Both methods will activate that primary command.

Many of the console primary commands require a password. Those that do will prompt for a specific password (password 1, password 2, ...) immediately after you select that command. To continue with the command, type the appropriate password (using the numbers printed on the management keys) followed by the [ENTER] key.

Many of the primary commands have a secondary command menu list. Once the primary command has been selected and the appropriate password entered, you scroll through the secondary menu list (using the [MENU UP] and/or [MENU DOWN] keys) and select the secondary command of interest by pressing the [ENTER] key.

After a secondary command is executed, the primary command remains selected. This allows several commands to be executed without having to re-enter the password. For example, all of the passwords can be changed once the "Set Passwords" command has been activated. To exit from a secondary menu and return the console to normal operation, scroll until "Press ENTER to QUIT" appears and then press the [ENTER] key.

The password structure is intended to provide various levels of access to the configuration of the POS4000 and the information that it maintains.

**Note:**

As you make numeric or character entries, the number/character is displayed. If a mistake is made during numeric entry, it can be corrected prior to depressing the [ENTER] key by pressing the [CLEAR] key and reentering the number. While entering alpha-numeric data (i.e. entering header message), the [CMD] key can be used as a backspace key.

4.1 System Configuration

The System Configuration command allows you to configure many aspects of the console operation to your specification. To select this command press the [CMD] key followed by the [SYS SETUP] key. You will be prompted to enter password 3. After entering the correct password, you can scroll through the secondary menu list that follows:

- Set System Time
- Configure a Group
- Set Code Age Warning
- Set Code Length
- Disable Cashier Key
- Set Serial Baud Rate
- Set Languages
- Set Program Relays
- Cash Upgrades MENU->
 - Set BUYUP Mode
 - Set Coin/Bill Values
 - Set Dispense Value
- External POS MENU ->
 - Set POS Offset
 - Set EXT. POS Type
 - Set POS Max Washes
 - Set Send Code Age
 - Reverse order
- Multiple Unit MENU ->
 - Set Unit Number
 - Controller/Remote
 - Set # Bays/Consoles
 - Prog Remote Consoles

To execute one of the secondary commands, scroll through the secondary menu until the command of interest is displayed, and then press the [ENTER] key. The final three entries in the secondary menu each allow access to a sub-menu. In addition to the choices shown for each sub-menu, there is also an item that allows you to "Return to SETUP MENU".

The following information is provided in the System Configuration Report:

- Software Version and date of release
- Car Wash manufacturer compatibility

- Console language - used for text displayed on main console
- Customer language - used for tickets and customer display
- Number of Programs/options/groups
- Type of program: Multi-pulse or single line per program
- Relay Stacking status: Enabled/Disabled (see Note 1)
- Interface Relay Type: Momentary/Latched
- Type of Customer Buy up: None/Automatic/Selected/Forced
- E-system configuration (Change and Wash displays)
- Tax Rate
- Tax Round Off: Enabled/Disabled (only if tax rate is non-zero)
- Serial Baud Rate for EXT POS Device: 19200/9600/4800/2400/1200
- Code length (including zero: 5/6/7)
- Code Age Warning: 0-31
- Set Send Code age
- Reverse order of EXTPOS washes
- Maximum number of fleet accounts
- Maximum number of valid codes stored in memory
- Maximum number of used codes stored in memory
- Default passwords (see Note 2)
- Cashier Key Status: All Enabled/Specific Disabled
- Group Configurations
- Customer interface type and version

The exact format of this information is subject to change as new features are added.



Note 1:

If relay stacking is disabled, the function relays are closed as soon as a code is entered (regardless of the wash in-use signal). If relay stacking is enabled, the function relays will not be closed until the wash in-use signal is off. In either case, a second customer can enter their code and/or deposit cash while a first customer is in the carwash.



Note 2:

The passwords listed are the default passwords (NOT necessarily the current passwords). Once a password has been changed, the default passwords will no longer work. The changed passwords are not listed for security reasons. It is the responsibility of the user to know the current passwords if they are changed from the default values

4.1.1 Set System Time and Date

To set the system date and time scroll through the System Configuration main menu until "Set System Time" appears. Once selected, the console will prompt for the date and time in the format MMDDYYHHMM (month, day, year, hour, minute). Two digits must be used for each entry (i.e.. 3 = 03) and all entries must be completed. Time is entered in military format (i.e.. 4:30PM is entered in the HHMM slot as 1630). After you enter the date and time, the console will prompt for the day of the week where Sunday = 1, Monday = 2 ... Saturday = 7.

As of Version 7.00, the POS4000 is Year 2000 compliant. All printed dates are in 4-digit format. However, whenever entering a date into the POS4000, 2-digit format is used. The 2-digit year conversion is as follows: 00-89 = 2000-2089, 90-99 = 1990-1999. The POS4000 will calculate the correct Date, Day of Week and Leap years until 2089.

As an example, Thursday May 6, 1999 4:37PM is entered as 0506991637 for MMDDYYHHMM and 5 for the day of the week. If an invalid date/time is entered, the console will display "Time Entry Error" and you will have to start over.

Example to set time to Thursday 04:37PM on 05/06/99:

```
[CMD]
[SYSTEM SETUP]
[3]                (password 3)
[ENTER]
[MENU UP/DOWN] until "Set System Time" is displayed
[ENTER]
[0][5][0][6][9][9][1][6][3][7]
[ENTER]
[5]                (Monday)
[ENTER]
```

4.1.2 Configuring a Group

If "Groups" are available on the cashier keys, this command can be used to configure the groups. A group is a car wash package that includes exactly one of the car wash programs and any combination of options. For example, a "Works" group might include the deluxe wash program and all options available on the car wash. This "group" or package would then be available using a single key on the cashier keypad and would have its own pricing structure and accounting information. As with all car wash functions, the group washes can be renamed to match your nomenclature (see Section 4.14.1).

To configure a group scroll through the configuration secondary menu until "Configure a Group" is displayed and then press the [ENTER] key. You will then be prompted for the group number (i.e.. 1 through 5 if five groups are available). Enter the number of the group to be configured using the numbers printed on the management keypad followed by the [ENTER] key (do not use the actual group key from the cashier keypad).

You will then be prompted to issue the wash type of this group. Issue the desired wash using the cashier keys as in a normal car wash transaction. For example, press the [Program 1] key, [Option 1] key, [Option 2] key and then the [ENTER] key. Once the car wash type is entered, a group ticket will be printed to confirm your selection. If an invalid set of features is entered, the console will display "INVALID SELECTION" and wait for a valid set of features to be issued.

**Note:**

A carwash "group" cannot be used as a feature to configure another group, use only specific wash programs and options.

Example to set Group 3 to Program 1 and options 1, 2 & 4:

```
[CMD]
[SYSTEM SETUP]
[3]                (password 3)
[ENTER]
[MENU UP/DOWN] until "Configure a Group" is displayed
[ENTER]
[3]                (select group #3 to configure)
[ENTER]
[Prog 1]           (select wash functions in group)
[Opt 1]
[Opt 2]
[Opt 4]
[ENTER]
```

4.1.3 Set Code Age Warning

This command allows you to change the code age warning message printed on customer tickets. Unitec recommends that this be left at the factory default setting of '0' which will cause no code age warning to be printed on the ticket. The code age value may also be used by the Convenience Store POS System and Pump for printing code age warnings on customer receipts. Because the code age warning printed at the store POS and pump is controlled by the store POS system, Customers should contact their POS supplier or distributor for guidance in configuring the POS system for this message.

Should the Operator choose to provide a code age warning message on receipts, the procedure is as follows:

Scroll through the configuration secondary menu until "Set Code Age Warning" is displayed and press the [ENTER] key.

Once selected, you will be prompted to Enter # of Days Good. The default value should be 0 (no message will be printed on customer tickets). Enter the value for number of days to use in the code age warning message. If 1 is entered, the message will be "Code is Good One Time Today Only". If a number between 1 and 30 is entered, the message will be "Good Once During Next # Days".

Note that with a multiple-console configuration, when code age is changed on the master console, it is immediately downloaded to the remote consoles.

**Important:**

Carwash codes are NOT automatically removed from memory when this time expires and they will still be usable. If you wish to enforce the code age warning, you must use the Memory Information/Clear Old Codes command

4.1.4 Set Code Length

This command allows you to change the maximum number of digits used in codes. Larger customer codes reduce the probability of a jackpotting of the system by guessing random numbers. For example, if the valid codes database is filled with 5,000 carwash codes and the code length is set to 6 (maximum code is 999990) a 10% probability of jackpotting exists, or 10 random codes would have to be tried on average to jackpot the system. With the same 5,000 valid codes but a maximum code length of 7 (maximum code is 9999990) a 1% probability of jackpotting exists, or 100 random codes would have to be tried on average to jackpot the system. Note that with a multiple-console configuration, when code length is changed on the master console, it is immediately downloaded to the remote consoles.

To select this command scroll through the System Configuration secondary menu until "Set Code Length" is displayed and press the [ENTER] key. Once selected, the console prompts you to enter the maximum code length as 5, 6, or 7. Press 5, 6 or 7 as desired followed by the [ENTER] key.

Example to set code length to 6 digits:

```
[CMD]
[SYSTEM SETUP]
[3]                (password 3)
[ENTER]
[MENU UP/DOWN] until "Set Code Length" is displayed
[ENTER]
[6]
[ENTER]
```



Note: The code length includes the digit 0, which is always the last digit in a code.



Important:

Setting the code length to 5 digits will result in reducing the number of valid codes stored in memory from 5000 to 3000. This is necessary since there is a limited number of 5 digit codes. If there are already more than 3000 codes in memory, you must delete enough old codes to reduce the number in memory to fewer than 3000 or delete all valid codes.

4.1.5 Disable Cashier Keys

This command allows you to disable specific cashier keys. If a key is disabled, it cannot be sold as part of a customer transaction. All cashier keys for features that are not available on the particular carwash installation should be disabled. This prevents a cashier from selling features that are not available and is critical if you have the automatic buy up feature that allows customers to upgrade or pay cash for a wash at the carwash entrance.

To select this command, scroll through the system configuration secondary menu until "Disable Cashier Key" is display and press the [ENTER] key. Once selected you will be prompted **Press Cashier Keys to Disable, Then ENTER**. Press all cashier keys that should be disabled and then press the [ENTER] key. To enable all cashier keys, press only the [ENTER] key.

For example, if you have a console with 4 programs, 4 options and 4 groups and you don't use group 4 and the carwash doesn't have program 4 or options 3 and 4, you disable the unused keys as follows:

```
[CMD]
[SYSTEM SETUP]
[3]                (password 3)
[ENTER]
[MENU UP/DOWN] until "Disable Cashier Key" is displayed
[ENTER]
[Prog 4]           (disable program 4)
[Opt 3]            (disable option 3)
[Opt 4]            (disable option 4)
[Group 4]          (disable group 4)
[ENTER]
```

Example to re-enable all cashier keys:

```
[CMD]
[SYSTEM SETUP]
[3]                (password 3)
[ENTER]
[MENU UP/DOWN] until "Disable Cashier Key" is displayed
[ENTER]
[ENTER]            (no cashier keys pressed)
```

 **Note:** Cashier keys that have been disabled MUST be re-enabled using the above steps.

 **Note:** All programs and options not available on your particular carwash and all group packages not programmed and used by you must be disabled if the buy up option is enabled.

4.1.6 Set Serial Baud Rate

This command allows you to change the serial baud rate of the cash register port on the console. This rate only needs to be changed if you are connecting to an External Point of sale device.

To select this command scroll through the configuration secondary menu until "Set Serial Baud" is displayed and then press the [ENTER] key. You will then be prompted to enter the new baud rate. Only standard baud rates are allowed: 1200, and 2400, 4800, 9600, and 19200. If you enter one of these rates, it will be saved. If you enter any other rate, an error message is displayed and the baud rate is not changed.

Example for setting the baud rate to 9600:

```
[CMD]
[SYSTEM SETUP]
[MENU UP/DOWN] until "Set Baud Rate" appears
[ENTER]
[9][6][0][0]
[ENTER]
```

	Note:	The new Baud Rate will not take effect until a power reset of the console occurs. To do this, simply turn the ON/OFF switch in the OFF position for a moment and then return it to the ON position.
---	--------------	---

	Note:	The factory default baud rate is dependent on what type of EXT POS interface is configured on default. Serial Baud default for POS1 & POS2 is 19200, serial baud for POS 0 (No EXT POS interface) and POS3 is 2400.
---	--------------	---

4.1.7 Set Languages

This command allows you to change the language used on the main console display and/or the customer language (used on tickets and optional customer display at entrance of wash). To select this command scroll through the system configuration main menu until "Set Language" appears and then press [ENTER].

Once selected you are prompted to enter the desired console language. Press [0][ENTER] for English or [1][ENTER] for French. Next, you are prompted to select the customer language in a similar manner.

Example to set console language as English and the customer language as German:

```
[CMD]
[SYSTEM SETUP]
[3]           (password 3)
[MENU UP/DOWN] until "Set Languages" appears
[ENTER]
[0]           for English
[ENTER]
[2]           for German
[ENTER]
```

4.1.8 Set Program Relays

This command is only available on systems configured for a specific manufacturer. If a section titled "OUTPUT Logic Block" does not appear on your SYSTEM CONFIGURATION report then this option is not available on your system.

This command allows the output relays on the customer interface board to be configured for Logic and Block values that correspond to each carwash program. To select this command, scroll through the system configuration secondary menu until "Set Program Relays" is display and press the [ENTER] key.

Once this item is selected, you will be prompted to **Enter Program Number**. Use the numbers printed on the management keys to select the number of the program you wish to configure (do not use the cashier keys) and then press [ENTER]. Next you will be prompted to **Enter Logic & Block**. Again, use the management keys to enter the appropriate value. If you enter and invalid logic or block value, the console will display the message "Invalid Logic/Block" and the command will be terminated.

Example to configure Program 1 to have a logic & block value of 32:

```
[CMD]
[SYSTEM SETUP]
[3]           (password 3)
[MENU UP/DOWN] until "Set Program Relays" appears
[ENTER]
```

[1]
 [ENTER]
 [3][2]
 [ENTER]

4.1.9 Cash Upgrades (Options) Menu

This sub-menu is used to configure the cash upgrade or buy up capabilities of your system. It contains three sub-menu items:

- Set BUYUP Mode
- Set Coin/Bill Values
- Set Dispense Value
- Set Dispense Mode (E-systems 4000 only)

To execute one of the sub-menu commands, first select "Cash Upgrades MENU->" from the SYSTEM SETUP menu. Next, scroll through the sub-menu until the command of interest is displayed and then press the [ENTER] key.

4.1.9.1 Set BUYUP Mode

This command is used to enable or disable buy up capability at the entrance of the carwash. To select this command, scroll through the Cash Upgrades sub-menu until "Set BUYUP Mode" appears and then press [ENTER].

There are two buy up modes that are generally available:

- 0: No upgrade/upgrade capability
- 1: Automatic by price

In addition for E-systems 4000 units :

- 2: Forced selection

If your carwash supports other modes, those options will appear as choices when the command is executed.

Example to disable buy ups:

```
[CMD]
[SYSTEM SETUP]
[3] (password 3)
[MENU UP/DOWN] until "Cash Upgrades MENU ->" appears
[ENTER]
[MENU UP/DOWN] until "Set BUYUP Mode" appears
[ENTER]
[0]
[ENTER]
```



Note:

The default buy up mode depends upon the carwash your POS4000 is configured to operate with.

4.1.1.9.2 Set Coin/Bill Values

This command is used to set the value of the coin and bill pulses that are connected to the interface board at the entrance of the carwash. To select this command scroll through the Cash Upgrades sub-menu until "Set Coin/Bill Values" appears and then press [ENTER].

Example to set coins as \$0.50 and bills as \$5.00:

```
[CMD]
[SYSTEM SETUP]
[3] (password 3)
[MENU UP/DOWN] until "Cash Upgrades MENU ->" appears
[ENTER]
[MENU UP/DOWN] until "Set Coin/Bill Values" appears
[ENTER]
[5][0]
[ENTER]
[5][0][0]
[ENTER]
```



Note: The default buy up mode depends upon the carwash your POS4000 is configured to operate with



Caution: This command is NOT available on systems configured to work with the Hamilton Autotec.

4.1.1.9.3 Set Dispense Value

This command is used to set the value of coins that are dispensed as change by the AUTOTEC or the E-Systems 4000 at the entrance of the carwash. Unless your POS4000 main console is used with the Hamilton AutoTec or the Unitec E-4000, this command will have NO effect upon the operation of your system. To select this command scroll through the Cash Upgrades sub-menu until "Set Dispense Value" appears and then press [ENTER].

Example to set the value of dispensed coins as \$1.00:

```
[CMD]
[SYSTEM SETUP]
[3] (password 3)
[MENU UP/DOWN] until "Cash Upgrades MENU ->" appears
[ENTER]
[MENU UP/DOWN] until "Set Dispense Value" appears
[ENTER]
[1][0][0]
[ENTER]
```



Note: The default value is \$0.25. Valid values are 25, 50, 100, and 200.

4.1.1.9.4 Set Dispense Mode (E-System 4000 only)

This command is used to set criteria for when the E-System 4000 coin box will dispense change. This function will not affect the change making ability for a Hamilton Autotec. The dispense modes are defined as follows:

Table 13. E-System Dispense Mode

Dispense Mode	Description	Comments
0	No change available	None
1	Change available after wash activated	<p>Change is available at the escrowed amount only. If the amount entered is equal to the value of a wash (the wash armed) then the amount will not be refunded. Only the amount between the wash prices is refunded.</p> <p>Example: If wash prices are \$3.00, \$4.00, and \$5.00, and the customer enters \$3.50 (\$3.00 wash is armed) then selects the refund button, then only the \$.50 is refunded.</p> <p>Refunding is disabled until the customer has armed a wash.</p>
2	Change available before wash activated.	<p>This is the same as with mode 1 except that the refund is available before a wash is activated also.</p> <p>Note: if the system is prompting the customer to make a wash selection, refunding will not be available.</p>

4.1.1.10 External POS MENU->

	<p>Note: This command is used to configure an OPTIONAL FEATURE of the POS4000. If this feature is not present in your system, you will not be able to execute these commands.</p>
---	--

This sub-menu is used to configure the external Point-of-Sale (POS) capabilities of your system. It contains the following sub-menu items:

- Set POS Offset (direction and amount)
- Set EXT. POS Type
- Set POS MAX WASHES (for special circumstances only)
- Set Send Code age (for certain EXTPOS units only)
- Set Reverse order (to allow pumps to have wash 1 most expensive)
- Set Default Discounts

To execute one of the sub-menu commands, first select "External POS MENU->" from the SYSTEM SETUP menu, and then scroll through the sub-menu until the command of interest is displayed and then press the [ENTER] key.

Note that with the Optional Remote Extpos Connection Software, the master and each secondary console can be set to interface to a different External POS system using different configuration settings.

4.1.10.1 Set POS Offset



Note: This feature is for use with POS 1, 2 and 3.

This command is used to convert an external POS system's wash "type" or "level" to a POS4000 program or group key.

To select this command, scroll through the External POS sub-menu until "Set POS Offset" appears and then press [ENTER].

Example to set the POS Offset as 5 UP:

```
[CMD]
[SYSTEM SETUP]
[3]          (password 3)
[MENU UP/DOWN] until "External POS MENU->" appears
[ENTER]
[MENU UP/DOWN] until "Set POS Offset" appears
[ENTER]
[1][ENTER]   to select direction UP
[5][ENTER]   to select amount of offset as 5
```



Note: The default is for there to be no offset (i.e. 0 down).



Note: The current EXT POS settings will print out with a mapping of the carwash type given vs. the carwash type requested.

4.1.10.2 Define External POS Type

This command is used to define what type of external Point-of-Sale equipment is present and connected to the POS4000. To select this command, scroll through the External POS sub-menu until "Define EXT. POS Type" appears and then press [ENTER].

Example to set the external POS type as 3:

```
[CMD]
[SYSTEM SETUP]
[3]          (password 3)
[MENU UP/DOWN] until "External POS MENU->" appears
[ENTER]
[MENU UP/DOWN] until "Define EXT. POS Type" appears
[ENTER]
```

[3][ENTER]

 **Note:** If the external POS type is set to 1 or 2, the current EXT POS settings will print out with a mapping of the Carwash type given vs. the carwash type requested.

4.1.10.3 Set POS MAX WASHES

 **Note:** This feature is for use with POS 1 and 2 only.

This function is used to modify the commands received by an external point of sale device such as pump equipment. These commands are configured to ask for more wash types than are available. You should only change this value when instructed to do so from an application note or a Unitec service technician. The default value is 0 (disabled). This value only limits the number of wash types that can be requested by an External POS device, not the number of wash types that can be sold via the console or entry system (cash or buy ups).

Example to set the POS MAX WASHES to 3 (max of 3 washes allowed):

```
[CMD]
[SYSTEM SETUP]
[3] (password 3)
[MENU UP/DOWN] until "External POS MENU->" appears
[ENTER]
[MENU UP/DOWN] until "Set POS MAX WASHES" appears
[ENTER]
[3][ENTER] to select maximum of 3 wash types to be given
```

 **Note:** The current EXT POS settings will print out with a mapping of the carwash type given vs. the carwash type requested.

4.1.10.4 Set Send Code Age

This command is used to enable the POS1 or POS2 protocol to include the response code for code age and wash status. In some cases when this feature is not enabled (default) the receipt printed out at the gas pump will show that the code is valid for 1 day only. Enabling this value may cause the system to not work properly with some point of sale manufacturers. To select this command, scroll through the External POS sub-menu until "Set Send Code Age" appears and then press the indicated function key.

Example to set send code age enabled:

```
[CMD] to select command mode
[2-System Setup] to select "System Setup" menu
[3] Enter your password 3
[ENTER]
[Menu up] Until you see: "Ext. POS MENU->"
[Menu up] Until you see "Set Send Code Age"
[Enter] Select function
[ 1 ] To enable set send code age
```

[ENTER]



Note: The default setting is 0, which is normal protocol.

4.1.10.5 Reverse Order



Note: This feature is for use with POS 1 and 2 only.

Enabling the Reverse Order function will allow the order of carwashes configured in the External POS device to be reversed. This function is often used when the External POS has the prices configured in descending order (wash 1 on EXTPOS is most expensive). Since the wash prices for an entry system that uses cash must be in ascending order at the POS4000, this function allows the re-mapping of the washes requested at the registers and pumps. This function must be configured w/ POS MAX WASHES to determine how to reverse the order.

Example:

Carwash is configured w/ 3 washes:

- Wash 1 (program 1): Basic \$4.00
- Wash 2 (program 2): Deluxe \$5.00
- Wash 3 (program 3): Supreme \$6.00

Register is configured to the opposite:

- Wash 1 : Supreme \$6.00
- Wash 2 : Deluxe \$5.00
- Wash 3 : Basic \$4.00

To make the system function properly you must configure POS MAX washes (See Section 4.1.10) to a value of 3 (3 washes). Set Reverse order to 1 (enabled).

After changing these values the current EXT POS settings will print out with a mapping of the Carwash type given vs. the carwash type requested. This will show the relationship of the mapping.

If you use groups, you must also set the POS OFFSET (Se Section 6.2.10.1).

This function only works with POS 1 & POS 2.

Example to set Reverse order to Enabled:

[CMD]	to select command mode
[2-System Setup]	to select "System Setup" menu
[3]	Enter your password 3
[ENTER]	
[Menu up]	Until you see: "Ext. POS MENU->"
[Menu up]	Until you see "Reverse order"
[Enter]	Select function

[1][Enter] To enable select 1

4.1.10.6 Set Default Discount Levels



Note: This feature is for use with POS 1, 2 and 3.

Setting the default discount levels of the EXTPOS washes will make it so that when the EXTPOS wash is requesting a code, the accounting will assign a specific discount level to the purchase. This will happen even though the EXT POS device does not tell the POS4000 the discount level at which the wash was sold. This feature can only be accomplished C-store register systems that can do the following:

Allow washes to be sold at pump or register only

Allow the configuration of 6 or more discrete wash types (depending on the discount levels you need to implement the register may have to accommodate up to 12 wash types)

Whenever this function is accessed, a report will print out to show the mapping of the washes.

Example:

EXT POS will be set up for 12 washes. Carwash has 4 real washes. EXT POS washes are defined as:

Wash 1-4: Discounted washes 1-4 sold at pumps and in C-store

Wash 5-8: Full price washes 1-4 sold in C-store only

Wash 9-12: Free (rewash) washes 1-4 sold in C-store only

Example configuration process:

Set prices in POS4000 for washes 1-4 (don't forget Discount levels)

Enable reverse ordering if required

Set POS MAX Washes value to 4

[CMD]	to select command mode
[2-System Setup]	to select "System Setup" menu
[3]	Enter your password 3
[ENTER]	
[Menu up]	Until you see: "Ext. POS MENU->"
[Menu up]	Until you see "Set Default Discnts"
[Enter]	Select function
[1][Enter]	To set EXT POS wash 1 to discount 1
[1][Enter]	To set EXT POS wash 2 to discount 1
[1][Enter]	To set EXT POS wash 3 to discount 1
[1][Enter]	To set EXT POS wash 4 to discount 1
[0][Enter]	To set EXT POS wash 5 to discount 0
[0][Enter]	To set EXT POS wash 6 to discount 0
[0][Enter]	To set EXT POS wash 7 to discount 0
[0][Enter]	To set EXT POS wash 8 to discount 0
[2][Enter]	To set EXT POS wash 9 to discount 2
[2][Enter]	To set EXT POS wash 10 to discount 2
[2][Enter]	To set EXT POS wash 11 to discount 2
[2][Enter]	To set EXT POS wash 11 to discount 2

4.1.11 Multiple Unit MENU->

**Note:**

This command is used to configure an OPTIONAL FEATURE of the POS4000. If this feature is not present in your system, you will not be able to execute these commands.

This sub-menu is used to configure the multiple customer interfaces (carwash) and multiple Point-of-Sale (POS) capabilities of your system. It contains 4 sub-menu items:

- Set Unit Number
- Controller/Remote
- Set # Bays/Consoles
- Prog Remote Consoles

To execute one of the sub-menu commands, first select "Multiple Unit MENU->" from the SYSTEM SETUP menu, and then scroll through the sub-menu until the command of interest is displayed and then press the [ENTER] key.

4.1.11.1 Set Unit Number

This command is used to set the unit number of the POS4000.

To select this command, scroll through the Multiple Unit sub-menu until "Set Unit Number" appears and then press [ENTER].

Example to set the unit number of a POS4000 as 3:

```
[CMD]
[SYSTEM SETUP]
[3] (password 3)
[MENU UP/DOWN] until "Multiple Unit MENU->" appears

[ENTER]
[MENU UP/DOWN] until "Set Unit Number" appears
[ENTER]
[3]
[ENTER]
```

**Note:**

The default unit number is 1.

4.1.11.2 Controller/Remote

This command is used to designate a POS4000 main console as either a controller console or a remote console.

To select this command, scroll through the Multiple Unit sub-menu until "Controller/Remote" appears and then press [ENTER].

Example to designate a main console as a REMOTE Console:

```
[CMD]
[SYSTEM SETUP]
```

```
[3] (password 3)
[MENU UP/DOWN] until "Multiple Unit MENU->" appears
[ENTER]
[MENU UP/DOWN] until "Controller/Remote" appears
[ENTER]
[2] to select Remote
[ENTER]
```



Note: The default is for the console unit to be a controller.

4.1.11.3 Set Number of Bays and Consoles

This command is used to define the number of customer interfaces (carwash bays) and remote POS4000s that are present at a site.



Note: Do not include the controller POS4000 when counting the number of Remote POS4000s.

To select this command, scroll through the Multiple Unit sub-menu until "Set # Bays/Consoles" appears and then press [ENTER].

Example to setup a controller console to communicate with 2 customer interfaces and 1 remote POS4000:

```
[CMD]
[SYSTEM SETUP]
[3] (password 3)
[MENU UP/DOWN] until "Multiple Unit MENU->" appears
[ENTER]
[MENU UP/DOWN] until "Set # Bays/Consoles" appears
[ENTER]
[2][ENTER] 2 bays
[1][ENTER] 1 remote console
```



Note: The default is 1 bay and 0 remote consoles.



Note: When setting up a remote console, # of remote consoles is always set to 0.

4.1.11.4 Program Remote Consoles

This command is used to program or download information from the controller POS4000 to remote POS4000s.

To select this command, scroll through the Multiple Unit sub-menu until "Prog Remote Consoles" appears and then press [ENTER].

Example to program remote consoles:

```
[CMD]
[SYSTEM SETUP]
[3] (password 3)
[MENU UP/DOWN] until "Multiple Unit MENU->" appears
[ENTER]
[MENU UP/DOWN] until "Prog Remote Consoles" appears
[ENTER]
```

This command will take a few moments to execute (depending upon the number of remote consoles to program). As the information is being passed to the remote console, verification messages will be displayed on the POS4000 screen. The last message to be downloaded is "ACK DWLD Tax Rate"; if you see this message displayed for more than 15 seconds, the downloading is complete. Press the **Clear** button.



Note: Do not attempt to perform any activity at any of the consoles while downloading is in progress.

4.1.12 Modem rings

This command is used to configure the number of rings that the modem will answer an outside call. This is for a POS4000 feature that is no longer supported.

4.1.13 E-System setup MENU->

This command is used to configure an E-systems coin box feature setting. If the E-systems coin box is equipped with change making or has multiple LCD displays (for each wash type) then here is where you will enable or disable the feature. This sub-menu is not usable on a Hamilton Autotec system.

4.1.13.1 Enable/Disable Change

This command is used to Enable or Disable the change-making feature of an E-System coin box. If your E-System coin box is equipped with change making capability, then you want to have Change Enabled.

Example to Enable change in an E-system coin box remote consoles:

```
[CMD]
[SYSTEM SETUP]
[3] (password 3)
[MENU UP/DOWN] until "E-System setup MENU->" appears
[ENTER]
[MENU UP/DOWN] until "Enab/Disab Change" appears
[ENTER]
[1] [ENTER] Enable change
```



Note: If your system was incorrectly configured for change and you are disabling change, you must first power down and then power up the entry system before it will function properly.

4.1.13.2 Enable/Disable Displays

This command is used to Enable or Disable the wash displays feature of an E-system coin box. If your E-System coin box is equipped with multiple LCD displays (E-4000 coin box), then you want to have Displays enabled.

Example to Enable Displays in an E-system coin box remote consoles:

```
[CMD]
[SYSTEM SETUP]
[3]                (password 3)
[MENU UP/DOWN] until AE-System setup MENU->" appears
[ENTER]
[MENU UP/DOWN] until "Enab/Disab Displays" appears
[ENTER]
[1] [ENTER]       Enable Displays
```

**Note:**

If your system was incorrectly configured for multiple displays and you are disabling them, you must first power down then power up the coin box before it will function properly.

4.1.14 Relay Latching

This command is used to set the relay latching to Momentary Outputs (default), or Latched outputs. When relay latching is disabled (momentary outputs), the relays will pulse on for 1 second then all turn off once the customer enters a code or the appropriate amount of cash. The relays will then pulse on again if the customer upgrades the wash.

When the relay latching is enabled, the program relays will come on when the customer activates the wash by entering a code or cash. The relays will then stay on until a wash-in-use signal is inputted to the system, at which time the outputs will all turn off.

4.1.15 Relay Stacking

This command is used to enable relay stacking (default), disable relay stacking, or set to no customer stacking.

When relay stacking is enabled, the program relays will not activate while the wash-in-use signal is activated. The relays will wait until the wash-in-use signal is off to activate the relays.

This effectively allows the customers to enter their code or cash while the wash is in use. Once the wash is no longer in use, the appropriate wash is activated and the customer will be prompted to enter the wash.

If relay stacking is disabled, the only difference is that the program relays will be activated immediately upon a valid code entry or when the appropriate amount of cash is entered.

If No Cust Stacking is set, the customer will not be allowed to enter a code or cash into the entry system while the wash is in use. If a voice module is available in the entry system, Message 1 should be changed to "Please wait for the wash to complete before entering your code or adding cash."

4.2 Multi-Use Codes

The multi-use codes feature, also known as "bundled wash" and similar to a fleet account, is used to sell a number of uses of a particular wash at a preset price. The customer gets a single code for these uses. The price, the number of uses, the type of wash in the package, and the feature number representing this package are preset in a "template". Once a feature (wash) number is assigned to the package, the sale of a multi-use code is similar to that of a regular code, just ringing up the feature number for the package defined in the template.

No programming or setup is needed at the WSII, assuming its connection to the POS4000 is working, for it to accept the multi-use code. When a multi use code is entered, the display will show the number of uses left for the code briefly. If the print receipt option is enabled in the template, a receipt will be printed.

4.2.1 Requirements and Limitations

- The minimum version for the POS4000 is v8.20, and v5.02 for the WSII.
- The POS4000 must have high fleet feature and the WSII must NOT have enhanced fleet feature. These features are built into the EPROMs and are not programmable, so make sure to install the right firmware.
- The multi-use code is only supported at the master POS4000 if there are remote POS4000s.
- The number of codes can be sold is limited by the free fleet account spaces. The multi-use code share the account space with other fleet accounts in the POS4000, where the fleet account capacity is 1000 with high fleet feature.

4.2.2 Template Programming On the POS4000

Perform the command to access the Multi-Use Code Setup:

```
[CMD]
[SYSTEM SETUP]
[3]                (password 3)
[ENTER]
[MENU UP/DOWN] until "External POS" is displayed
[ENTER]
[MENU UP/DOWN] until "Set Multi-Use Code" is displayed
[ENTER]
```

If it shows "Menu option not available", check the EPROMs in the POS4000 and the WSII to make sure they have the correct features (see above), then check the communication between the POS4000 and the WSII. Fix the problem and try again.

Then follow these steps:

Table 14. Setting Up Multi-Use Code Feature

Display	Action
Multi-use codes Allowed?	Press 1, then Enter
Enter Account Name	Give a name to the multi-use code, then press Enter

The Feature Requested by EXT POS	Enter the feature (wash) number representing this package, then press Enter
Wash # sold in the package	Enter the number of the wash to be sold in the package, then press Enter
Max # of uses per package	Enter the number of uses in the package, then press Enter
Total package price (in cents)?	Enter the price of the package in cents, then press Enter
Print code status?	Enter 1 if a receipt is printed at the WSII on each use, or enter 3 for no receipt, then press Enter

After these steps, the template is saved and printed.

4.2.3 Selling a Multi-use Code on the External POS

Ring up a wash with the feature number programmed in the template to start the sale. The code issued can be used as many times as the number of uses programmed in the template.

4.3 Fleet Account Management

This command allows you to establish and maintain fleet accounts. A fleet account allows you to establish a customer code that can be used multiple times by a fleet account customer. Each time a fleet account is used, accounting information is stored and an account usage receipt is optionally printed at the main console printer.

To select the fleet account command press the [CMD] key followed by the [ACCNT INFO] key. The console will prompt you to enter password 2. Once the correct password is entered, you will see the secondary menu.

The standard secondary menu consists of the following commands:

- Print All Accounts
- Add an Account
- Delete an Account
- Print 1 Account
- Reset # of Washes

With POS4000 Software Version 7.9 or above and WSII Software Version 4.20 or above (for combined WSII/POS4000 systems with the Enhanced Fleet Option only), Fleet Account information is stored in the WSII. With this software, you have the ability to manage all Fleet Accounts at the POS4000 the same way you would at the WSII, including managing VIP Wash Cards.

When you open the Account Info at the POS4000, you will see the following secondary menu:

- Add Account
- Edit Account
- Add to an Account
- Delete Account

- Print Account
- Print All Accounts
- Print Trans History
- Delete All Empty
- Erase All Accounts

To execute one of the secondary commands, scroll through the secondary menu until the command of interest is displayed, and then press the [ENTER] key.

The procedures for using these commands are identical to the procedures used at the WSII. Refer to the *WSII POS Operations Manual* “**Fleet Accounts and Coupons**” section for more information on these commands.

4.3.1 Print Current Information of All Accounts

To print information on all existing accounts, scroll through the fleet account secondary menu until "Print All Accounts" is displayed then press the [ENTER] key. The following information will be printed for all current fleet accounts:

- Account code
- Account name
- Date and time account was opened
- Maximum number of washes
- Number of uses to date
- Receipt printed or NOT printed
- Wash type
- Unit price of wash

Example:

```
[CMD]
[ACCOUNT INFO]
[2] (password 2)
[MENU UP/DOWN] until "Print All Accounts" appears
[ENTER]
```

4.3.2 Add an Account

To add an account, scroll through the fleet account secondary menu until "Add an Account" is displayed and then press the [ENTER] key.

You will be prompted first for the **Account Name**. The account name can be up to 20 characters long and is entered using the alphanumeric characters on the keys followed by the [ENTER] key.

You are then prompted for the **Account Code**. This code will be given to the customer and used to activate the car wash. Account codes cannot be longer than 9 digits, must end in a 0 and must NOT contain a 0 anywhere else in the code. If a car wash code or fleet account with this number

already exists, you will be prompted to "Try Again". If this happens, simply type in a different code and press [ENTER] again.

Next you will be prompted for the **Maximum number Washes**. This is the total number of times this code can be used. For example, if you type 100 followed by the [ENTER] key, the code will be good for 100 washes.

Next you will be prompted to input the **Price Per Wash**. This price is the amount that the customer will owe for each use of the code. If the customer is paying for the washes at the time the account is established, the price would be set at 0. The price is entered in cents. For example, a \$2.50 wash would be entered as '250' followed by the [ENTER] key.

Next, the console will display **Print when Used?** This item controls whether or not a receipt will be printed each time the account code is used. If you want a receipt to be printed when the account code is used press [1] then [ENTER], if you do not want a receipt printed when the account code is used press [0] then [ENTER].

Finally, you will be prompted to **Issue Wash Type**. This defines the features for which the fleet account code will be valid. At this point, issue a car wash as you would during a normal car wash purchase using the cashier keys. Note that you cannot use a car wash "group" in an account. Once all the carwash features are selected, press the [ENTER] key. If an invalid set of features has been selected, the console will display the message "INVALID SELECTION". At this point, you should re-enter a valid set of features. Once a valid selection is made, the account information will be printed concluding the transaction. This receipt is for the account customer's use.

The car wash pricing information entered when establishing an account is only recorded with the account information. This pricing will be printed each time account information is printed but it is not used in any of the shift report cash totals. Cash accounting for the accounts must be performed by reviewing account receipts or printing information for 1 or all accounts.



Note: It is recommended that account codes be at least 6 digits to minimize the possibility of someone "jackpotting" an account.

Example to create a fleet account with code 1234560 valid for Program 1 + Option 1 + Option 3:

```
[CMD]
[ACCOUNT INFO]
[2]                (password 2)
[ENTER]
[MENU UP/DOWN] until "Add an Account" is displayed
[ENTER]
[A][B][C][ ][T][A][X][I][S]
[ENTER]
[1][2][3][4][5][6]    (account code, 0 is optional)
[ENTER]
[4][5]                (the code is valid 45 times)
[ENTER]
[3][5][0]            ($3.50 value for each use of code)
[ENTER]
[Prog 1]              (account wash selection)
[Opt 1]
[Opt 3]
[ENTER]
```

4.3.3 Delete an Account

To delete a specific fleet account, scroll through the fleet account secondary menu until "Delete an Account" is displayed and then press the [ENTER] key. You will then be prompted for a fleet account code. If a valid fleet account code is entered, the current account information will be printed and then the account will be deleted.

Example to delete account 1234560:

```
[CMD]
[ACCOUNT INFO]
[2]                (password 2)
[ENTER]
[MENU UP/DOWN] until "Delete an Account" is displayed
[ENTER]
[1][2][3][4][5][6]    (account to delete, 0 is optional)
[ENTER]
```

4.3.4 Print Information on a Specific Account

To print account information on a single account scroll through the fleet accounts secondary menu until "Print 1 Account" is displayed then press the [ENTER] key. Once this is selected, you will be prompted for a fleet account code. If a valid fleet account code is entered, the information for that account will be printed.

Example to print information for account code 1234560:

```
[CMD]
[ACCOUNT INFO]
[2]                (password 2)
[ENTER]
[MENU UP/DOWN] until "Print 1 Account" is displayed
[ENTER]
[1][2][3][4][5][6]    (account code 123456)
[ENTER]
```

4.3.5 Reset Number of Washes for an Existing Account

The maximum number of washes available for an account can be reset by scrolling through the fleet account secondary menu until "Reset # Washes" is displayed and then pressing the [ENTER] key. Once selected, the console will prompt for the fleet account code. If a valid fleet account code is entered, the console will first print the status of that fleet account. The console will then prompt for the **New # of Washes**. When entered, the previous maximum number of uses will be reset to the new # of washes, the number of uses to date will be cleared and the updated account information will be printed.



Note:

This function clears the previous number of remaining uses of an account. As such, you must account for the unused value of this account when you reset the number of uses.

Example to change number of washes to 30 for account 1234560:

```
[CMD]
[ACCOUNT INFO]
[2]                (password 2)
[ENTER]
[MENU UP/DOWN] until "Reset # of Washes" is displayed
```

```
[ENTER]
[1][2][3][4][5][6]      (account code 123456)
[ENTER]
[3][0]                    (make account good for 30 washes)
[ENTER]
```

4.3.6 Delete Empty Accounts

This new feature added in Version 6.64 is used to delete the fleet accounts in memory that have used up their available washes. This can be used to clear out some of the fleet account memory when filled up. The fleet accounts deleted will print up as if you selectively deleted each account as with the Delete and Account command.

Example to delete empty accounts:

```
[CMD]
[ACCNOUNT INFO]
[2]                        (password 2)
[ENTER]
[MENU UP/DOWN] until "Delete Empty accounts" is displayed
[ENTER]
[1]                        (Yes to delete empty accounts)
[ENTER]
```

4.4 Accounting Report



Note: All accounting reports are mutually exclusive, meaning you can clear any level (excluding the non-resettables) without affecting the other levels.

4.4.1 POS4000 Accounting Report

Depending on your particular setup, an accounting report may include the following information:

- **DATE AND TIME OF REPORT**
- **REPORT HEADING** - Defines counter levels of the report (either Manager/Shift or Non-resettable/Auditor)
- **DETAILED SALES AND USAGE COUNTS FOR EACH FEATURE**
 - Feature Label Code sales at each price level (Regular, Discnt1 and Discnt 2)
 - Codes used
 - Backup codes used - For these codes to be used, the interface board must have been placed in the backup mode (see Section 8).
 - Fleet account codes used
 - If buy up capability is enabled, a dashed line is printed and then wash activation information is provided:
 - # of washes activated with code only
 - # of washes activated with cash only
 - # of washes activated with a code (valid for a lower priced program) and cash

- Sub-total of how many times each feature was activated



Note: The counts for a particular item are, in general, printed only if the count for at least one of the levels is non-zero. This "auto-condensing" feature makes the reports easier to read since extraneous data is not printed.

- **VEHICLES WASHED SUMMARY-** Summarizes the sub-totals from the detailed usage counts
- **WASH TIME INFO M:SS** - This section indicates the number of times the car wash was "in-use" for specific time amounts. For example, a count of 50 in the 1:00-2:30 duration indicates that 50 washes were used that lasted between 1 minute and 2 minutes 30 seconds. This information is derived from the wash in-use signal; therefore numbers may not be equal to the Vehicles Washed Summary if washes are activated by bypassing the interface board.
- **AUDIT INFORMATION** - (typically not used) This section contains information about the auxiliary counters that are located on the customer interface board. These counters can be used to count a variety of external events such as coins or tokens inserted at the entry system. The specific use of the counters is dependent on the particular installation.
- **POWER OFF INFO. H:MM** - This count indicates the number of times the main console has been powered off for several specific time amounts. For example, a count of 10 in the 1:00-6:00 duration indicates that the main console has been turned off 10 times for 1 to 6 hours each time. This count can be used to determine if someone is trying to defeat the security of the system by turning the power off.
- **COMMAND USAGE COUNTS** - This section indicates the number of times each type of command has been used.
- **PASSWORD FAILURES** - This section documents the number of times each password has been entered incorrectly. This can be used to flag possible tampering with the main console.
- **CODE ENTRY ERRORS** - This count indicates the number of times an invalid code was entered at the car wash entrance. This information can help raise suspicions that somebody has been attempting to "jackpot" the system.
- **RAINCHECKS** - This count indicates the number of times a rain check has been issued.
- **CODES VOID** - This count indicates the number of customer codes that have been voided at the main console.
- **REGISTER SUMMARY** - details the following items:
 - Register Sales: total value of all codes generated



Note: The register sales counts do not include any entry system sales or fleet account sales.

- Tax on Sales: total value of tax collected
- Sales Refunds: total value of codes that have been voided
- Tax Refunds: total value of taxes from voided codes
- Net Register = 1 + 2 - 3 - 4

- **ENTRY SYSTEM SUMMARY** (if BUYUP option present) details the following items:
 - Cash Deposited: total value of cash deposited
 - Cash Dispensed: total value of cash dispensed
 - Net Cash: cash deposited minus cash dispensed



Note:

The cash totals are a running sum of each cash transaction. Therefore, if the pricing structure is changed during the accounting cycle, a computation of the total cash value of transactions indicated on the account report made using the counters and current prices will not necessarily agree with the total cash sales value.

For example: assume the account report is cleared, one program 1 wash is issued at \$1 and then the price is changed to \$2 and another program 1 is issued at \$2. The accounting report would indicate that two program 1 washes were issued and that the current price of program 1 is \$2 while the cash total would be \$3 (the correct amount).

- Overpayments: Overpayments occur when a customer enters the wash after depositing some cash, but not enough to purchase the next feature. If overpayments have been refunded by the cashier, the amount refunded must be used to adjust the net register amount. This figure is already included in the Cash Deposited figure.



Note:

Overpayment refunds are not processed by the main console and therefore NO adjustment is made for entry system overpayments refunded. When an overpayment ticket is generated and a refund is given, the ticket should be signed by the customer and cashier and used to reconcile the register.

- Quarters: number of quarters that customers have entered
 - Bills: number of bills that customers have entered
 - Token Coins: number of token coins that customers have entered
 - VIP Coupons: number of VIP coupon notes that customers have entered
 - Credit Wash: number of washes purchased that involved Credit, Debit, or RFID
- **COUNTS CLEARED** - Number of times counts have been cleared
 - Last Cleared: Time/date that counts were last cleared

Note: This command DOES NOT clear the account.



SAMPLE REPORT

POS4000 REPORT		
Print Audit Accounts 1/12/2010 02:48PM		
	MANAGER	SHIFT
PROGRAM 1		
Regular \$2.50	45	23
Discnt 1 \$1.50	4	0
Discnt 2 \$0.00	8	3
Codes Used	40	21
Accounts Used	2	2

Code Only	32	18
Cash Only	14	9
Sub-total	46	27
PROGRAM 2		
Regular \$2.50	5	3
Codes Used	5	3

Code Only	3	3
Cash Only	5	1
Code + Cash	7	5
Sub-total	15	9
VEHICLES WASHED SUMMARY		
Code Only	73	42
Cash Only	42	19
Code + Cash	58	33
Total Washes	173	94

*Print or Clear counts
Date & Time of report*

*Levels of this report
The following information is repeated for each wash type:
of codes sold at each price level*

*# of PROGRAM 1 codes used
of PROGRAM 1 Fleet account codes used*

*Entries below are actual washes activated:
activated with code only (i.e. no cash)
activated with cash only (i.e. no code)
Total # of PROGRAM 1 washes activated.*

No discount sales were made and no fleet account codes were used for PROG 2

*Lower value code and cash were used
Total # of PROGRAM 2 washes activated*

*Sum of all Code Only washes
Sum of all Cash Only washes
Sum of all Code + Cash washes
Total of all washes*

NOTES:

Entries above the dashed line represent code sales and usage. In systems that allow the customer to purchase a wash with cash or buy up from a code, the code usage counts cannot be used to determine how many of each type of wash were activated. This level of detail is given by the entries below the dashed line.

The lowest priced wash (PROGRAM 1) cannot be activated as a Code + Cash wash.

Any entry that has a count of 0 for both shift levels will not appear in the report (i.e. PROGRAM 2 discount code sales above).

In this example, the VEHICLES WASHED SUMMARY is not intended to balance with the partial report of the wash programs above.



4.4.2 POS4000-WSII Accounting Report

This section details the references in the POS4000 report to Sales at the Wash Select II software. This report will be available at a connecting POS4000 console when the POS4000 has Wash Select II software installed. To get more detailed information about the transactions at the Wash Select II, print an accounting report at the Wash Select II unit or acquire the report over the Remote Reporting option of the Wash Select II. The POS4000 report does not contain the exact same information that the Wash Select II report does.

Sample POS4000 Manager/Shift Report when connected to a Wash Select II:

Print Audit Counts
05/30/1991 10:10PM

CODE SALES/USAGE and WASH ACTIVATION SUMMARY	MANAGER	SHIFT	
EXPRESS WASH			
Regular \$ 4.00	13	8	
Discnt 1 \$ 0.00	0	0	
Discnt 2 \$ 0.00	0	0	
Codes Used	7	3	<i>POS4000 codes used at WSII</i>
Accounts Used	0	0	<i>POS4000 fleet account codes uses at WSII</i>

POSCode Only	6	2	<i>Transactions at the WII that involved only a POS4000 code.</i>
Coinbox Only	5	5	<i>Transactions at the WSII that involved any form of payment not including a POS4000 code (Credit, cash, token, VIP coupon etc.)</i>
POSCode & Upgrd	0	0	<i>Transactions that involved both a POS4000 code and some other type of payment as an upgrade.</i>
Sub-total	11	7	
DELUX WASH			
Regular \$ 5.00	10	6	
Discnt 1 \$ 0.00	0	0	
Discnt 2 \$ 0.00	0	0	
Codes Used	3	1	
Accounts Used	0	0	

POSCode Only	3	1	
Coinbox Only	6	6	
POSCode & Upgrd	0	0	
Sub-total	9	7	



SUPER WASH

Regular \$ 6.00	11	5
Discnt 1 \$ 0.00	0	0
Discnt 2 \$ 0.00	0	0
Codes Used	5	2
Accounts Used	0	0

POSCode Only	4	1
Coinbox Only	5	5
POSCode & Upgrd		0
Sub-total	9	6

WORKS WASH

Regular \$ 7.00	8	5
Discnt 1 \$ 0.00	0	0
Discnt 2 \$ 0.00	0	0
Codes Used	1	0
Accounts Used	0	0

POSCode Only	1	0
Coinbox Only	8	8
POSCode & Upgrd	2	2
Sub-total	11	10

VEHICLES WASHED SUMMARY

POSCode Only	14	4	<i>Totals for all washes</i>
Coinbox Only	24	24	<i>Totals for all washes</i>
POSCode & Upgrd	2	2	<i>Totals for all washes</i>
Offline Wash 1	2	2	<i>Coinbox only washes that occurred while the POS4000 was not communicating to the WSII coin box or was turned off.</i>
Offline Wash 2	2	2	
Offline Wash 3	3	3	
Offline Wash 4	2	2	
Total Washes	49	39	<i>Total of all washes above.</i>

WSII FLEET INFO

WSII Fleet 1	2	2	<i>Counts for washes at WSII that were paid for by using a standard fleet code. These are also counted in Coinbox only counts.</i>
WSII Fleet 2	2	2	
WSII Fleet 3	5	5	
WSII Fleet 4	4	4	
Coupon Codes	1	1	<i>Coupon Account Codes/Cards used.</i>

COMMAND USAGE COUNTS

Fleet Accounts	0	0
Print Audit Co	17	5
Set Pricing	6	5
Service Routing	0	0
Clear Audit Co	3	0
Set Messages	0	0



Set Passwords	0	0	
Void a Code	0	0	
Memory Info.	0	0	
Check Code sta	0	0	
Code Sales Loc	0	0	
PASSWORD FAILURES			
Password 1	1	0	
Password 2	0	0	
Password 3	0	0	
Password 4	0	0	
Password 5	0	0	
CODE ENTRY ERRS	1	0	
RAINCHECKS	0	0	
CODES VOID	0	0	
REGISTER SUMMARY			
Console Sales	\$165.80	\$124.80	
EXT POS Sales	\$0.00	\$0.00	
Tax on Sales	\$3.23	\$3.23	
Sales Refunds-	\$0.00	\$0.00	
Tax Refunds -	\$0.00	\$0.00	
Net Register	\$169.03	\$128.03	
COIN BOX SUMMARY			
Cash Deposited	\$53.00	\$53.00	
Cash Dispensed	\$11.00	\$11.00	
Net Cash	\$42.00	\$42.00	
Overpayments	\$0.00	\$0.00	
Quarters:	28	28	
\$1	6	6	<i>Includes \$1 coins</i>
\$2 Bills:	0	0	
\$5 Bills:	4	4	
\$10 Bills:	2	2	
\$20 Bills:	0	0	
Token Coins:	1	1	<i>Token counts. This is the # of token input pulses. If you have multiple tokens programmed, this number will be based on the programmed token value in the Wash Select II.</i>
VIP Coupons:	4	4	<i>Number of VIP Wash Coupons</i>
Credit Wash 1:	2	2	<i>Number of transactions</i>
Credit Wash 2:	3	3	<i>involving Credit/Debit cards</i>
Credit Wash 3:	2	2	<i>or RFID (even if other payment</i>
Credit Wash 4:	5	5	<i>types were also used)</i>

POS4000 Report Item	Equivalent Item on Wash Select II POS
<p>Coinbox Only</p> <p>Note:</p> <p>If the Wash Select II activated washes while not communicating to the POS4000, some Coinbox Only transactions will appear in the Offline Wash category. Thus total Coinbox washes will be Offline Wash + Coinbox Only.</p>	<p>Sum of the all Activation transactions except for: POS Code Only and POS Code + Other</p> <p>This includes: Cash Only Credit Only Token Only Cash + Token Fleet Only Fleet + Cash Fleet + Token Fleet + Other Coupon + Cash Coupon + Credit Coupon + Token Coupon + Other VIP Coupon Only VIP Coupon + Other</p>
<p>POS Code & Upgrade</p>	<p>POS Code + Other</p>
<p>Offline Wash (1-4)</p> <p>Note:</p> <p>If the Wash Select II activated washes while not communicating to the POS4000 the Coinbox only transactions will appear in the Offline Wash category. Thus total Coinbox washes will be Offline Wash + Coinbox Only.</p>	<p>Sum of all Wash Select II non-POS4000 code related transactions that occurred while offline with POS4000.</p> <p>Example:</p> <p>Coinbox Only + Offline Wash = sum of all non POS4000 code transactions as listed above in Coinbox Only (Credit, Cash, Token etc.)</p>
<p>WSII Fleet (1-4)</p>	<p>Sum of: Fleet Only Fleet + Cash Fleet + Token Fleet + Other</p>
<p>Coupon Codes</p>	<p>Sum of: Coupon + Cash Coupon + Credit Coupon + Token Coupon + Other</p>
<p>\$1</p>	<p>Sum of \$1 coins and \$1 bills</p>

POS4000 Report Item	Equivalent Item on Wash Select II POS
Token Coins	<p>Tokens:</p> <p>Note: If you have the Multi coin option and you have multiple coins programmed. This value will be based on the number of pulses received.</p> <p>Example:</p> <p>WSII programmed as \$1 token.</p> <p>Coin acceptor programmed for \$1 token (1 pulse), \$5 token (5 pulses), and \$6 token (6 pulses).</p> <p>If you have received 10 \$5 tokens, 5 \$6 tokens and 4 \$1 tokens then the report will show 84 Token Coins This is from</p> $(10 \times 5 + 5 \times 6 + 4 \times 1 = 84)$
VIP Coupons	Sum of Coupon 1 + Coupon 2 + Coupon 3 under the VIP Wash Coupons section
Credit Wash (1-4)	Number of transactions involving Credit/Debit cards or RFID (even if other payment types were also used)

4.4.3 Print Accounting Report

This command is used to print an accounting report. Accounting information is maintained in 4 levels. Three of the levels can be cleared independently of the other levels; the fourth cannot be reset. An accounting report consists of two levels printed in adjacent columns.

To select this command, press the [CMD] key followed by the [PRINT REPORT] key. At this point, you should press [MENU UP/DOWN] until the desired report levels appear (you can print either the Shift and Manager levels or the Auditor and Non-resettable levels) and then press [ENTER].

 **Note:** This command does NOT clear the counts.

Example to print the Accounting report for the Auditor and Non-resettable levels:

```
[CMD]
[PRINT REPORT]
[MENU DOWN]
[ENTER]
```

4.5 Set Prices

This command lets you set the prices for each feature (programs, options and groups). To select this command, press the [CMD] key followed by the [SET PRICE] key. Then scroll to the secondary menu item of interest and press the [ENTER] key. The secondary menu items are as follows:

- Set Regular Prices

- Set Discount 1 Price
- Set Discount 2 Price
- Print Pricing Report

To execute one of the secondary commands, scroll through the secondary menu until the command of interest is displayed, and then press the [ENTER] key.

4.5.1 Set Regular or Discount Prices

Once a price level has been selected (regular, discount 1 or discount 2), the pricing of all features at that price level can be set. The label and current price of feature 1 will be displayed. At this point, you should type in the new price and press [ENTER], the price will be updated and the next feature label and current price will be displayed. Continue this for each feature. To keep the current price of a feature, simply press [ENTER] when the current price is displayed.

When entering discount prices, enter the final price to a customer. Do **NOT** enter the amount of the discount. If the discount prices are set to zero, they are considered free.

Each price must be entered as cents followed by the [ENTER] key. For example, a \$2.35 price would be entered as 235 followed by the [ENTER] key. To zero the price of an item, press the [0] key followed by the [ENTER] key.

Any time the prices are updated, a Current Pricing Report will automatically be printed. This report shows the current price of every feature at all 3 price levels. This report can also be generated by selecting the command "Print Pricing Report" from the secondary menu.

For POS4000 software versions 7.4 and later, the POS4000 will automatically update pricing at the WSII every time power is cycled to the WSII or communication is lost between the POS and the WSII for more than 20 seconds. This requires WSII version 3.10 or later.

 **Note:** Prices should only be set immediately after the counters are cleared and before any tickets are issued. This will avoid any confusion in the cash total.

Example to set regular (full) price structure:

```
[CMD]
[SET PRICES]
[2]                (password 2)
[ENTER]
[MENU UP/DOWN] until "Set Regular Prices" appears
[ENTER]
[3][5][0]          (set feature 1 full price to $3.50)
[ENTER]
[4][7][5]          (set feature 2 full price to $4.75)
[ENTER]
!                  (continue through all features)
!
[ENTER]
```

After the final feature price is programmed, a current pricing report will be generated.

**Note:**

When using Cash acceptance at the entry system, regular prices for Wash programs and Groups must be in ascending order. Thus Program 1 must be less than program 2, Program 2 must be less than program 3. If wash prices are not in ascending order then washes may be ignored, or falsely armed during a cash transaction at the entry system.

4.5.2 Print Pricing Report

This command is used to generate a report of the current prices of all features at all 3 price levels. Note that this report is automatically printed after any price level is set (see Section 4.5).

Example to print pricing report:

```
[CMD]
[SET PRICES]
[2]                (password 2)
[ENTER]
[MENU UP/DOWN] until "Print Pricing Report" appears
[ENTER]
```

4.5.3 Set Tax Rate

This command allows you to set the tax rate used when tickets are generated. To select this command, scroll through the system configuration secondary menu until "Set Tax Rate" is displayed and press the [ENTER] key. Once selected you will be prompted **Enter Tax Rate as 00.0%**. Type in the tax rate followed by the [ENTER] key.

Example to set Tax Rate to 5.0%:

```
[CMD]
[SET PRICES]
[2]                (password 2)
[MENU UP/DOWN] until "Set Tax Rate" appears
[ENTER]
[5][0]
[ENTER]
```

4.5.4 Enable TAX Round Off

This command allows you to enable or disable tax round off. The tax round off feature is useful when the price of a wash including taxes does not result in an even dollar amount. If tax round off is enabled then the amount of tax will be increased or decreased by \$0.01 to result in an even price. To select this command scroll through the system configuration secondary menu until "Enable TAX Round Off" appears, and then press [ENTER].

Once selected, you will be prompted to press [0] then [ENTER] to disable tax round off or [1] then [ENTER] to enable tax round off.

Example to enable tax round off:

```
[CMD]
[SET PRICES]
[2]                (password 2)
[MENU UP/DOWN] until "Enable TAX Round Off" appears
[ENTER]
[1]
[ENTER]
```

**Note:**

The default setup is tax round off disable. This feature is typically only useful when relatively large tax rates and/or prices are in use.

4.6 Service Routines

This command allows you to see the current system configuration and run various diagnostic tests. To select this command, press the [CMD] key followed by the [SERVICE] key. After entering the correct password, you can scroll through the secondary menu that follows:

- Print Configuration
- Link Test
- LED Test
- Print Last 10 customer transactions
- Set print to Display (non-printer mode)

To execute one of the secondary commands, scroll through the secondary menu until the command of interest is displayed, and then press the [ENTER] key.

**Note:**

Password 4 cannot be changed. It is always 62747. This is the only command that password 4 is used for. It is intended for use by service personnel during installation and while trouble-shooting problems.

4.6.1 System Configuration Report

The "Print Configuration" command is used to print detailed information about the setup and configuration of your POS4000 main console and customer interface. This report can be used to verify several user programmable parameters, (e.g. tax rate, languages, etc.) as well as fixed parameters (e.g. software version and system compatibility).

Example to print system configuration report:

```
[CMD]
[SERVICE]
[6][2][7][4][7] (password 4)
[MENU UP/DOWN] until "Print Configuration" is displayed
[ENTER]
```

**Note:**

If you need to contact technical support for assistance with your product, please have a current system configuration report available.

4.6.2 Link Test

The "Link Test" command is used to test the communication link between the main console and the customer interface. To execute this command, press [CMD][SERVICE], provide password 4, and then select "Link Test" from the secondary menu.

The console will prompt you to **Enter Unit Number or "0" to send to all**. The unit number refers to the specific component on the communication network to test. In a typical installation, the main

console is assigned unit #1 and the customer interface is assigned unit #2. You should type the unit number you wish to test followed by the [ENTER] key. The console will briefly display "Wait Response From" followed by "UNIT n RESPONSE OK" if the test was successful or "UNIT DID NOT RESPOND" if the test failed.

Example to test link with Unit 2:

```
[CMD]
[SERVICE]
[6][2][7][4][7]      (password 4)
[MENU UP/DOWN] until "Link Test" is displayed
[ENTER]
[2]
[ENTER]
```

4.6.3 LED Test

The "LED Test" command is used to test the Light Emitting Diodes (LED) located on the main console below the POWER LED. To execute this command, press [CMD][SERVICE], provide password 4, and then select "LED Test" from the secondary menu. At this point, you select from the following menu:

- Turn All LEDs Off
- Turn Wash-In-Use On
- Turn Out-Of-Serv. On
- Turn LED 3 On
- Turn LED 4 On
- Quit

The following procedure tests each LED:

```
[CMD]
[SERVICE]
[6][2][7][4][7]   Password 4
[ENTER]
[MENU UP/DOWN]    until "LED Test" appears
[ENTER]
[MENU UP]
[ENTER]           Wash-In-Use LED should turn on
[MENU UP]
[ENTER]           Wash-In-Use LED should turn Off, Out-Of-Service LED should turn on
[MENU UP]
[ENTER]           Out-Of-Service LED should turn off, LED 3 should turn on
[MENU UP]
[ENTER]           LED 3 should turn off, LED 4 should turn on
[MENU UP]
[ENTER]           LED 4 should turn off and the command is terminated
```

4.6.4 Set Print To display (Non printer Mode)

This command implemented in Version 6.67 allows the manual control of printing the customer's code to the display during a code printing. It is intended for when the ticket printer connected to the POS4000 is not functioning properly. When Set print to display is enabled, the customer code will be displayed on the POS4000 main screen for 10 seconds then cleared. The cashier must write this code down before it clears. While the code is displayed, no other code can be generated. The cashier must wait for the first customer code to clear before proceeding.

Example to set non-printer mode:

```
[CMD]
[SERVICE]
[6][2][7][4][7]          (password 4)
```

(Example to set non-printer mode cont.)

```
[MENU UP/DOWN] until "Set print to Display" is displayed
[ENTER]
```

```
[1] [ENTER]          to enable printing customer codes to display
```

4.6.5 Display POS Diags

This command is used in troubleshooting the connection to the external POS device. Enabling it will cause the POS4000 display to show diagnostic messages that may be useful to technicians or the Engineering division of Unitec. Do not use this command unless directed to do so by a qualified person.

Example to configure the displaying of POS diagnostic messages:

```
[CMD]
[SERVICE]
[6][2][7][4][7]          (password 4)
```

(Example to enable the setting)

```
[MENU UP/DOWN] until "Display POS Diags" is displayed
[ENTER]
```

```
[1] [ENTER]          to enable the displaying of POS diagnostics
```

4.7 Clear Audit Counts

This command prints an accounting report like the list counts command, but it also clears the selected counter level after the report is printed.

Three sets of the counters (shift, manager, and auditor) can be cleared. Each level requires a different password to clear. The shift, manager and auditor counts are cleared using passwords 1, 2, and 5 respectively.

Example to clear the Manager level:

```
[CMD]
[CLEAR REPORTS]
[MENU UP/DOWN] until "Clear Manager Counts" appears
[ENTER]
[2]          (password 2, depends on level requested)
```

[ENTER]

4.8 Set Messages

This command allows you to define the Header Message that is printed at the top of each ticket, the footer message that is printed at the bottom of each ticket and the Postscript messages that are optionally printed at the bottom of tickets.

To select the Set Messages command, press the [CMD] key followed by the [SET MSGS] key. The console will prompt you to enter password 1. Once the correct password is entered, you can scroll through the secondary menu that follows:

- Change Header Msg.
- Change Postscript 1
- Change Postscript 2
- Change Postscript 3
- Change Postscript 4
- Change Postscript 5
- Change Footer Msg.
- Change Coinbox Msg. (Esystem 4000 only)
- Print Message Config

To execute one of the secondary commands, scroll through the secondary menu until the command of interest is displayed, and then press the [ENTER] key.

4.8.1 Change Header Message

The Header Message is printed at the top of every ticket. It can be up to 10 lines long with each line containing up to 40 regular sized black or red characters (20 if bold characters are used). To change the Header message, scroll through the Set Messages secondary menu until "Change Header Msg" appears, then press the [ENTER] key.

Once the secondary menu item is selected, the console will prompt you to **Enter Line #, 99 All**. Individual message lines can be changed (enter the line number to change) or the entire message can be changed (enter 99). Type the line number to change (i.e.. 1, 2, 3...) or 99 to change the entire message, followed by the [ENTER] key.

Next, you will be prompted to enter the message for each line using the alternate key functions shown on the right side of the keys.

When the "change entire message" option is selected, the console will prompt for the text for the first line first. You should type in the text you want for line 1 followed by the [ENTER] key. Next, the console will prompt for the next line and so on until all lines are completed. All lines must be entered even if they are to be blank.

When you want a line to be blank, press only the [ENTER] key when the console prompts for the text for that line. Blank lines will be printed only if non-blank lines follow them. For example, if the last two lines of a message are blank they will not generate blank lines when printed.



Note: To simplify the message setup, it is recommended that the "change entire message" function be selected when several lines of a message are being changed. This will minimize the number of times the command has to be executed.

Example to change header message text:

```
[CMD]
[SET MESSAGES]
[1]                (password 1)
[ENTER]
```

(Example to change header message text cont.)

```
[MENU UP/DOWN] until "Change Header Msg." appears
[ENTER]
[9][9]            (to change all lines of message)
[ENTER]
[T][H][I][S][ ] [I][S][ ] [A][ ] [T][E][S][T]
[ENTER]
*
```

(repeat for each line)

```
*
```

4.8.2 Change Postscript 1-5

Up to 5 postscript messages can be defined. Each postscript message can be up to 5 lines long with each line containing up to 40 regular sized black or red characters (20 if bold characters are used). To change a Postscript message, scroll through the Set Messages secondary menu until the desired "Change Postscript #" message appears, then press the [ENTER] key.

Postscript messages are only printed when a ticket is issued with a wash function that has a postscript message number assigned to it. For example, if a ticket is issued with full price option 1 and postscript message 2 has been assigned to the full price option 1 feature, postscript message 2 will be printed at the end of the ticket.

The current assignment of postscript messages is included on the Message Configuration Report. If a ticket contains more than 1 feature with the same postscript message assigned to it, the postscript message will only be printed once. If a ticket contains more than 1 feature with different postscript messages assigned to them, they will be printed in ascending order (1 - 5) regardless of the order of the wash functions they are associated with. If a ticket contains postscript messages and a footer message, the postscript messages will be printed first.

The process for changing a Postscript message is identical to that used to change the Header message.

Example to change Postscript message 1:

```
[CMD]
[SET MESSAGES]
[1]                (password 1)
[ENTER]
[MENU UP/DOWN] until "Change Postscript 1" appears
[ENTER]
[9][9]            (to change all lines of message)
[ENTER]
[T][H][I][S][ ] [I][S][ ] [A][ ] [T][E][S][T]
[ENTER]
*
```

(repeat for each line)

*
[ENTER]

4.8.3 Change Footer Message

The Footer Message is printed at the bottom of every ticket. It can be up to 10 lines long with each line containing up to 40 regular sized black or red characters (20 if bold characters are used). To change the Footer message, scroll through the Set Messages secondary menu until "Change Footer Msg" appears, then press the [ENTER] key.

The process for changing the Footer message is identical to that used to change the Header message.

Example to change footer message:

```
[CMD]
[SET MESSAGES]
[1] (password 1)
[ENTER]
[MENU UP/DOWN] until "Change Footer Msg." appears
[ENTER]
```

(Example to change footer message cont.)

```
[9][9] (to change all lines of message)
[ENTER]
[T][H][I][S] [I][S] [A] [T][E][S][T]
[ENTER]
* (repeat for each line)
*
[ENTER]
```

4.8.4 Change Coinbox Messages (E-System 4000 Only)

The entry system messages define the text contained on the LCD displays on the E-System 4000 entry system. The first line will contain the wash name and price. The second line may be edited to your choosing. If you edit the first line, it will be re-written to the wash name and price if you change either.

The process for changing the entry system message is different from the other messages. You will be prompted for the display number (Note displays are numbered from bottom to top, corresponding to Program 1 - 4 or Groups 1 -4). You will also be prompted for the line number (1 is the top and 2 is the bottom).

Example to change Display 1 Line 2 (top display bottom line) message:

```
[CMD]
[SET MESSAGES]
[1] (password 1)
[ENTER]
[MENU UP/DOWN] until "Change Coinbox Msg" appears
[ENTER]
[1] (to change display number 1)
[ENTER]
[2] (to change line 2)
[ENTER]
[W][A][S][H] [I][D] [R][Y] [ ] [ ] [W][A][X]
[ENTER]
```

After updating the messages, the current message structure will be updated onto the entry system message screens.

4.8.5 Print Current Message Configuration

This command is used to generate a printout of the current header message, postscript messages and their assignments and footer message. To execute this command, scroll through the Set Messages secondary menu until "Print Message Config" appears and then press [ENTER].

Example to print current message configuration report:

```
[CMD]
[SET MESSAGES]
[1] (password 1)
[ENTER]
[MENU UP/DOWN] until "Print Message Config" appears
[ENTER]
```

4.9 Set Passwords

This command allows you to change the passwords that control access to specific commands. To select this command press the [CMD] key followed by the [PASSWORDS] key. You will be prompted to enter password 3. Once the correct password is entered, you can scroll through the secondary menu that follows:

- Change Password 1
- Change Password 2
- Change Password 3
- Change Password 5
- Change Serial Pass (password used for access via serial port)

To execute one of the secondary commands, scroll through the secondary menu until the command of interest is displayed, and then press the [ENTER] key.



Note:

Password 4 cannot be changed. It is intended to be used by service personnel. Password 4 only allows access to the Service Routines command.

4.9.1 Change a Specific Password

To change a password, scroll through the secondary menu until the password of interest is displayed, and press the [ENTER] key. At that point, you will be prompted to enter a new password. Enter a numeric password between 0 and 4,294,967,295 and then press the [ENTER] key. The new password will be printed as a confirmation. Save and protect access to this password.

Example to change password 1 to 12345:

```
[CMD]
[PASS WORDS]
[3] (Password 3)
[ENTER]
[MENU UP/DOWN] until "Change Password 1" appears
```

[ENTER]
[1][2][3][4][5] (new password 1)
[ENTER] At this point the new password will be printed.



Caution: SAVE THIS LISTING. THERE IS NO METHOD TO DETERMINE THE CURRENT PASSWORDS ONCE THEY HAVE BEEN CHANGED.

If password 3 is forgotten, a service call will be required to reset the system. This reset will return EVERYTHING to factory default values and will delete all codes from memory.

The System Configuration report (see Section 4.1) contains a section that contains the DEFAULT passwords for the system (not the current passwords if they have been changed).

The use of larger passwords maximizes the security of the system. However, if you are not concerned about system security a shorter password can be used. For example, if you changed password 1 to be 1, you would only be required to enter 1 when password 1 was requested.

4.10 Void a Code

This command is used to delete a single valid code from memory. Carwash codes can only be voided prior to use. Once a code has been voided, it will not activate the carwash. To select the void code command, press the [CMD] key followed by the [VOID CODE] key. The console will prompt for password 1, followed by the code number to be voided.

If the code is valid, several things will occur:

- The code is removed from the valid code memory.
- A void code ticket is printed. The cashier should sign this ticket and save it with the original ticket for use in the shift close-out audit.
- The cash value of the ticket is added to the void ticket account (this account is included in the audit report).

If the code is not valid, a message will be printed indicating this.

Example to void code 123450:

```
[CMD]
[VOID CODE]
[1] (password 1)
[ENTER]
[1][2][3][4][5]
[ENTER]
```

4.11 Memory Information

The memory management command provides you with a means to review and control the customer code memory of the POS4000. To select this command, press the [CMD] key followed by the [MEMORY] key. The console will prompt for password 2. Once the correct password is entered, you can scroll through the secondary menu that follows:

- Print Valid Codes
- Print Used Codes
- Clear ALL Valid

- Clear ALL Used
- Clear Old Codes

To execute one of the secondary commands, scroll through the secondary menu until the command of interest is displayed, and then press the [ENTER] key.



Note: This command does not give access to the fleet account information.

4.11.1 Print Valid Codes

This command can be used to print all valid codes. To execute this command, scroll through the MEMORY secondary menu until "Print Valid Codes" appears. Then press [ENTER].

When this command is executed, the console will display the total number of valid codes in memory and then prompt for the number of codes that you want printed. Type the number of codes you want followed by the [ENTER] key. The console will print that many of the most recently issued valid codes.

Example to print 50 most recent valid codes:

```
[CMD]
[MEMORY]
[1]                (password 1)
[ENTER]
[MENU UP/DOWN] until "Print Valid Codes" appears
[ENTER]
[5][0]            (number of codes you want printed)
[ENTER]
```

4.11.2 Print Used Codes

This command is the same as the "Print Valid Codes" command except that it prints the most recently used codes.

4.11.3 Clear ALL Valid Codes

This command cancels all valid customer codes currently in memory. To execute this command, scroll through the MEMORY secondary menu until "Clear ALL Valid" appears. Then press [ENTER].

In addition to the password security, this function requires you to confirm the operation by entering 99. This provides extra security to avoid accidental deletion of the codes. This command does not delete fleet account codes.

Example to delete all valid codes from memory:

```
[CMD]
[MEMORY]
[1]                (password 1)
[ENTER]
[MENU UP/DOWN] until "Clear All Valid" is displayed
[ENTER]
[9][9]            (enter 99 to proceed)
```

[ENTER]

4.11.4 Clear ALL Used Codes

This command is the same as the Clear ALL Valid command except that the used customer codes are canceled.

4.11.5 Clear Old Codes

This command allows you to cancel valid customer codes that were issued prior to a specific date. This command is required to enforce the code age warning (see Section 4.1.3) printed at the bottom of a ticket. To select this command, scroll through the secondary menu until "Clear Old Codes" is displayed. Then press [ENTER].

Once you have selected this option, you will be prompted for the date to delete codes prior to in the format MMDDYY (month, day and year each as 2 digits). All codes issued prior to this date will be deleted. For example: if you enter 050692, all valid codes issued prior to May 6, 1992 will be marked for deletion. Note 00-89 = 2000-2089 and 90-99 = 1990-1999.

The console will then prompt you to either cancel only the "0=Free" codes (total price was "\$0.00") or the "1=All" codes. Press [0] then [ENTER] to delete only free codes or [1] then [ENTER] to delete all codes. Once you have made this selection, the console will print a report indicating the number of valid codes currently in memory and the number of codes that will be deleted by your current request. At this point, you must press [9][9][ENTER] to confirm that you wish to cancel the codes selected. If you enter any other number or just press [ENTER], the command will be aborted and no codes will be deleted.

Depending upon the number of codes being deleted, this command may require several minutes to complete. This is normal. During this time, other functions cannot be performed. Codes deleted will NOT be found using the check code command.



Warning:

If the console time has been changed recently by one or more days, unanticipated code cancellations could occur. This command uses the current date (as set in the POS4000) and the date codes were issued (also as set in the POS4000) to determine which codes will be canceled.

4.12 Code Sales Lockout

This menu of commands allows the POS4000 to lock out code sales at the console. This is available if you want to disable the ability to sell codes from the console only. This can be used for instance when the POS4000 is connected to an External POS device (Site controller or Register) and it is desired to keep from issuing sales from the console. Two functions are available:

- **Lock Console Sales** – Enables or Disables console sales
- **Change Password** – Changes the Code lockout password



Note: This menu is password protected by the “Code Lockout Password”. This password is defaulted to 272001.

4.12.1 Lock Console Sales

This function is used to enable or disable the Console code sales. When enabled, no codes can be printed from the console. No external POS functions will be affected by this feature. Check a code and Void a code functions are also not affected by this feature.

Example to enable console code sales lockout feature:

```
[Menu Down]      until you see “Code Sales Lockout”
[Enter]
[272001]          (Lockout password )
[ENTER]
Screen should show “Lock Console Sales”
[ENTER]
[1]              1 to Enable (0 to disable)
[ENTER]
```

4.12.2 Change Lockout Password

This function is used to change the Console Code Lockout password.

Example to Change Lockout Password:

```
[Menu Down]      until you see “Code Sales Lockout”
[Enter]
[272001]          (Default Lockout password)
[ENTER]
Screen should show “Lock Console Sales”
[Menu Up]
Screen should show “Change Password”
[ENTER]
[XXXXX]          Enter new password (up to 8 digits)
[ENTER]
```

4.13 Check Code Status

This command allows you to check the status of a code. To access this command, press the [CMD] key followed by the [CHECK CODE] key. The console will prompt you to enter the code to check. Type the code to check followed by the [ENTER] key. The console will print the status of the code as either valid, used, previously canceled or not in memory.

If the code is valid, the date/time it was issued and the features associated with are printed. If the code has been used, the date/time it was redeemed is printed. If the code was previously canceled (using the void code command), the date/time that it was canceled is printed. If the code is not found in memory, the date and time of the oldest valid and used codes currently held in memory will be printed.



Note: Fleet account codes will not be validated by this function for the security of those accounts.

Possible conditions if code not found:

- Issue date on ticket older than the oldest valid code: Ticket may or may not have been used (Can not determine). If ticket is older than code age warning on ticket, note this to the customer.
- Issue date on ticket younger than oldest valid code but older than oldest used code:
- Ticket was used, but has since rolled out of the used codes database.

Example to check code 123450:

```
[CMD]
[CHECK CODE]
[1][2][3][4][5]      (0 is optional)
[ENTER]
```

4.14 Setup a Feature

This command allows you to change the label (or name) of the features associated with each of the cashier keys. These names are printed on tickets when codes are generated, accounting reports, pricing reports and the system configuration report.

This command is also used to assign a postscript message to a feature at a specific price level. For example, option 1 could be programmed to print a different postscript message when issued at full price than when issued at discount 1 or discount 2. This allows you to have special messages with certain discount levels.

To select the setup command, press the [CMD] key followed by the cashier key you want to setup. Once the correct password is entered, you can scroll through the secondary menu that follows:

- Change Wash Name
- Set Reg. Postscript
- Set Dis 1 Postscript
- Set Dis 1 Postscript
- Set Postscript All \$

To execute one of the secondary commands, scroll through the secondary menu until the command of interest is displayed, and then press the [ENTER] key.

4.14.1 Change Feature Name

To change the name (or label) of a feature, scroll through the Setup secondary menu until "Change Wash Name" is displayed. Then press the [ENTER] key.

At this point, the top line of the display will prompt you to **Enter Label Name** and the second line will display the current name of the feature. By using the alphanumeric characters on the keys, you should type in the new name of the feature.



Warning:

If you press [ENTER] when the current name is displayed, you will change the label to be BLANK.

Example to change the name of feature 1 (typically "PROGRAM 1") to "ECONO-WASH":

```
[CMD]
[FEATURE 1]                (cashier key)
[1]                        (password 1)
[MENU UP/DOWN] until "Change Wash Name" appears
[ENTER]
[E][C][O][N][O][ ][-][W][A][S][H]    (to type [-] you must press [SHIFT] then [R] then
                                        [SHIFT] again to return to the lower characters)
[ENTER]
```



Note: The [BOLD], [CENTER] and [RED] keys have no effect on wash names.

4.14.2 Assign a Postscript Message to a Feature

The following secondary menu commands allow you to assign a postscript message to a specific price level or to all price levels of a feature:

- Set Reg. Postscript (Assign to Regular price only)
- Set Dis 1 Postscript (Assign to Discount 1 only)
- Set Dis 2 Postscript (Assign to Discount 2 only)
- Set Postscript All \$ (Assign to all price levels)

Here are some examples of why you might want to assign different postscript messages to different price levels. If you give a free wash with a gas fill up, you could print a special message indicating that this wash is free only with a fill up. Full priced washes could have a postscript message that indicates that the receipt can be used as a coupon for a discount on other merchandise or on a higher priced wash. Full priced washes could have a postscript message that indicates that a discount is available if gas, merchandise or other services are purchased.

If a ticket contains more than 1 feature with the same postscript message assigned to it, the postscript message will only be printed once. If a ticket contains more than 1 feature with different postscript messages assigned to them, they will be printed in ascending order (1-5) regardless of the order the wash functions were selected.

Before assigning postscript message numbers to particular wash functions, it is recommended that you define the postscript message text first (see Sections 4.8.2). Then print a System Configuration report (see Section 4.1). Having a listing of the postscript message text when you assign postscript message numbers to the wash functions can reduce selection errors.

Example to assign postscript message 3 to Opt 2 at all price levels:

```
[CMD]
[Opt 2]                    (cashier key)
[1]                        (password 1)
[ENTER]
[MENU UP/DOWN] until "Set Postscript All $" is displayed
[ENTER]
[3]                        (select postscript message 3)
[ENTER]
```

5 Cashier Operations

The "cashier" keys are the 12 keys (usually yellow) on the bottom half of the keyboard. The main console has been designed so that the majority of cashier operations will be performed using the cashier keys. Each cashier key corresponds to a single feature. A feature may be a wash program, option or group. The number of each type of feature present and their location on the keypad depends upon the software installed in the POS4000 and cannot be changed by the user.



Note: During cashier operations, the text on the right hand side of the keys is not used.

5.1 Issuing A Customer Ticket

The cashier keys allow you to select various types of wash programs, options or groups. Any of these wash programs, options or groups can be provided at full, discount 1, or discount 2 prices. The number of programs and options available is dependent on the specific carwash equipment.

To issue one full price customer code, simply press the wash program key and desired option keys followed by the [ENTER] key.

As cashier keys are pressed, the cumulative price of the features will appear on the top right of the display, an abbreviation of the features will appear on the top left of the display. The wash programs are identified on the display as P1, P2 ..., the options are identified on the display as O1, O2..., and groups are identified as G1, G2 ...

An item is discounted by pressing the Discount 1 or Discount 2 key **before** pressing the key of the feature to be discounted. The selection is finalized by pressing the [ENTER] key. At this point, the customer's receipt will be printed with:

Header message

Customer selections and cost of each item

Discount amounts (in red)

Current day and time

Customer instructions

Unique customer access code

Code age warning

Specific postscript customer messages

Footer Message

Discounted features will be printed as a full price item first followed by the amount of discount in red to emphasize to the customer that a discount has been given.

In the event of an erroneous selection, the current features can be canceled by pressing the [CLEAR] key. If an attempt is made to print a ticket for which no wash program and no group selection were made (options only), an invalid wash selection message will be displayed. If a particular feature has been selected with different discounts, the last selection will be honored.

Example: Full price P1 & O1

[Prog 1]
[Opt 1]
[ENTER]

Example: Full price-P2 & discount 1-O1

[Prog 2]
[DISC 1][Opt 1]
[ENTER]

Example: Discount 2-P2 & discount 2-O1 & discount 2-O2

[DISC 2][Prog 2]
[DISC 2][Opt 1]
[DISC 2][opt 2]
[ENTER]

5.2 Issuing Multiple Customer Tickets

Multiple identical carwash tickets (each with a unique access code) can be generated using a limited number of keypad entries. To generate these tickets, simply enter the number of tickets (10 or less) to be printed using the numbers on the management keys (upper keys on keypad), and then continue to issue the carwash ticket desired. When the carwash ticket is issued, multiple tickets will be printed. For example, to get 5 customer tickets with identical feature selections, first depress the 5 key on the management keypad (do not press the enter key at this time). Then proceed through the normal carwash ticket generation procedure.

Example: Print 5 full price P1 & O1 tickets

[5] (Number of tickets to print)
[Prog 1] (Features of each ticket)
[Opt 1]
[ENTER]

5.3 Issuing A Rain check Receipt

Rain checks can be printed by simply pressing the rain check key. The rain check ticket will include the header message, date and time of issue. These tickets must be traded for a carwash code at a later time.

Example:

[Rain Check]

Rain checks should be given to a customer when it is anticipated that the carwash will not be operating for an extended period. If codes are used as rain checks for an extended period, these codes may eventually be deleted from the valid codes memory to make room for new codes.

5.4 Checking a Customer Code

The status of a customer code can be verified with the [CHECK CODE] command. To access this command, press the [CMD] key followed by the [CHECK CODE] key. The console will prompt you to enter the code to be checked. Type the code to check followed by the [ENTER] key. The console will print the status of the code as either valid, used, previously canceled or not in memory.

If the code is valid, the date/time it was issued and the features associated with it are printed. If the code has been used, the date/time it was redeemed is printed. If the code was previously canceled (using the void code command), the date/time that it was canceled is printed. If the code is not found in memory, the date and time of the oldest valid and used codes currently held in memory will be printed.

Note that fleet account codes will not be validated by this function for the security of those accounts.

Note that with a multiple-console configuration that codes can be checked at either the master console or the console the code was generated from (console connected to the Extpos).

Possible conditions if code not found:

- Issue date on ticket older than oldest valid code: Ticket may or may not have been used (can not determine). If ticket is older than code age warning on ticket, note that to the customer.
- Issue date on ticket younger than oldest valid code but older than oldest used code:
- Ticket was used but has since rolled out of the used code database

Example to check code 123450:

```
[CMD]
[CHECK CODE]
[1][2][3][4][5]      (0 is optional)
[ENTER]
```

5.5 Voiding a Customer Code

Carwash codes can be voided prior to use. Once a code has been voided, it will not activate the carwash. To void a code, press the [CMD] key followed by the [VOID CODE] key. The console will prompt for password 1, followed by the code number to be voided. If the code is valid, several things will occur:

- The code is removed from the valid code memory.
- A void code ticket will be printed. The cashier should sign this ticket and save it with the original ticket for use in the shift closeout audit.
- The number of codes voided is listed on the Accounting Report in the Codes Void section.
- The dollar value of the ticket will be added to the void ticket account (this account is printed in the audit report as Sales Refunds in the Register Summary section).

If the code is not valid, a message will be printed indicating this.



Note:

In a multiple-console configuration, codes can be voided at either the master console or at the console the code was generated from (console connected to the Extpos).

Example to void code 123450:

```
[CMD]
[VOID CODE]      (Unit prompts for password 1)
```

[1] (password 1)
[ENTER]
[1][2][3][4][5]
[ENTER]

6 Customer Access

A customer receives a car wash by entering his unique access code at the customer interface located at the entrance of the car wash. The customer interface includes a metal numeric keypad, coin and bill acceptor interfaces (coin/bill activation and change making is optional) and customer display.

To receive a wash, the customer enters his unique car wash code on the numeric keypad. The "0" that is the last character of every code is used as an enter key. When the code is completely entered and it is determined that the code is not an account number, that code is shown on the main console display in the lower right corner. If the code is valid, the wash type is simultaneously issued and shown on the lower line of the main console display. The issued wash types are identified on the display as P1, P2..., G1, G2... and O1, O2... for program 1, program 2 ..., group 1, group 2 ..., option 1, option 2 ... respectively.

If the code is invalid, a buzzer will sound at the main console and at the customer interface. The number of invalid codes (since the last valid code) will be shown on the lower line of the main console display. The number of sequential invalid codes can be used to alert the cashier of tampering at the entrance console. Additionally, the "re-enter code" relay will be turned on briefly to control a customer guidance light.

If the car wash is in-use when a valid code is entered, a "Code Accepted/Please Wait" relay is activated at the interface. This relay remains on until the wash is available.

6.1 Cash Upgrades (Buy ups) at the Carwash Entrance

**Important:**

POS4000 features that are not available on your particular carwash equipment should be disabled in order for the entry system upgrades to be sold correctly.

As an optional feature, the POS4000 can be configured to allow customers to purchase a wash or upgrade from a valid code by depositing cash at the entrance of the wash. This capability requires a quarter acceptor and/or a bill acceptor be installed at the customer interface and requires the buy up mode to be enabled. The current buy up mode is included in the System Configuration Report.

**Note:**

Buy up mode is not configurable for Hamilton Autotec systems.

If a customer deposits more money than is required, the extra money is escrowed for additional purchases by that customer until they enter the wash. If escrowed money remains when the customer enters the wash, an overpayment statement is printed at the main console. This statement includes:

- Customer code or cash only notice
- Current date and time
- Features selected and cost

- Amount deposited
- Amount overpaid (in red)

If the customer returns to recover his overpayment, the cashier should have the customer sign the overpayment ticket and save it along with the customer's original wash ticket with their code for accountability.



Note:

When configuring cash acceptance (buy ups), wash programs and groups must be in ascending order (i.e. Program 1 must cost less than Program 2.) Failure to do so will result in improper cash handling at the customer interface.

6.1.1 BUYUP: Automatic By Price

This buy up mode allows customers to either upgrade the value of a valid code or purchase a wash with cash deposited at the customer interface. To make a total cash selection (no code), the customer simply deposits cash equal to the "full" price of the wash desired.

To upgrade a wash after entering a code, the customer simply deposits the difference between the full price of the wash desired and the full price of the wash activated by the code. Note that the full price of the code-activated program is used even if the code was purchased at a discount. As an example, assume the following price structure:

<u>WASH TYPE</u>	<u>FULL PRICE</u>
Program 1	\$2.50
Program 2	\$3.50
Program 3	\$4.00
Program 4	\$4.50
Option 1	\$1.00
Option 2	\$1.00
Option 3	\$0.75

Assume that a customer purchases a program 2 wash (either full priced or at a discount) from the cashier and receives a ticket with a valid code. The customer then drives to the carwash entrance and enters that code. At this point, the customer can enter the wash to receive program 2 or deposit \$1.00 to upgrade to program 3 or deposit \$1.50 to receive program 4. The amount of cash required to upgrade is the same regardless of the price level of the original code.

Once the highest priced program has been purchased, the customer can continue to upgrade by adding options (if options are present on your system). Continuing the previous example, assume the customer has upgraded to program 4. At this point, the customer can add option 1 by depositing \$1.00, options 1 & 2 by depositing \$2.00 or options 1 & 2 & 3 by depositing \$2.75.

Upgrading from one program to the next is done by depositing the difference in the full price of the programs (since one program is replaced with the other). Upgrading from one option to the next is done by depositing the full price of the next option (since each option is added to the current wash program).

If a customer purchases a program type ticket (as opposed to a group type ticket) from the cashier or makes an all cash purchase at the wash entrance, the buy up sequence will proceed through all program type washes and then add all options as follow:

Prog 1, Prog 2, ... Prog N, Opt 1, Opt 2, ... Opt N.



Note: Options that were included in the original code are not included in the buy up process.

If the customer purchases a group type ticket from the cashier, the buy up sequence will proceed through all group type washes as follows:

Group 1, Group 2, ... Group N.

If the price of a wash program is less than the price of a lower numbered program, it will not be included in the buy up process. For example, assume the following price structure:

Program 1	\$3.00
Program 2	\$2.00
Program 3	\$4.00

A cash only customer would have to deposit \$3.00 to purchase program 1, and then add another \$1.00 to purchase program 4. A customer with a code valid for program 1 would also have to deposit \$1.00 to upgrade to program 3. Program 2 would not be available to either of these customers.

A customer with a code valid for program 2 would have to deposit \$2.00 to upgrade to program 3, program 1 would not be available to this customer.

Any program, option, or group cashier keys that are disabled (see Section 4.1.5) will be skipped in the buy up sequence. For example, if the console has four program keys (program 1 to program 4) and four option keys, but program 4 is disabled, then a customer with a program 2 ticket could upgrade as follows:

Program 3, Option 1, Option 2, ... Option 4.

Note that program 4 is not available in this buy up example.



Note: By using entry systems that provide change-making capabilities, customers may deposit more money than that required for the wash they wish to purchase. The customer will be prompted to select their desired wash and change will be dispensed.

6.1.2 BUYUP: Audit-Selected-Options

This type of buy up may not be available with your equipment. If this item does not appear on the display while executing the SYSTEM SETUP - Set Buy up Mode command then it is NOT available with your system.

This feature allows a customer to select and purchase any combination of options at the entrance of the wash. To purchase a base wash or add options to a valid code, the customer selects the desired options and then must deposit cash to pay for the selected options. Appropriate messages are displayed to help guide the customer through the process.

6.1.3 Buy up: Forced Selection (Available for E-systems 4000 only)

This type of buy up is available for E-systems 4000 units with change making only. Forced selection will function similarly to Auto by price, except in an "all cash" transaction (customer does not enter a code). The customer will be required to make a wash selection before any wash is armed. The customer may make the wash selection before or after the cash is entered.

In a transaction where the customer enters a code, the wash will arm the same as in Auto by Price. No selection will be required unless the customer tries to buy up with \$5 or more.

6.2 Customer Stacking



Important: This feature is not supported by all configurations.

If Customer Stacking is supported it will appear on your system configuration report as "Customer Stacking: Enabled"

If Customer Stacking is not supported it may appear on your system configuration report as "Wash in use Lockout: Enabled"

Customer stacking allows a second customer to be processed at the entrance of the carwash while the previous customer is in the carwash. Permitting customers to enter their code and/or cash while waiting for the customer ahead of them increases the throughput of the wash.

Once the second customer enters a valid code (or deposits enough cash to purchase a wash), the "Code Accepted/Wait" relay will close until the wash in-use signal turns off. When the wash in-use signal turns off, the "Code Accepted/Wait" relay will open and the "Enter Wash" relay will close until the wash in-use signal turns on again (indicating that the second customer has entered the wash).

All systems allow a second customer to be processed while the previous customer is in the carwash. The relay stacking section of the SYSTEM CONFIGURATION indicates if the function relays will be closed as soon as a valid code is entered (relay stacking disabled) or if the function relays will wait until wash in-use turns off (relay stacking enabled).

7 Printer Instructions

The following section provides information on the printers that come with the POS4000. There are two different models, but both are made by Citizen. If additional information is needed, consult the complete manual that came with the printer.

7.1 Instructions for Citizen Model CD-3535

7.1.1 General Cautions

1. Never operate your printer without loading the paper and ribbon cassettes. Any printing without these cassettes loaded may cause damage to the printer head.
2. Replace the ribbon cassette before it is worn out with rents.
3. Be careful not to drop any foreign objects, such as paper clips, pins and the like not your printer. This can cause mechanical trouble.
4. Nothing should be placed on the radiation vents of the printer.
5. Place the printer on a stable desk, which is set horizontal.
6. Do not use any organic solvent (thinner benzene, etc.) to clean the body of the main case.
7. Make sure the power of the printer is turned off whenever you do the following:
 - Taking out any foreign matter, which was dropped into the printer.
 - Replacing the ribbon cassette.

7.1.2 Setting and Removing the Printer Cover

The figure below illustrates setting and removing the printer cover.

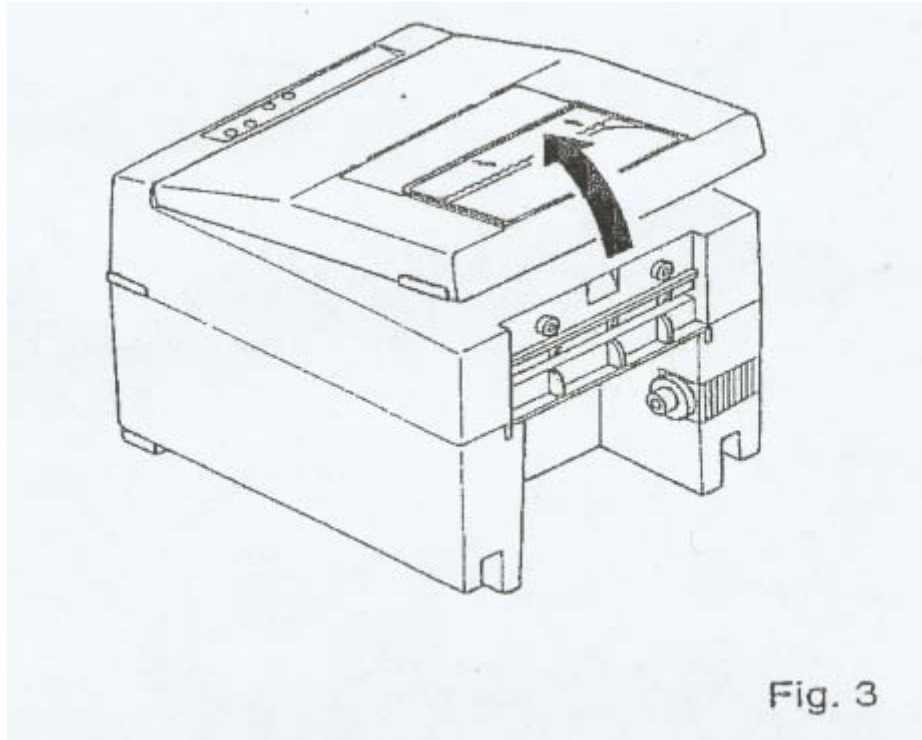

Figure 5. Setting and Removing the Printer Cover

7.1.3 Ribbon and Cassette Installation

In order to set the ribbon, disconnect the power source before hand. When the printing has been continued for many hours, be careful not to touch the printer head, as it might be hot.

1. Remove the printer cover.
2. While inserting the ribbon into the space between the print head and the ribbon guide, press the cassette into the holder until, it clicks into place. (Refer to fig. 4 & 5)
3. Turn the cassette ribbon knob in the direction of the arrow to take up slack in the ribbon.

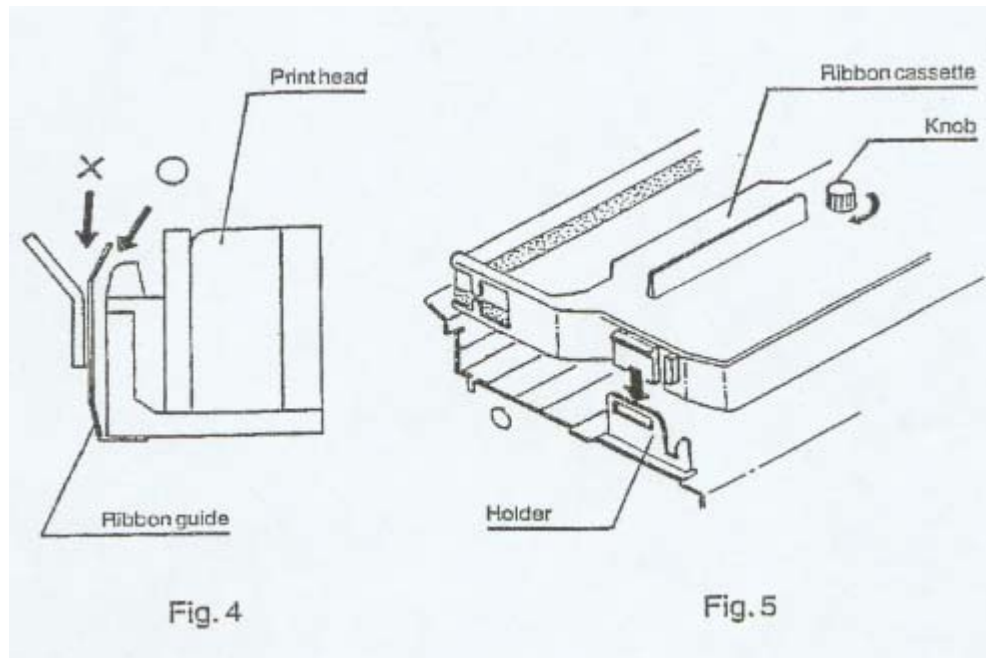

Figure 6. Installing the Printer Ribbon and Cassette

7.1.4 Loading and Changing the Paper

Using Paper Roll:

1. Cut the paper at a right angle to its longitudinal centerline as shown in fig. 7.
2. Insert the paper into insertion inlet on the rear side of the printer.
3. Turn on the power switch and feed the paper by pushing the LF switch.
4. When the paper comes out of the clearance (paper cutter part) on the printer cover, fix the paper by means of paper holder, then set in on the main unit.

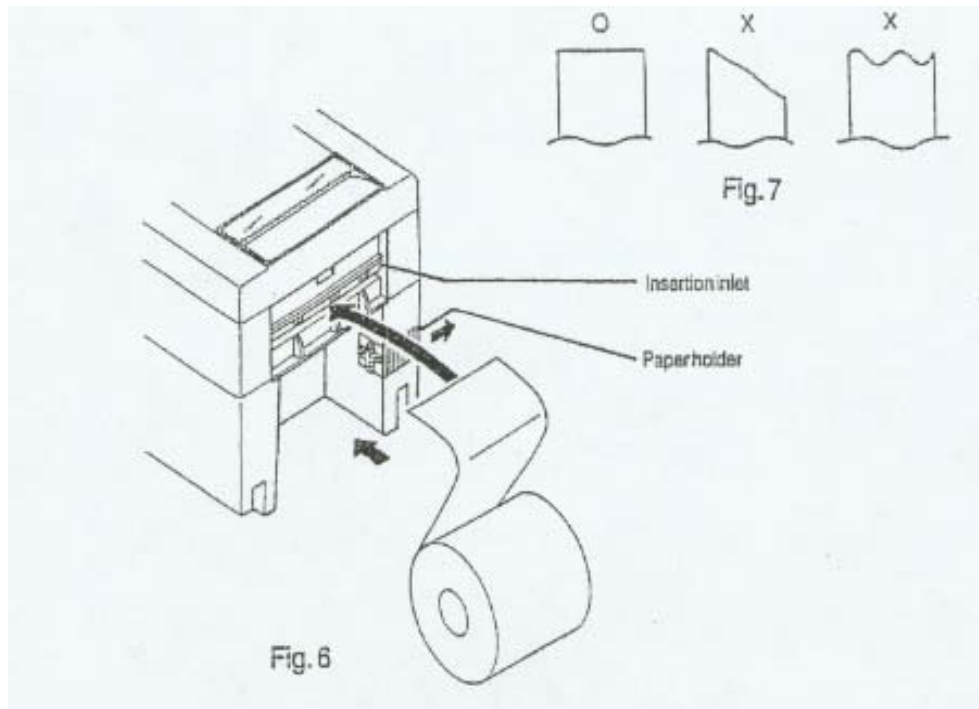

Figure 7. Loading the Printer Paper

7.1.5 Actuating the Print Functions

1. Be sure that a paper role is properly loaded.
2. Confirm that the ribbon cassette is properly installed and turn the power switch off.
3. Turn the power switch on while pressing the LF switch, and then release the LF switch after the self-test has begun.

In the above operation, the self-print function will stop automatically when completed. However, the self-print function will not operate without paper.

7.1.6 Alarm and Paper Near-End Detection

This printer has the paper near-end sensor to stop the operation when the paper comes to near-end, sending out both BUSY and FAULT signals. This status is indicated by the SEL/ALARM lamp blinking at an interval of one second.

If the printer goes alarm, the printer stops printing out and outputs FAULT signal OFF-LINE state. This status makes the SEL/ALARM lamp blink at an interval of one quarter of a second.

7.1.7 DIP Switch Settings

The following table lists the DIP Switch settings for Citizens Printers Models 3530 and 3535.

Table 16. Printer DIP Switch Settings

DIP Switch	ON	OFF
1	X	
2		X
3		X
4		X
5		X
6		X
7		X
8		X

7.2 Instructions for Citizen Model CD-S500

Refer to the Citizen CD-S500 operations manual, page 36 for more information on configuring the printer.

Table 17. Citizen CDS500 Printer Settings

Configuration Settings	
Command Type	CBM2
Number of Col.	42/35
Font Select	7*9

To configure the printer for operation with the POS4000, perform the following procedure:

1. With the front cover open, turn power on while pressing the FEED button; then release the FEED button.
2. The POWER LED will flash as the printer enters the maintenance mode; close the front cover.
3. Press the FEED button until you hear a single beep; reopen and close the front cover.
4. Press the FEED button until you hear a single beep and release it. The printer will print the setting for COMMAND TYPE. Continue to press the FEED button until the printer prints "Command Type -CBM2".
5. Press and hold the FEED button until you hear a single beep followed by three quick beeps.

6. Press the FEED button until you hear a single beep and release it. The printer will print the setting for NUMBER OF COL. Continue to press the button until the printer prints "Number of Col. -42/35".
7. Press and hold the FEED button until you hear a single beep followed by three quick beeps.
8. Press the FEED button until you hear a single beep and release it. The printer will print the setting for FONT SELECT. Continue to press the button until the printer prints "Font Select -7*9".
9. To save the configuration, open and close the front cover.

8 Backup Operations

The POS4000 interface board has a backup mode of operation that provides the ability to use up to 5 different customer codes that provide repeated access to up to 4 different wash types. Backup mode should be used in the event that a POS4000 main console failure prevents use of the normal codes generated and stored by the main console.

To activate backup mode, DIP switch 4 should be moved to the ON position.

There are 3 passwords that provide access to the programming features of the backup mode. While the interface board is in backup mode, typing one of the passwords at the customer keypad will cause the interface board to enter a programming mode and then wait for the appropriate data to be typed at the customer keypad.

Table 18. Password Types

Password Type	Value	Description
Change-Password	15627470 (Fixed)	Used to change the Change-Codes password
Change-Codes	23123450 (Changeable)	Used to change the 5 backup customer codes
Change-Relays	43539210 (Fixed)	Used to change the relays related to each customer code

After one of the three passwords is entered, the unit has a programming time limit of roughly 1 minute. If no keys are pressed for more than 1 minute, the unit will return to backup mode of operation. If this happens, you must start programming over. This time limit prevents you from accidentally leaving the unit in the programming mode of operation.



Note:

Only the change-codes password can be changed. For this reason, it is recommended that the manager only give operators the change-codes password.

8.1 Programming the Change-Codes Password

The default value for the change-codes password is 23123450. If you want to change this password, you do so by entering the change-password password, which is 15627470. After the change-password password has been entered, the interface board will wait for a new change-codes password to be entered. The change-codes password must end in a 0 may not contain a 0 anywhere else in the password and must be 8 or fewer digits long (including the 0).

Example to make the change-codes password 76543210:

[1][5][6][2][7][4][7][0] (Change-password password)

[7][6][5][4][3][2][1][0] (New change-codes password)

8.2 Programming Backup Customer Codes

The default backup customer codes are 10, 20, 30, 40 and 50. These codes can easily be changed by entering the change-codes password. After the change-codes password has been entered, the interface board will beep once and wait for the first customer code to be entered. After a code is entered, the interface board will beep a number of times to indicate which customer code should be entered next (2 beeps indicates that the second code should be entered, 3 beeps indicate the third code should be entered, etc.). If the optional customer display is connected, messages are displayed to guide you through the 5 codes.

Example to make backup customer codes 110,220,330,440 and 550:

[2][3][1][2][3][4][5][0] (Default change-codes password)

[1][1][0] (Backup customer code # 1)

[2][2][0] (Backup customer code # 2)

[3][3][0] (Backup customer code # 3)

[4][4][0] (Backup customer code # 4)

[5][5][0] (Backup customer code # 5)

Uses of the backup customer codes are recorded by the interface card. When the POS4000 console is operational again and the interface card is placed back in the normal POS4000 mode of operation, backup code usage is reported to the console and included in the audit reports.

8.3 Programming the Output Relays

It is possible for each of the 5 backup customer codes to activate a different relay (or set of relays). After the change-relays password has been entered, the interface will beep once and wait for you to define which relay(s) should be activated when the first backup customer code is entered (see table on the next page). After you press the keys that define which relays will activate (press only one key at a time), press the 0 key to finalize your selections. The interface board will beep twice to indicate that it is waiting for you to define the relays associated with the second backup customer code. Repeat the process for all 5 backup customer codes.

Table 19. Output Relays

Key	Output Relay
1	1
2	2
3	3
4	4
5	5
6	6
7	1 pulse on Relay 1
8	2 pulses on Relay 1
9	3 pulses on Relay 1

Example to define relays as follows:

Code #	Relays
1	1
2	1 + 4
3	2
4	2 + 4 + 5
5	2 pulses on 1 + 3

[4][3][5][3][9][2][1][0] (Change-relays password)
 [1][0] (Relay definition for code # 1)
 [1][4][0] (Relay definition for code # 2)
 [2][0] (Relay definition for code # 3)
 [2][4][5][0] (Relay definition for code # 4)
 [8][3][0] (Relay definition for code # 5)

The default output relay programming is as follows:

Customer Code	Output Relays Activated
1	1
2	2
3	3
4	4
5	5

9 Troubleshooting

The following information is for technical service personnel, Unitec does not recommend end users repair their own equipment. However the following information may be useful in helping the end user to get his or her system up and running without requiring a service call from the local equipment distributor.

9.1 Printer Doesn't Print

Check the following functions:

1. Make sure the printer power light is ON. If not, plug printer in and turn power switch on.
2. Make sure the printer SEL (select) light is ON. If not, press the select button to turn it on.

If the SEL light is flashing, the most likely problem is that paper roll is either empty or not properly installed. The roll must be free to rotate. The sliding shaft that secures the roll should be beyond flush with the left edge of the printer.

3. Make sure printer cable is plugged into console & printer.
4. Make sure that a good ribbon is properly installed in the printer. Use only ribbons certified for dot matrix print heads, and replace ribbon before it begins to fray.

To test the printer, disconnect the printer cable from the console and perform the printer self test mode by turning the printer on while pressing the LF switch on the top of the printer. Release the LF switch after the self-test operation begins. The printer will print a test pattern and stop. If the test fails, have the printer repaired or replaced.

If the printer prints normally except for a missing horizontal section of each line it is likely a print head failure. Replace the print head or entire printer mechanism. If a new printer mechanism fails the self-test print check, it is likely a printer controller failure. Replace the printer controller board or repair or replace the printer.

If the printer passes the self-test print check, try printing a customer ticket making sure the "POWER" and "SEL" lights on the printer lid are both light. If the printer passes the self-test and fails to print during normal operations it is likely a POS4000 console main PC board failure. Replace the POS4000 console main PC board.

9.2 System Locked Up

Check the following function:

1. Make sure the console power light is ON. If not, plug console in and turn power switch on.

If you have problems, which you cannot resolve, a power reset may restore normal operation. Turn the power off for a minute and then back on. This will reset the console but will not affect the codes or counts in memory since the memory has a battery back-up.

9.3 Customer Buzzer Failure

If the buzzer on the interface board does not beep when customer keys are depressed first check the keypad by entering a code such as "123450". Verify your entry on the POS4000 main

console display. If no customer code is shown it is probably a keypad problem, therefore perform the customer keypad service tests. If the code entered appears on the console display, the customer buzzer is bad and you should replace the interface board.

9.4 Code Stacking Does Not Work

Stacking allows a second customer to be processed while a first customer is still in the carwash. In order for stacking to work properly, the wash in-use signal must turn on and remain on for the duration of the first customer's wash. The wash in-use LED on the interface board can be used to determine if the interface board is receiving the wash in-use signal

If a valid code is entered while a car is in the wash and this code does not activate the wash and is no longer valid check the car wash "In-use" as follows. When the car wash is in use, verify that the "Wash In-use" LED on the interface card is on. If the In-use signal turns off or flickers prior to the car leaving the car wash, stacked car wash activation signals are probably being sent to the car wash prior to finishing the previous wash. If this happens, the car wash will typically ignore that activation code.

Following is the sequence of events that should occur in a normal operation:

1. Car wash is empty and available for use
2. First customer enters valid code causing the Enter Wash relay to close
3. First customer drives into car wash
4. Wash in-use signal turns on causing Enter Wash relay to open
5. Second customer enters a valid code (wash in-use is still on) causing Code Accepted/Wait relay to close
6. If relay stacking is disabled then the function relays will close now
7. First customer leaves bay
8. Wash in-use turns off causing Code Accepted/Wait relay to open and Enter Wash relay to close
9. If relay stacking is enabled then the function relays will close now
10. Second customer drives into car wash
11. Wash in-use signal turns on causing Enter Wash relay to open
- 12.

**Note:**

Refer to the System Configuration Report to determine if relay stacking is enabled or disabled, and if your system allows Customer Stacking.

9.5 "Enter Wash" Signal Does Not Work

The "Enter Wash" feature produces a relay contact closure when any wash program is activated (either by a valid customer code or cash). This relay stays on until the wash "In-Use" signal turns on for that customer. In many circumstances, the "Enter Wash" signal for customer lights is

generated by the car wash equipment. If the carwash equipment generates the "Enter Wash" control signal, check the carwash equipment.

If the interface board "Enter Wash" signal is used, perform the "Enter Wash" relay test described in the Interface Test section. If the relay fails, replace the interface board.

**Note:**

The Enter Wash and Code Accepted/Wait relays are intended to control customer guidance lights. The status of the relays can be determined by the LEDs that are located on the board.

9.6 "Reenter Code" Signal Does Not Work

The "Reenter Code" signal should be activated for several seconds every time an incorrect code is entered at the car wash entrance. If this does not occur, use the "Reenter Code" relay test described in the Interface Test section. If this relay test fails, replace the interface board.

9.7 Bill, Coin or Audit Inputs Do Not Work

Audit counters are configured for either 24V AC/DC or 120V AC. To determine the voltage input setting, refer to the "POS4000 Interface Board Wiring Diagram" in the back of this manual. The input voltage jumper determines the acceptable input voltage range. The board will not work if the wrong voltage is applied and the board WILL BE DAMAGED if 120V is applied to an input jumpered for 24V board.

To test the audit inputs, put the interface board in the test mode and perform the audit input test as described in Section 3.2.2. If the audit test fails, replace the interface board.

9.8 Main Console Keys Do Not Work

If the console keys do not function properly, remove power from the main console for a short period. After power is returned to the main console, check key functions again. If one or two keys still do not function (no beep when pressed), replace membrane keypad or keyboard PC board. If a row or column of keys fails to function (no beep when pressed), check the keypad ribbon connection between the keypad PC board and main PC board inside the console (25 wire ribbon cable). If the ribbon connections and cable are OK, it is likely a main PC board failure. Replace main PC board in main console.

9.9 System Resets Each Time Power Is Turned On

The lithium battery used to maintain the console memory when the console is off probably needs replacement. Under normal usage this battery should last more than 5 years. Replace the main PC board battery backup RAM socket in the main console.

9.10 Main Console Is "DEAD"

Main console is plugged in but does not respond to main console keys or customer codes. If the main console power light is out check fuse in main console and if blown, replace. If the "power on" light is still out check the voltage from the wall transformer. The transformer supplies between 12 to 24VAC or DC depending on the transformer module. If the transformer is dead, replace it. If the transformer voltage and fuse are good, there is a problem in the main PC board. Repair or replace it.

Appendix A. Interfacing to an External Point-of-Sale

The POS4000 has the ability to communicate with External Point-of-Sale (EXTPOS) equipment. This standard feature for Version 2 POS4000s allows: 1) customers to purchase carwash codes at fuel pumps that have "pay at the pump" capabilities, and 2) cashiers to sell carwash codes via the cash register. If this feature is not present and you want to acquire it, you should contact your carwash sales representative to order a software upgrade.

The exact carwash capabilities of each external Point-of-Sale system vary by manufacturer, petroleum company, geographic location and current software version. You should consult your Point-of-Sale representative for questions about features of their equipment and how to use it.

Definition of Terms for External POS Connections

Site Controller:

On most Petroleum stores, there is one centralized device, which communicates and controls the pumps and card readers. In addition, this device may communicate or directly control the cash registers

Register:

This is the system the cashier uses to ring up petroleum or C-Store sales.

Carwash POS unit:

This is the console used to print up wash tickets and configure the Unitec Equipment. On a Generic POS4000 system, E-systems, or AutoTec it consists of the POS4000. On an Enterlink/V2, it consists of the Smart Terminal and the Junction box.

EXT POS Device:

The Unitec Carwash POS connects to this device in order to give it car wash codes when it requests them. This device depending upon the installation may be either a centralized site controller or register. Examples when connecting to a Gilbarco G-Site system the site controller is the EXT POS Device, when connecting to a Wayne Plus their Site controller is the EXT POS device. When connecting to a Panasonic one of their registers will be connected to and is designated as the EXT POS Device.

Baud Rate:

Speed of communications rate between Carwash POS Unit and EXT POS. Typical values used are: 2400, 9600 or 19200.

POS (feature) Offset:

This offset value is applied to the wash request from the EXT POS unit. For Example:

POS Offset value is 1 up

EXT POS unit requests a code for Wash 1 (Key 1 on POS4000)

The Unitec Carwash POS unit will shift the request by 1 in the positive (up) direction. Thus processing the request as for a Wash 2 (Key 2 on the POS4000)

POS Max Washes:

This is the maximum wash number that the Unitec Carwash POS Unit will respond to a code request. All requests above this value will be acted upon as if the POS Max Washes Value were subtracted from the Original request.

Example:

POS Max Washes is set to 3

Requests for washes 1,2, and 3 are unchanged (processed as 1,2 and 3 respectively)

Requests for washes 4, 5, and 6 are shifted down by 3 and are processed as 1, 2 and 3 (request for wash 4 processed as wash 1, request for wash 5 processed as wash 2, and request for wash 6 processed as wash 3)

This feature was added to adapt to the Chevron/Dresser-Wayne application. Note that POS Max Washes value is applied before the POS Offset. This feature is also used when configuring the Reverse order function (See Section 4.1.10.5)

External POS Type:

This is the Protocol type used to communicate from the Carwash POS unit to the EXT POS device. The proper POS Type must be used for each particular EXT POS device. Unitec's POS unit's Manuals will have an appendix with a chart showing the required POS type for each EXT POS device. This chart is also sent a part of a Unicam Upgrade for the POS4000 units. POS 1 and POS 2 are Ryko emulations and POS3 (also at times referred to the Unicam Protocol) is maintained by Unitec. POS0 is an obsolete Modem connection not used any more. Note that POS4000 consoles shipped without the Unicam option are configured for POS0 to be the default. Chips with POS0 as the default cannot be changed to POS 1, 2 or 3. E-System POS4000 consoles and Enterlinks come with Unicam option Standard (defaulted to POS2) and may be changed at any time.

If you use the GROUP keys of the POS4000 to sell carwashes, you have to set the POS Offset (see Section 4.1.10.1) of the POS4000. External POS types 1 and 2 (see below) request different carwashes as wash levels. In order to translate this wash level to the appropriate GROUP key, you must set the POS Offset direction as up and amount as the number of PROGRAM keys plus the number of OPTION keys. For example, if your POS4000 main console has 1 program key and 5 option keys you would set the POS Offset as 6 UP.

If you leave the POS Offset at the default value (0 DOWN), then wash level 1 will translate to the first POS4000 cashier key (program 1), wash level 2 will translate to the second cashier key (program 2 if present or option 1), etc. If your POS4000 main console supports as many program keys as the external POS system has wash levels, then you typically will NOT need to set the POS Offset.

The "Define EXT. POS Type" command (see Section 4.1.10.2) is used to select the type of external POS equipment that the POS4000 can communicate with. At the current time (new manufacturers are being added), the POS4000 can connect with the following external POS systems:

- Gilbarco G-Site (C2, and CPU)
- Dresser-Wayne Wayne Plus
- Schlumberger Micromax Pro I, and II
- Allied Site controller (Uses Schlumberger Micromax)

- Management Solutions
- Autogas
- Canmax/EDS
- Gasboy
- Panasonic
- Softsense
- Suntronics
- Tokiem
- Verifone

External POS Type	External POS Manufacturer	Serial Interface	Site Controller or Register Default BAUD Rate
0	none	none	none
1	Wayne Dresser	POS1	19200*
2	Gilbarco Panasonic Suntronic (see note) Verifone (Ruby) Allied	POS2	19200* 9600 2400 (see note) 9600 9600*
3	Softsense Tokiem Management Solutions, Inc. Autogas Canmax Schlumberger NDC~ Gas Boy Bennet	Uni-CAM (POS 3)	2400 2400 9600 Varies Varies Varies Varies 2400 Varies

* Baud rate on Site Controller fixed at specified baud rate.

The SYSTEM CONFIGURATION REPORT contains a section that documents the current configuration of the serial interface used to communicate with external POS equipment. The SYSTEM CONFIGURATION REPORT also contains a section that documents the current BAUD rate. The BAUD rate of the POS4000 main console and external POS system MUST be identical. To change the BAUD rate of the POS4000 main console refer to Section 4.1.6.



Note:

With the Optional Remote ExtPOS Connection Software, each POS4000 console's BAUD rate must be identical to the external POS system it is connected to.

 **Note:** When using the Suntronic model SM-960, you MUST set the maximum code length as 5 (see section 6.2.4). The SM-2000 allows you to use 5 or 6 digit codes.

As communication occurs between the POS4000 main console and an external POS system, the second line of the POS4000 main console display will show the most recently processed message. If any communication errors occur, error messages will be displayed. While these messages mean very little to the operator, they can provide important information to Unitec technical support. If you suspect there is a communication problem, it will be very useful if the operator watches the second line of the display and notes any activity prior to contacting Unitec technical support.

Codes generated for external POS type 1 limited to 5 digits in length (4 significant digits plus a 0). There are approximately 6500 possible 5-digit codes. If the valid codes database is allowed to fill to the maximum of 5000 codes, it will increase the time required to generate a new code. This increase in time may result in a communication error between the POS4000 main console and the external POS equipment. This communication error results in either no code or an invalid code being printed on the customer's receipt.

To prevent this, you can do one of two things. 1) Set the maximum code length of all codes to 5 (see Section 4.1.4). This will decrease the VALID codes database to 3000 and should therefore prevent the problem, or 2) Periodically delete USED CODES and/or OLD VALID CODES from memory by using the "Clear All Used" (see Section 4.11.4) and "Clear OLD Codes" (see Section 4.11.5) commands. This should be done often enough to keep fewer than 3500 valid codes in memory. How many carwash codes are generated and how soon they are used will determine how frequently old codes should be deleted. WIRING INFORMATION:

SIGNAL NAME	PIN for 6.1 hardware	PIN for 6.2 and higher hardware
Data INPUT	4	2
Data OUTPUT	3	3
SIGNAL GND	1	5

To distinguish 6.1 from 6.2 hardware, look at the label attached to the base of the unit. If the MODEL field has "POS4000", then it is 6.1 hardware; if it has "POS4000/2" (or /3 etc.) then it is 6.2 or higher hardware. Note that the 6.2 and higher pin outs are standard for a 9-pin DTE serial port.

If you have a console with version 6.1 hardware do not change the wiring of the cable, but acquire an SA1606 adaptor to make the 6.1 console conforms to the latest pin outs. These adaptors are available to Wash distributors Via Wash manufacturers or Directly from Unitec.

 **Note:** Optional Software is available for EXTPOS Connection at Secondary POS4000 Consoles.

Troubleshooting Guide

Symptom: Wash 1 at the pump is configured to be the most expensive wash and gives a code for the cheapest wash.

Cause: EXT POS is configured for the reverse order as configured in the POS4000.

Solution: Set Reverse order configuration and POS Max Washes (See Sections 4.1.10.5 and 4.1.10.3)

Symptom: Receipt at pump or register is showing that code is good for that day only. Code age warning is set to another number

Cause: EXT POS is using enhanced protocol commands

Solution: Enable "Set Send Code Age" function (See Section 4.1.10.4)

Symptom: Codes on ticket do not have 0 at end

Cause: Some manufacturers of Register Equipment only work with 5 digit codes

Solution: Set the code length to 5 digits

Symptom: Message "A timeout from unit 2" appears on screen of console when the site controller is connected to the DB-9 connector of the console

Cause: Most all register/site controller equipment is Earth grounded at the Signal end. This may cause ground differentials when connected to Older POS4000 consoles.

Solution: You may want to purchase a POS4000 Update kit, which will include an isolation transformer for the interface board and grounding instructions.

Symptom: Message "A POS No STX XXX", "A POS no SOH" or "A POS BCC Error" appears on second line of console screen

Cause: The serial port of the console is receiving incorrect data from the Site Controller/Register. You may have the wrong POS type selected from the AEXT POS MENU-> refer to the chart in this appendix.

The Serial Baud rate may also not correspond to the BAUD rate on the Ext POS Device.

Solution: Change the POS type or Baud rate to the correct one. Remember; when you change the Baud Rate you must power down the POS4000 then power it back up after making the serial baud change.

Symptom: Some of the washes work but the codes (as checked using the check code key) are not the correct wash type.

Cause: The POS Offset value may need to be adjusted or the POS MAX WASHES value is set incorrectly.

Solution: Review the above procedure concerning the POS offset. The POS MAX WASHES value is typically set to 0 (feature disabled). This value is only used on Chevron sites when connected to a Dresser/Wayne Wayne +

Symptom: Cashier ticket does not print out a code

Cause: You may have a version of the console that has 6.1 hardware and requires an adapter for the Cab

You may also have a Hardware or Cable problem.

Solution: Verify if the main board hardware is Version 6.1 or not. If so acquire an SA1606 adapter from Unitec.

To diagnose a Hardware problem, Unitec Provides a Windows based software package for Wash manufacturers and Distributors to test the Communications port when connected to a PC laptop computer. This package is called "POSTEST" and is available at a small cost to Field technicians.

Appendix B. Multiple Unit Configuration



Note: The terms unit number and address are interchangeable.

The POS4000 system is capable of controlling multiple customer interfaces (carwashes or bays) and multiple points-of-sale (POS4000 consoles). This is a Standard feature for Version 2 units. If this feature is not present and you want to acquire it, you should contact your carwash sales representative to order a software upgrade. The same version of software must be used on each console you have on the same system. In addition, the software in the Entry systems must also be of the same version if you are using entry systems with the Unitec POS4000 interface board. If you are using multiple Hamilton Autotecs please contact Hamilton MFG for any questions on compatibility.

Each console and customer interface board is connected to the 2-wire communication network and is assigned a unique unit number or address. A single POS4000 controller (main) console must act as the network controller. Additional POS4000 consoles may be connected to the network to provide additional points-of-sale, these are referred to as remote consoles.

A controller console must have an address of 1. Customer interfaces must begin at address 2 and continue sequentially. The addresses of remote consoles must begin after customer interfaces and continue sequentially. The unit number of a customer interface is determined by DIP switches located on the customer interface board (refer to the layout drawing in the back of this manual for position and setting of switches). The unit number of a POS4000 is set by using the "Set Unit Number" command (see Section 4.1.11.1). Unit numbers for Hamilton Autotec Coin boxes are determined by a wire harness change in the Hamilton coin box. Contact Hamilton MFG for a reference to this harness change.

Upon changing bay configurations, any prior accounting reports should be printed out first. Adding a Wash Select II, for instance, or changing the bay number of the remote console could cause you to lose the accounting information associated with the remote console.

Unit numbering examples:

- A system with 1 POS4000 and 2 customer interfaces (2 carwash bays):
 - 1 controller console with address 1.
 - 2 customer interfaces with addresses 2 and 3.

In this example the console is set up to have 2 bays and 0 remote consoles

- A system with 2 POS4000s (One Controller and 1 remote) and 1 customer interface (1 carwash bay):
 - 1 controller console with address 1.
 - 1 customer interfaces with address 2.
 - 1 remote consoles with addresses 3.

In this example, the controller console is set up as the controller at address 1, to have 1 bay and 1 remote console. The remote console is set up to be a remote, address 3, 1 bay and 0 remote consoles.

In addition to controlling the communication network, the network controller generates all customer codes (including ones printed at remote consoles) and maintains the database of valid

and used codes. Only accounting information from the Controller console is valid. Any accounting information, or code database information on the remote console is invalid.

NOTES:

1. The following commands are NOT available on Remote consoles:

MEMORY INFORMATION

FLEET ACCOUNTS

SET PRICING

CLEAR AUDIT COUNTS

All other commands are available at the remote consoles.

With standard software, EXT POS connection is only possible with the Controller console. EXT POS connection is not functional from a Remote Console.

With the Optional Remote Extpos Connection Software, EXT POS connection is possible with any console (Controller or Remote console). Each console can be configured to interface to a different EXT POS. If a remote console is connected to an EXT POS that requires the code length to be 5 digits, then the code length MUST be changed to 5 on the Controller console, which will automatically change the code length for all the consoles.

2. When the following commands are executed at a controller console which has 1 or more remote consoles connected to it, the related information will be automatically downloaded to all remote consoles:

SYS SETUP - Set Time, Set Code Age Warning, Disable Cashier Key, Code Length

SET PRICE - Set any price level, Set Tax Rate, Set Tax Round Off

SETUP FEATURE - Change Wash Name

If a remote console is off-line while these items are programmed at the controller console, this information will NOT be downloaded. If this happens, the "Program Remote Consoles" command (see Section 4.1.11.4) can be used to download all parameters to all remote consoles. Executing this command causes the Controller to download the following information to all remote consoles: Prices, Wash Labels, System time, Code age warning, Disabled cashier keys, Tax rate and Tax round off status, and Code Length.

3. When connecting additional units to the communication network, you should simply daisy chain from one unit to the next. Pin 1 of all units should be connected to the same conductor, (RED) and all pin 2's should be connected to the same conductor (WHITE). The order in which units are physically added to the network is not significant. Power should be OFF at all units while making wiring changes.

The shield of the communication cable should also be daisy-chained at each unit. However, the shield should only be connected to an EARTH GROUND at 1 end of the cable. For systems with Unitec POS4000 interface boards the Shield should be connected to Pin 4 of one of the interface boards only and should not be directly connected to any other interface board, Console, or Earth ground point.

Recommended procedure for configuration of consoles and bays:

1. Determine the addresses to configure any remote bays or consoles.
2. Power on the main console with the Green communications plug disconnected.
3. Configure the main console as unit 1.
4. Configure the main console as Controller.
5. Configure the Number of Bays and Consoles for the main controller.
6. Leave main console unplugged from the communications cable. **Turn off power.**
7. If you are using multiple bays, configure their addresses (unit numbers). Reference POS4000 Interface board wiring diagram in this manual.
8. If you are installing a remote console, continue otherwise skip to step 15.
9. Power on remote console with communications cable unplugged.
10. Configure remote console unit number. Remember the first remote console is unit number 3 in a single carwash scenario, and unit 4 in a two bay carwash etc).
11. Configure the remote console as remote.
12. Configure the number of bays and remote consoles (remember the number of remote consoles as programmed into a remote console is always 0).
13. Turn Remote console off.
14. If you have any more remote consoles perform steps 9-13 on each other remote console.
15. Power up all entry systems.
16. Power up all remote consoles and connect Communications cable.
17. Power up controller (master) console and connect communications cable.
18. Configure the Prices, wash names, code length etc on controller console if not done so already.
19. Configure the messages for the remote console if you have one.
20. Configure each console linked to an EXT POS.
21. If you are using remote consoles, perform a "Program remote Consoles" command; this will assure the downloading of important information to any remote console. (See Section 4.1.11.4)
22. Verify that you can print codes from the remote console and that the ticket Header and footer messages are correct. Also verify prices on ticket are correct.
23. Verify codes are accepted at all carwash bays.

Appendix C. Reconciliation of Sales When Connected to an EXTPOS Device

EXT POS device: (External Point of Sale device) is defined as the computer system connecting to the EXT POS connection of the Carwash POS device (Enterlink, POS4000). This EXT POS device may be a Site controller (system controlling pumps) or Register.

By connecting your carwash Point of Sale device (POS4000 or Enterlink) to an external POS device, you can significantly increase your car wash sales via Pump sales. In the implementation of this, nearly all of the devices that may connect to the EXT POS connection have not allowed the conveyance of the price and discount information to the carwash POS equipment. Therefore, the Net Register and EXT POS Sales on the Carwash POS equipment accounting reports will be in discrepancy with the Register totals or Back room reports from the EXT POS device. The following is a method of taking the reports and totalize the car wash sales.

Reports from the Register:

All manufacturers of Register equipment provide reporting of Car wash sales via a report system. You should find a report that details both Register Totals and Pump totals. The totals on this report should be reset at the same time you reset the totals on your Carwash POS.

Take this value and this is you're: Correct EXT POS Totals.

Reports from the Unitec Carwash POS:

Sample Totals section of report:

	MANAGER	SHIFT
REGISTER SUMMARY		
Console Sales	\$ 200.00	\$ 12.00
EXT POS Sales	\$ 6,175.00	\$ 220.00
Sales Refunds-	\$ 12.00	\$ 3.00
Net Register	\$ 6,363.00	\$ 229.00

COIN BOX SUMMARY

Cash Deposited	\$ 650.00	\$ 23.00
Cash Dispensed	\$ 10.00	\$ 2.00
Overpayments	\$ 1.75	\$.25
Net Cash	\$ 641.75	\$ 21.25

The Unitec POS system shows the following information on the accounting reports:

Register Summary:

This Summary report's sales totals by the Unitec console or codes given out via communications link to EXT POS Device (Site controller or register) including sales at the pump via this link. Note: due to the implementation by Site controller and register manufacturers, EXT POS sales reported by Carwash POS systems are incorrect as stated in the Preface. The Total Console sales minus any refunds (voided codes) is given as follows:

Net Console = Console Sales - Sales Refunds

Entry System Summary:

This summary gives a report on the amount of cash entered directly into the entry system at the carwash. This report will only appear if there is cash acceptance at the coin box. The report may be slightly different for your system depending if your system uses an Enterlink, AutoTec, E-systems or a Standard Unitec interface board. Total cash sales are shown as Net cash. If Net cash is not shown then the Net cash is Cash Deposited. Net cash will show for Enterlinks, AutoTecs and E-system coin boxes only.

Correct method of calculating sales:

Add the following numbers to derive the total sales:

Correct Ext. POS Sales (from Site controller/Register report)

Net Console Sales (from formula above)

Net Cash Sales (as described above)

Appendix D. Changing the Wash Description Insert Pocket on Version 2 Style Cases

Preface:

The POS4000 Version 2 style case is designed with a durable membrane keypad with insert pocket that can be customized to your specific discounts and wash names. The POS4000 comes with a standard generic card loaded into your console keypad. Although any sheet of paper that is 3.7" wide and 3.6" tall may fit into the pocket, Unitec has provided your unit with 2 sheets that are laser printable with 4 cards on each that may be cut out and used upon installation.

Replacing or changing Insert pocket card:

1. Remove the 4 screws holding the cover to the metal chassis. Two are located in the rear and two are located on the bottom front.
2. Fold the top cover forward exposing the bottom side of the plastic cover.
3. The original insert pocket card will be sticking out of a 3.75" slot in the center of the cover.
4. Remove the insert pocket card and place the new card that you have customized into the slot. Verify the placement of the card by viewing the front of the keypad before you continue. You may wish to use a piece of clear tape to hold the insert pocket from moving over time.
5. Replace the cover and secure the 2 screws in the bottom front first.
6. Install but do not tighten the rear screws through the slotted holes in the rear of the cover.
7. While pushing down on the top of the keypad, tighten the rear two cover screws.

Appendix E. Application Notes for Using Default Discounts Function

The following application note covers the use of the Default Discounts function for the purpose of correctly accounting for carwashes from within the POS4000 system.

Requirements:

EXT POS device (register/site controller) must be able to the following:

- Allow the ability to decide if each wash is to be sold at pump or register only
- Allow the configuration of 6 or more discrete wash types (depending on the discount levels you need to implement the register may have to accommodate up to 12 wash types)

POS4000 requires Software Version 7.11 or later

POS4000 must have serial interface set to 1 or 2 (POS1 or POS2)

POS4000 must have POSMAX washes value set to the number of REAL carwashes

POS4000 must have reverse order enabled if first EXTPOS wash is the most expensive wash

The following example is for a Wayne + system with Chevron software configuration:

Carwash has 3 real washes.

Wayne carwashes start with the most expensive wash first.

Wayne must be programmed with 9 washes

Wayne washes are to be programmed as follows

(Note: washes 1 and 2 not used. Wayne wash 3 requests Unitec wash 1)

Wash Number	Reg Price	Reg PLU	w/ Gas Price	w/Gas PLU
3	\$7.00	48(not used)	\$5.00	51(at pumps)
4	\$6.00	49(not used)	\$4.00	52(at pumps)
5	\$5.00	50(not used)	\$3.00	53(at pumps)
6	\$5.00	54(c-store w/gas)	n/a	n/a
7	\$4.00	55(c-store w/gas)	n/a	n/a
8	\$3.00	56(c-store w/gas)	n/a	n/a
9	\$7.00	57(c-store reg \$)	n/a	n/a
10	\$6.00	58(c-store reg \$)	n/a	n/a
11	\$5.00	59(c-store reg \$)	n/a	n/a



Note:

Wayne + can be configured with different PLU numbers depending on Oil company version.

When a customer comes into the C-store and purchases a wash without buying gas, the Cashier should use PLUs 57, 58 and 59 instead of 48, 49, and 50. PLUs 48, 49, and 50 should not be used by the cashier ever! If they are used, the accounting will be in discrepancy. C-store purchases of carwashes w/ gas must use PLUs 54, 55 and 56.

If a customer is given a refund for a code, a code void must always be done at the POS4000 even if the sale was voided in the Wayne +

POS4000 pricing report should look as follows:

Feature *	Price Level		
	Full	Disc1	Disc2
Express Wash	5.00	3.00	0.00
Deluxe Wash	6.00	4.00	0.00
Super Wash	7.00	5.00	0.00
Works Wash	0.00	0.00	0.00
Program 5	0.00	0.00	0.00
Program 6	0.00	0.00	0.00
Program 7	0.00	0.00	0.00
Program 8	0.00	0.00	0.00

*Your wash names may differ.

Prices must be in ascending order (cheapest wash is first).

After configuring EXTPOS menu the final print out should look as follows:

Serial Interface = POS1

POS Feature offset = 0 DOWN

POS Max Washes = 3

Send Code Age: Disabled

Reverse order: Enabled

EXT Wash Requested	Default Disc Level	Feature Returned	Name*
1	1	P3	Super Wash
2	1	P2	Deluxe Wash
3	1	P1	Express Wash
4	1	P3	Super Wash
5	1	P2	Deluxe Wash
6	1	P1	Express Wash
7	0	P3	Super Wash
8	0	P2	Deluxe Wash
9	0	P1	Express Wash
10	0	P3	Super Wash
11	0	P2	Deluxe Wash
12	0	P1	Express Wash

*Your Wash Names may differ.

 **Note:** Even though Wayne programs washes 3-11, the Wayne internally re-maps them to washes 1-9 before requesting them from the POS4000.

Appendix F. Application Notes for Using the Reverse Order Function

Purpose:

To program a POS4000 system where the Register/Pumps are to be programmed with wash 1 as the most expensive.

Requirements:

POS4000 must be loaded with Software version 7.10 or higher. POS4000 system must be set up with wash 1 as the least expensive in order to allow proper cash purchases at the entry system under all circumstances.

Setup:

This example shows how to configure a 3 wash system at the register/pumps and at the POS4000. The setting of a 4 wash system is similar to this example.

The following is an example setup:

Acquire version 7.10 or later software for the POS4000 and install into POS4000.

Program the wash prices as follows:

Program key	Regular price	Discount 1 price
1	\$4.00	\$2.00
2	\$5.00	\$3.00
3	\$6.00	\$4.00

Discount 2 prices may be programmed as per your requirements.

If you are using group keys (tunnel wash) then use groups 1, 2, and 3, then assign program and option keys to those groups as per POS4000 manual.

Modify the wash names as required. You may have to alter the price signage at the buttons of a Hamilton coin box if your wash name assignments have changed.

Modify the wire connections from the coin box if the POS4000 wash assignments have changed.

From the **Ext POS menu->** of the **System setup menu** change set the following:

POS Type = 1 for Dresser Wayne, 2 for Gilbarco or Verifone. See POS4000 manual for other Register types. Serial Baud rate may also have to change for other manufacturers. Compare your system configuration report to the Register Baud rate settings
POS Offset = 0 down (default) (this will be different if you are using group keys)
POS Max Washes = 3 (set to 4 if using 4 washes)
Send Code Age: Disabled (this is enabled if Receipt at pump shows an expiration date of code)
Reverse order: Enabled

After the **last** change is made, a printout should follow that looks like this. (Note if using groups Feature returned will be G1, G2 etc).

Serial Interface = POS 2 (this may be different)

POS Feature offset = 0 down

POS Max Washes = 3 (or 4 if using 4 washes)

Send Code Age: Disabled

Reverse order: Enabled

EXT Wash Requested	Default Disc Level	Feature Returned	Name
1	0	P3	Super Wash
2	0	P2	Deluxe Wash
3	0	P1	Express Wash
4	0	P3	Super Wash
5	0	P2	Deluxe Wash
6	0	P1	Express Wash
7	0	P3	Super Wash
8	0	P2	Deluxe Wash
9	0	P1	Express Wash
10	0	P3	Super Wash
11	0	P2	Deluxe Wash
12	0	P1	Express Wash

This will allow 3 washes to be sold at the pumps (\$6, \$5, and \$4).

To test this system:

- Get a code from each of the 3 possible wash types from the pumps then do a code check on each verifying the wash names match.
- Get a code for each of the 3 possible wash types at each possible discount from the Register then do a code check on each verifying the wash names match. This verifies the EXTPOS connection is configure properly
- Print a code at the regular price for each of the 3 wash types from the POS4000 then use the washes at the entry system. This verifies the wash wiring to the Mark VII was done properly.
- Pay for each of the 3 washes at the entry system using cash and verify the proper wash type was given. This verifies that the Buttons on the Autotec are configured properly.